

GIORIK

INNOVATIVE COOKING EQUIPMENT SINCE 1963



LISTINO COTTURA MODULARE

MODULAR COOKING LINE PRICE LIST | MODUL KOCHLINIE PREISLISTE
TARIF LIGNE DE CUISSON MODULAIRE | LISTA DE PRECIOS LÍNEA DE COCCIÓN

PPC

PRODOTTI PRONTA CONSEGNA

I prodotti contrassegnati con **PPC** sono disponibili alla spedizione in meno di 24h.

Products marked with **PPC** are available for shipment in less than 24 hours.

Mit **PPC** gekennzeichnete Produkte sind in weniger als 24 Stunden versandbereit.

Les produits marqués avec **PPC** sont disponibles pour l'expédition en moins de 24 heures.

Los productos marcados con **PPC** están disponibles para su envío en menos de 24 horas.

unika700



CPG726

CUOCIPASTA A GAS
GAS PASTA COOKER
GAS NUDELKOCHER
CUISSIÈURS À PÂTE À GAZ
CUECE-PASTAS GAS



CPE726

CUOCIPASTA ELETTRICO
ELECTRIC PASTA COOKER
ELEKTRO NUDELKOCHER
CUISSIÈURS À PÂTE ÉLECTRIQUES
CUECE-PASTAS ELÉTRICOS



CG740G

CUCINE GAS
GAS RANGES
GASHERDE
FORNEAUX GAZ
COCINA A GAS



ECG740G

CUCINE GAS
GAS RANGES
GASHERDE
FORNEAUX GAZ
COCINA A GAS



FG7117T

FRIGGITRICI GAS 17LT
GAS DEEP FAT FRYERS 17LT
GAS FRITEUSEN 17LT
FRITEUSES GAZ 17LT
FREIDORA A GAS 17LT



FG7217T

FRIGGITRICI GAS 17+17LT
GAS DEEP FAT FRYERS 17+17LT
GAS FRITEUSEN 17+17LT
FRITEUSES GAZ 17+17LT
FREIDORA A GAS 17+17LT



FG7215T

FRIGGITRICI GAS 13+13LT
GAS DEEP FAT FRYERS 13+13LT
GAS FRITEUSEN 13+13LT
FRITEUSES GAZ 13+13LT
FREIDORA A GAS 13+13LT

unika900



CPG926

CUOCIPASTA A GAS
GAS PASTA COOKER
GAS NUDELKOCHER
CUISSIÈURS À PÂTE À GAZ
CUECE-PASTAS GAS



CPE926

CUOCIPASTA ELETTRICO
ELECTRIC PASTA COOKER
ELEKTRO NUDELKOCHER
CUISSIÈURS À PÂTE ÉLECTRIQUES
CUECE-PASTAS ELÉTRICOS



CG940G

CUCINE GAS
GAS RANGES
GASHERDE
FORNEAUX GAZ
COCINA A GAS



CG960G

CUCINE GAS
GAS RANGES
GASHERDE
FORNEAUX GAZ
COCINA A GAS



FG9117T

FRIGGITRICI GAS 17LT
GAS DEEP FAT FRYERS 17LT
GAS FRITEUSEN 17LT
FRITEUSES GAZ 17LT
FREIDORA A GAS 17LT

PASTICCERIA



PFE1813

FRIGGITRICI DA TAVOLO
COUNTER FRYERS
TISCHFRITEUSEN
FRITEUSES POSABLES
FREIDORAS DE MESA



PFE1814

FRIGGITRICI DA TAVOLO
COUNTER FRYERS
TISCHFRITEUSEN
FRITEUSES POSABLES
FREIDORAS DE MESA



MFG1800

FRIGGITRICI A GAS DA TAVOLO
COUNTER GAS FRYERS
TISCHGASFRITEUSEN
FRITEUSES À GAZ POSABLES
FREIDORAS A GAS DE MESA

Le apparecchiature a gas sono predisposte per gas metano (G20-20mbr; con ugelli per il cambio in GPL). • The gas appliances are prepared for natural gas (G20-20mbr, also contains nozzles for the change in GPL). • Die Gasgeräte sind für Erdgas vorbereitet (G20-20 mbar, enthält auch Düsen für den Wechsel in GPL). • Les appareils à gaz sont préparés pour le gaz naturel (G20-20 mbar, contient également des buses pour le changement de GPL). • Los aparatos de gas están preparados para gas natural (G20-20 mbar, también contiene boquillas para el cambio en GPL).

I dati del presente documento sono da ritenersi non vincolanti. Modifiche ai prodotti possono essere apportate senza preavviso dal costruttore • The manufacturer reserves the right to modify any product without prior notice • Die Daten dieser Beschreibung sind nicht als bindend anzusehen. Der Hersteller Kann ohne Vorankündigung Änderungen an den Produkten vornehmen • Des modifications aux produits peuvent être apportées sans préavis du constructeur • La casa se reserva el derecho de aportar a los aparatos las modificaciones que creera oportuno.

INDICE

INDEX • INHALT • SOMMAIRE • ÍNDICE

gio60	PIANI COTTURA COOKING TOPS • KOCHPLATTEN PLAQUES DE CUISSON • PLANOS DE COCCIÓN.....	18
	FRY TOP GRIDDLE • GRILLPLATTEN • GRILLS • FRY-TOP.....	20
	FRY TOP • GRIGLIE A PIETRA LAVICA GRIDDLE - LAVASTONE GRILLS • GRILLPLATTEN - LAVASTEINGRILLS GRILLS - GRILLS À PIERRE DE LAVE • FRY-TOP - PARILLAS CON PIEDRA VOLCÁNICA.....	22
	CUOCIPASTA PASTA COOKER • NUDELKOCHER CUISEURS À PÂTE • CUECE-PASTAS.....	23
	FRIGGITRICI DA TAVOLO • SCALDAPATATE COUNTER FRYERS • TISCHFRITEUSEN • FRITEUSES POSABLES • FREIDORAS DE MESA CHIPS SCUTTLES • POMMES FRITES-WÄRMER • BAC DE SALAGE • CALIENTAPATATAS.....	24
	LAVELLO • MODULI NEUTRI • BAGNO MARIA WASH BASIN - NEUTRAL UNITS - BAIN-MARIE • SPÜHLBECKEN - NEUTRALE ELEMENTE - WASSERBAD ÉVIER - ÉLÉMENTS NEUTRES - BAIN MARIE • PILA - MÓDULOS NEUTROS - BAÑO MARÍA.....	25
	CUOCIPASTA ELETTRICI ELECTRIC PASTA COOKER • ELEKTRO NUDELKOCHER CUISEURS À PÂTE ÉLECTRIQUES • CUECE-PASTAS ELÉCTRICOS.....	25
	ACCESSORI ACCESSORIES • ZUBEHÖR • ACCESSOIRES • ACCESORIOS.....	26
LineaBase 700	CUCINE A GAS A GIORNO E SU FORNO PPC GAS RANGES WITH AND WITHOUT OVEN • GASHERDE MIT UND OHNE BACKOFEN FORNEAUX GAZ SANS ET AVEC FOUR • COCINAS A GAS.....	30
unika700	CUCINE A GAS A GIORNO E SU FORNO PPC GAS RANGES WITH AND WITHOUT OVEN • GASHERDE MIT UND OHNE BACKOFEN FORNEAUX GAZ SANS ET AVEC FOUR • COCINAS A GAS.....	31
LineaBase700	CONFIGURAZIONE BRUCIATORI CONFIGURATION BURNERS • KONFIGURATION BRENNER CONFIGURATION BRÛLEURS • CONFIGURACION DE QUEMADORES.....	32
unika700	CONFIGURAZIONE BRUCIATORI CONFIGURATION BURNERS • KONFIGURATION BRENNER CONFIGURATION BRÛLEURS • CONFIGURACION DE QUEMADORES.....	32
	CUCINE A GAS SU FORNO CON TUTTAPIASTRA GAS RANGES WITH OVEN AND SOLID TOPS • GASHERDE MIT BACKOFEN UND GLÜHPLATTENHERDE FORNEAUX GAZ AVEC FOUR ET COUP DE FEU • COCINAS A GAS CON HORNO Y PLACAS RADIANTES.....	33
	CUCINE A GAS CON TUTTAPIASTRA GAS RANGES WITH SOLID TOPS • GASHERDE MIT GLÜHPLATTENHERDE FORNEAUX GAZ AVEC COUP DE FEU • COCINAS A GAS CON PLACAS RADIANTES.....	34
	CUCINE TUTTAPIASTRA SOLID TOPS • GLÜHPLATTENHERDE CUISEUR COUP DE FEU • PLACAS RADIANTES.....	35

INDICE

INDEX • INHALT • SOMMAIRE • ÍNDICE

ACCESSORI

ACCESSORIES • ZUBEHÖR • ACCESSOIRES • ACCESORIOS 35

CUCINA ELETTRICA PIASTRE QUADRE

ELECTRIC RANGE WITH SQUARE PLATES • ELEKTROHERDE MIT VIERECKIGEN GUSSPLATTEN
FORNEAUX ÉLECTRIQUES AVEC PLAQUES CARRÉES • COCINAS ELÉCTRICAS CON PLANCHAS CUADRADAS 36

CUCINE ELETTRICHE CON PIASTRE ROTONDE

ELECTRIC RANGE WITH ROUND PLATES • ELEKTROHERDE MIT RUNDEN PLATTEN
FORNEAUX ÉLECTRIQUES AVEC PLAQUES ARRONDIES • COCINAS ELÉCTRICAS CON PLANCHAS REDONDAS 37

CUCINE VETROCERAMICA

RANGES CERAMIC GLASS • HERDE GLASKERAMIK
PLAQUES DE CUISSON EN VITROCÉRAMIQUE • COCINAS VETROCERAMICA 38

CUCINA A INDUZIONE

INDUCTION RANGES • INDUKTIONSHERDE
PLAQUES DE CUISSON À INDUCTION • COCINAS ELECTRICAS A INDUCCIÓN 39

ACCESSORI

ACCESSORIES • ZUBEHÖR • ACCESSOIRES • ACCESORIOS 39

BRASIERE MULTIUSO

MULTI COOKING BRATT PANS • ELEKTRO MULTI-BRÄTER • MULTI-SAUTEUSE • SARTEN MULTIPLO 40

SCALDAPATATE

CHIPS SCUTTLES • POMMES FRITES-WÄRMER • BAC DE SALAGE • CALIENTAPATATAS 40

FRY TOP A GAS

GAS GRIDDLE PLATES • GAS-GRILLPLATTEN • GRILLADES GAZ • FRY-TOP A GAS 41

FRY TOP ELETTRICI

ELECTRIC GRIDDLE PLATES • ELEKTRO-GRILLPLATTEN • GRILLADES ÉLECTRIQUES • FRY-TOP ELÉCTRICOS 42

AQUA-GRILL A GAS

GAS STEAMGRILL • DAMPF GRILL, GAS AUSFÜHRUNG • GRILLE VAPEUR À GAZ
VAPOR BARBACOA DE GAS 43

AQUA-GRILL ELETTRICI

ELECTRIC STEAMGRILL • DAMPF GRILL, ELEKTRO AUSFÜHRUNG • GRILLE VAPEUR ÉLECTRIQUE
VAPOR BARBACOA ELÉCTRICO 43

GRIGLIE A PIETRA LAVICA

LAVA ROCK GRILLS • LAVASTEINGRILLS • GRILLES À PIERRE VOLCANIQUE • BARBACOA DE PIEDRA LÁVICA 44

ACCESSORI

ACCESSORIES • ZUBEHÖR • ACCESSOIRES • ACCESORIOS 44

BAGNO MARIA

BAIN MARIES • BAIN-MARIES • BAIN-MARIE • BAÑO MARÍA 45

ACCESSORI

ACCESSORIES • ZUBEHÖR • ACCESSOIRES • ACCESORIOS 45

ACCESSORI PER CUCINE

ACCESSORIES FOR RANGES • ZUBEHÖR FÜR HERDE
ACCESSOIRES POUR FORNEAUX • ACCESORIOS PARA COCINA 46

INDICE

INDEX • INHALT • SOMMAIRE • ÍNDICE

	ACCESSORI PER FRY TOP ACCESSORIES FOR FRY TOP • ZUBEHÖR FÜR GRILLPLATTEN ACCESSOIRES POUR GRILLADES • ACCESORIOS PARA FRY-TOP	47
	CUOCIPASTA GAS ED ELETTRICI PPC GAS AND ELECTRIC PASTA COOKER • ELEKTRO UND GAS NUDELKOCHER CUISEIERS À PÂTE À GAZ ET ÉLECTRIQUES • CUECE-PASTAS GAS Y ELÉCTRICOS	48
	ACCESSORI PER CUOCIPASTA ACCESSORIES FOR PASTA BOILERS • NUDELKOCHERZUBEHÖR ACCESSOIRES POUR CUISEUR À PÂTES • ACCESORIOS PARA CUECE-PASTAS	49
	FRIGGITRICI GAS PPC GAS DEEP FAT FRYERS • GAS FRITEUSEN • FRITEUSES GAZ • FREIDORAS A GAS	50
	FRIGGITRICI ELETTRICHE ELECTRIC DEEP FAT FRYERS • ELEKTRO FRITEUSEN FRITEUSES ÉLECTRIQUES • FREIDORAS ELÉCTRICAS	52
	ACCESSORI PER FRIGGITRICI ACCESSORIES FOR FRYERS • ZUBEHÖR FÜR FRITEUSEN ACCESSOIRES POUR FRITEUSES • ACCESORIOS PARA FREIDORAS	53
	BRASIERE ROVESCIBILI TILTING BRATT PANS • KIPPBRATPFANNEN SAUTEUSES BASCULANTES • SARTENES BASCULANTES	54
	PENTOLE BOILING PANS • KOCHKESSEL • MARMITES • MARMITAS	55
	ACCESSORI PER PENTOLE ACCESSORIES FOR BOILING PANS • KOCHKESSELZUBEHÖR ACCESSOIRES POUR MARMITES • ACCESORIOS PARA MARMITAS	55
	ELEMENTI NEUTRI NEUTRAL UNITS • ARBEITSELEMENTE • ÉLÉMENTS NEUTRES • MUEBLES NEUTROS	56
	ACCESSORI ACCESSORIES • ZUBEHÖR • ACCESSOIRES • ACCESORIOS	56
LineaBase700 Top	CUCINE A GAS GAS RANGES • GASHERDE • FORNEAUX GAZ • COCINAS A GAS	60
unika700 Top	CUCINE A GAS GAS RANGES • GASHERDE • FORNEAUX GAZ • COCINAS A GAS	60
LineaBase700 Top	CONFIGURAZIONE BRUCIATORI CONFIGURATION BURNERS • KONFIGURATION BRENNER CONFIGURATION BRÛLEURS • CONFIGURACION DE QUEMADORES	61
unika700 Top	CONFIGURAZIONE BRUCIATORI CONFIGURATION BURNERS • KONFIGURATION BRENNER CONFIGURATION BRÛLEURS • CONFIGURACION DE QUEMADORES	61
	CUCINE TUTTAPIASTRA SOLID TOPS • GLUEHPLATTENHERDE • CUISINIÈRES COUP DE FEU • PLACAS RADIANTES	62

INDICE

INDEX • INHALT • SOMMAIRE • ÍNDICE

ACCESSORI

ACCESSORIES • ZUBEHÖR • ACCESSOIRES • ACCESORIOS 62

CUCINE ELETTRICHE

ELECTRIC RANGE • ELEKTROHERDE • FORNEAUX ÉLECTRIQUES • COCINAS ELÉCTRICAS 63

FRIGGITRICI ELETTRICHE CON GRUPPO RESISTENZE SOLLEVABILI

ELECTRIC DEEP FAT FRYERS WITH LIFTABLE HEATING ELEMENTS • ELEKTRO FRITEUSEN MIT DREHBAREN SCHALTKASTEN
FRITEUSES ÉLECTRIQUES AVEC GROUPE RÉSTANCES BASCULANT • FREIDORAS ELÉCTRICAS CON GRUPO DE RESISTENCIAS
EXTRAIBLES 63

CUCINE ELETTRICHE VETROCERAMICA

ELECTRIC RANGES CERAMIC GLASS • ELEKTROHERDE GLASKERAMIK
PLAQUES DE CUISSON EN VITROCÉRAMIQUE • COCINAS ELECTRICAS VETROCERAMICA 64

CUCINA A INDUZIONE

INDUCTION RANGES • INDUKTIONSHERDE
PLAQUES DE CUISSON À INDUCTION • COCINAS ELECTRICAS A INDUCCIÓN 64

ACQUA-GRILL A GAS

GAS STEAMGRILL • DAMPF GRILL, GAS AUSFÜHRUNG
GRILLE VAPEUR À GAZ • VAPOR BARBACOA DE GAS 65

AQUA-GRILL ELETTRICI

ELECTRIC STEAMGRILL • DAMPF GRILL, ELEKTRO AUSFÜHRUNG
GRILLE VAPEUR ÉLECTRIQUE • VAPOR BARBACOA ELÉCTRICO 65

GRIGLIE A PIETRA LAVICA

LAVA ROCK GRILLS • LAVASTEINGRILLS
GRILLES À PIERRE VOLCANIQUE • BARBACOA DE PIEDRA LÁVICA 65

CUOCIPASTA ELETTRICI

ELECTRIC PASTA COOKER • ELEKTRO NUDELKOCHER
CUISEURS À PÂTE ÉLECTRIQUES • CUECE-PASTAS ELÉCTRICOS 66

ACCESSORI PER CUOCIPASTA TOP LT. 20 / LT. 20+20

ACCESSORIES FOR PASTA BOILERS • NUDELKOCHERZUBEHÖR
ACCESSOIRES POUR CUISEUR À PÂTES • ACCESORIOS PARA CUECE-PASTAS 66

FRY TOP A GAS

GAS GRIDDLE PLATES • GAS-GRILLPLATTEN
GRILLES À GAZ • FRY-TOP A GAS 67

FRY TOP ELETTRICI

ELECTRIC GRIDDLE PLATES • ELEKTRO-GRILLPLATTEN
GRILLES ÉLECTRIQUES • FRY-TOP ELÉCTRICOS 68

BAGNO MARIA

BAIN MARIES • BAIN-MARIES • BAIN-MARIE • BAÑO MARÍA 69

SCALDAPATATE

CHIPS SCUTTLES • POMMES FRITES-WÄRMER
BACS DE SALAGE • CALIENTA PATATAS 69

ACCESSORI

ACCESSORIES • ZUBEHÖR • ACCESSOIRES • ACCESORIOS 69

INDICE

INDEX • INHALT • SOMMAIRE • ÍNDICE

	ELEMENTI NEUTRI NEUTRAL UNITS • ARBEITSELEMENTE • ÉLÉMENTS NEUTRES • MUEBLES NEUTROS	70
	ACCESSORI PER ELEMENTI NEUTRI ACCESSORIES FOR NEUTRAL UNITS • ZUBEHÖR FÜR ARBEITSELEMENTE ACCESSOIRES POUR ÉLÉMENTS NEUTRES • ACCESORIOS PARA MUEBLES NEUTROS	71
	ACCESSORI PER CUCINE ACCESSORIES FOR RANGES • ZUBEHÖR FÜR HERDE ACCESSOIRES POUR FORNEAUX • ACCESORIOS PARA COCINA	71
	ACCESSORI PER FRY TOP ACCESSORIES FOR FRY TOP • ZUBEHÖR FÜR GAS-GRILLPLATTEN ACCESSOIRES POUR GRILLADES GAZ • ACCESORIOS PARA FRY-TOP A GAS	72
	ACCESSORI ACCESSORIES • ZUBEHÖR • ACCESSOIRES • ACCESORIOS	72
	ACCESSORI DI COMPLETAMENTO ACCESSORIES • ZUBEHÖR • ACCESSOIRES • ACCESORIOS	74
LineaBase 900	CUCINE A GAS A GIORNO E SU FORNO GAS RANGES WITH AND WITHOUT OVEN • GASHERDE MIT UND OHNE BACKOFEN FORNEAUX GAZ SANS ET AVEC FOUR • COCINAS A GAS	76
unika900	CUCINE A GAS A GIORNO E SU FORNO PPC GAS RANGES WITH AND WITHOUT OVEN • GASHERDE MIT UND OHNE BACKOFEN FORNEAUX GAZ SANS ET AVEC FOUR • COCINAS A GAS	77
	ACCESSORI ACCESSORIES • ZUBEHÖR • ACCESSOIRES • ACCESORIOS	79
LineaBase900	CONFIGURAZIONE BRUCIATORI CONFIGURATION BURNERS • KONFIGURATION BRENNER CONFIGURATION BRÛLEURS • CONFIGURACION DE QUEMADORES	80
unika900	CONFIGURAZIONE BRUCIATORI CONFIGURATION BURNERS • KONFIGURATION BRENNER CONFIGURATION BRÛLEURS • CONFIGURACION DE QUEMADORES	80
	CUCINE TUTTAPIASTRA SOLID TOPS • GLÜHPLATTENHERDE CUI SINIÈRES COUP DE FEU • PLACAS RADIANTES	81
	ACCESSORI ACCESSORIES • ZUBEHÖR • ACCESSOIRES • ACCESORIOS	81
	CUCINA ELETTRICA PIASTRE QUADRE ELECTRIC RANGE WITH SQUARE PLATES • ELEKTROHERDE MIT VIERECKIGEN GUSSPLATTEN FORNEAUX ÉLECTRIQUES AVEC PLAQUES CARRÉES • COCINAS ELÉCTRICAS CON PLANCHAS CUADRADAS	82
	CUCINE VETROCERAMICA RANGES CERAMIC GLASS • HERDE GLASKERAMIK PLAQUES DE CUISSON EN VITROCÉRAMIQUE • COCINAS VETROCERAMICA	83
	CUCINA A INDUZIONE INDUCTION RANGES • INDUKTIONSHERDE PLAQUES DE CUISSON À INDUCTION • COCINAS ELECTRICAS A INDUCCIÓN	83

INDICE

INDEX • INHALT • SOMMAIRE • ÍNDICE

ACCESSORI

ACCESSORIES • ZUBEHÖR • ACCESSOIRES • ACCESORIOS83

BRASIERE MULTIUSO

MULTI COOKING BRATT PANS • ELEKTRO MULTI-BRÄTER
MULTI-SAUTEUSE • SARTEN MULTIPLO84

SCALDAPATATE

CHIPS SCUTTLES • POMMES FRITES-WÄRMER • BAC DE SALAGE • CALIENTAPATATAS84

FRY TOP A GAS

GAS GRIDDLE PLATES • GAS-GRILLPLATTEN • GRILLADES GAZ • FRY-TOP A GAS85

FRY TOP ELETTRICI

ELECTRIC GRIDDLE PLATES • ELEKTRO-GRILLPLATTEN
GRILLADES ÉLECTRIQUES • FRY-TOP ELÉCTRICOS86

AQUA-GRILL A GAS

GAS STEAMGRILL • DAMPF GRILL, GAS AUSFÜHRUNG
GRILLE VAPEUR À GAZ • VAPOR BARBACOA DE GAS87

AQUA-GRILL ELETTRICI

ELECTRIC STEAMGRILL • DAMPF GRILL, ELEKTRO AUSFÜHRUNG
GRILLE VAPEUR ÉLECTRIQUE • VAPOR BARBACOA ELÉCTRICO87

GRIGLIE A PIETRA LAVICA

LAVA ROCK GRILLS • LAVASTEINGRILLS
GRILLES À PIERRE VOLCANIQUE • BARBACOA DE PIEDRA LÁVICA88

ACCESSORI

ACCESSORIES • ZUBEHÖR • ACCESSOIRES • ACCESORIOS88

BAGNO MARIA

BAIN MARIES • BAIN-MARIES • BAIN-MARIE • BAÑO MARÍA89

ACCESSORI

ACCESSORIES • ZUBEHÖR • ACCESSOIRES • ACCESORIOS89

ACCESSORI PER CUCINE

ACCESSORIES FOR RANGES • ZUBEHÖR FÜR HERDE
ACCESSOIRES POUR FORNEAUX • ACCESORIOS PARA COCINA90

ACCESSORI PER FRY TOP

ACCESSORIES FOR FRY TOP • ZUBEHÖR FÜR GRILLPLATTEN
ACCESSOIRES POUR GRILLADES • ACCESORIOS PARA FRY-TOP91

CUOCIPASTA GAS ED ELETTRICI **PPC**

GAS AND ELECTRIC PASTA COOKER • ELEKTRO UND GAS NUDELKOCHER
CUISEURS À PÂTE À GAZ ET ÉLECTRIQUES • CUECE-PASTAS GAS Y ELÉCTRICOS92

ACCESSORI PER CUOCIPASTA

ACCESSORIES FOR PASTA BOILERS • NUDELKOCHERZUBEHÖR
ACCESSOIRES POUR CUISEUR À PÂTES • ACCESORIOS PARA CUECE-PASTAS93

FRIGGITRICI GAS **PPC**

GAS DEEP FAT FRYERS • GAS FRITEUSEN • FRITEUSES GAZ • FREIDORAS A GAS94

INDICE

INDEX • INHALT • SOMMAIRE • ÍNDICE

	FRIGGITRICI ELETTRICHE ELECTRIC DEEP FAT FRYERS • ELEKTRO FRITEUSEN FRITEUSES ÉLECTRIQUES • FREIDORAS ELÉCTRICAS	96
	ACCESSORI PER FRIGGITRICI ACCESSORIES FOR FRYERS • ZUBEHÖR FÜR FRITEUSEN ACCESSOIRES POUR FRITEUSES • ACCESORIOS PARA FREIDORAS	97
	BRASIERE ROVESCIBILI TILTING BRATT PANS • KIPPBRATPFANNEN SAUTEUSES BASCULANTES • SARTENES BASCULANTES	98
	PENTOLE BOILING PANS • KOCHKESSEL • MARMITES • MARMITAS	99
	ACCESSORI PER PENTOLE ACCESSORIES FOR BOILING PANS • KOCHKESSELZUBEHÖR ACCESSOIRES POUR MARMITES • ACCESORIOS PARA MARMITAS	99
	ELEMENTI NEUTRI NEUTRAL UNITS • ARBEITSELEMENTE ÉLÉMENTS NEUTRES • MUEBLES NEUTROS	100
	ACCESSORI ACCESSORIES • ZUBEHÖR • ACCESSOIRES • ACCESORIOS	100
	ACCESSORI DI COMPLEMENTAMENTO ACCESSORIES • ZUBEHÖR • ACCESSOIRES • ACCESORIOS	102
LineaBase900 Top	CUCINE A GAS GAS RANGES • GASHERDE • FORNEAUX GAZ • COCINAS A GAS	104
unika900 Top	CUCINE A GAS GAS RANGES • GASHERDE • FORNEAUX GAZ • COCINAS A GAS	104
LineaBase900 Top	CONFIGURAZIONE BRUCIATORI CONFIGURATION BURNERS • KONFIGURATION BRENNER CONFIGURATION BRÛLEURS • CONFIGURACION DE QUEMADORES	106
unika900 Top	CONFIGURAZIONE BRUCIATORI CONFIGURATION BURNERS • KONFIGURATION BRENNER CONFIGURATION BRÛLEURS • CONFIGURACION DE QUEMADORES	106
	CUCINE TUTTAPIASTRA SOLID TOPS • GLÜHPLATTENHERDE • CUISINIÈRES COUP DE FEU • PLACAS RADIANTES	107
	ACCESSORI ACCESSORIES • ZUBEHÖR • ACCESSOIRES • ACCESORIOS	107
	CUCINE ELETTRICHE ELECTRIC RANGE • ELEKTROHERDE FORNEAUX ÉLECTRIQUES • COCINAS ELÉCTRICAS	108
	CUCINE ELETTRICHE VETROCERAMICA ELECTRIC RANGES CERAMIC GLASS • ELEKTROHERDE GLASKERAMIK PLAQUES DE CUISSON EN VITROCÉRAMIQUE • COCINAS ELÉCTRICAS VETROCERAMICA	108

INDICE

INDEX • INHALT • SOMMAIRE • ÍNDICE

CUCINA A INDUZIONE

INDUCTION RANGES • INDUKTIONSHERDE
PLAQUES DE CUISSON À INDUCTION • COCINAS ELECTRICAS A INDUCCIÓN 109

ACCESSORI

ACCESSORIES • ZUBEHÖR • ACCESSOIRES • ACCESORIOS 109

AQUA-GRILL A GAS

GAS STEAMGRILL • DAMPF GRILL, GAS AUSFÜHRUNG
GRILLE VAPEUR À GAZ • VAPOR BARBACOA DE GAS 110

AQUA-GRILL ELETTRICI

ELECTRIC STEAMGRILL • DAMPF GRILL, ELEKTROAUSFÜHRUNG
GRILLE VAPEUR ÉLECTRIQUE • VAPOR BARBACOA ELÉCTRICO 110

GRIGLIE A PIETRA LAVICA

LAVA ROCK GRILLS • LAVASTEINGRILLS
GRILLES À PIERRE VOLCANIQUE • BARBACOA DE PIEDRA LÁVICA 110

FRY TOP A GAS

GAS GRIDDLE PLATES • GAS-GRILLPLATTEN • GRILLADES GAZ • FRY-TOP A GAS 111

FRY TOP ELETTRICI

ELECTRIC GRIDDLE PLATES • ELEKTRO-GRILLPLATTEN
GRILLADES ÉLECTRIQUES • FRY-TOP ELÉCTRICOS 112

BAGNO MARIA

BAIN MARIES • BAIN-MARIES • BAIN-MARIE • BAÑO MARÍA 113

ACCESSORI

ACCESSORIES • ZUBEHÖR • ACCESSOIRES • ACCESORIOS 113

ELEMENTI NEUTRI

NEUTRAL UNITS • ARBEITSELEMENTE
ÉLÉMENTS NEUTRES • MUEBLES NEUTROS 114

ACCESSORI PER ELEMENTI NEUTRI

ACCESSORIES FOR NEUTRAL UNITS • ZUBEHÖR FÜR ARBEITSELEMENTE
ACCESSOIRES POUR ÉLÉMENTS NEUTRES • ACCESORIOS PARA MUEBLES NEUTROS 114

ACCESSORI PER CUCINE

ACCESSORIES FOR RANGES • ZUBEHÖR FÜR HERDE
ACCESSOIRES POUR FORNEAUX • ACCESORIOS PARA COCINA 115

ACCESSORI PER FRYTOP

ACCESSORIES FOR FRY TOP • ZUBEHÖRE FÜR GAS-GRILLPLATTEN
ACCESSOIRES POUR GRILLADES GAZ • ACCESORIOS PARA FRY-TOP A GAS 116

ACCESSORI

ACCESSORIES • ZUBEHÖR • ACCESSOIRES • ACCESORIOS 116

ACCESSORI DI COMPLEMENTO

ACCESSORIES • ZUBEHÖR • ACCESSOIRES • ACCESORIOS 118

PIANO IGIENICO E PASSANTE

HYGIENIC TOP • HYGIENEPROJEKT
PLANS DE TRAVAIL HYGIÉNIQUES • PLACA HIGIÉNICA 119

INDICE

INDEX • INHALT • SOMMAIRE • ÍNDICE

APPARECCHIATURE PER PASTICCERIA PPC

PASTRY EQUIPMENT • GERÄTE FÜR BÄCKEREI

ÉQUIPEMENTS POUR PÂTISSERIE • APARATOS PARA PASTELERÍA 123

ACCESSORI PER APPARECCHIATURE PER PASTICCERIA

ACCESSORIES FOR PASTRY EQUIPMENTS • ZUBEHÖR FÜR BÄCKEREIGERÄTE

ACCESSOIRES POUR MATÉRIEL DE PÂTISSERIE • ACCESORIOS PARA APARATOS DE PASTELERÍA 124

SALAMANDRE RAPIDE

FAST SALAMANDERS • SCHNELLE SALAMANDER

SALAMANDRES RAPIDES • SALAMANDRAS RÁPIDAS 126

SALAMANDRE

SALAMANDERS • SALAMANDER • SALAMANDRES • SALAMANDRAS 127

ACCESSORI PER SALAMANDRE

ACCESSORIES FOR SALAMANDERS • ZUBEHÖR FÜR SALAMANDER

ACCESSOIRES POUR SALAMANDRES • ACCESORIOS PARA SALAMANDRAS 128

DropIn

SISTEMA DI APPARECCHIATURE DA INCASSO

DROP-IN SYSTEM • SYSTEM VON EINBAUGERÄTEN

SYSTÈME D'APPAREILS DROP-IN • SISTEMA DE EQUIPOS EMPOTRABLES 130

DropIn 600

CUCINE A GAS

GAS RANGES • GASHERDE • FORNEAUX GAZ • COCINAS A GAS 131

CUCINE VETROCERAMICA

RANGES CERAMIC GLASS • HERDE GLASKERAMIK

PLAQUES DE CUISSON EN VITROCÉRAMIQUE • COCINAS VETROCERAMICA 132

CUCINE ELETTRICHE CON PIASTRE ROTONDE

ELECTRIC RANGE WITH ROUND PLATES • ELEKTROHERDE MIT RUNDEN PLATTEN • FORNEAUX

ÉLECTRIQUES AVEC PLAQUES ARRONDIES • COCINAS ELÉCTRICAS CON PLANCHAS REDONDAS 132

FRY TOP ELETTRICI

ELECTRIC GRIDDLE PLATES • ELEKTRO-GRILLPLATTEN

GRILLADES ÉLECTRIQUES • FRY-TOP ELÉCTRICOS 133

BAGNO MARIA

BAIN MARIES • BAIN-MARIES • BAIN-MARIE • BAÑO MARÍA 134

CUOCIPASTA ELETTRICI

ELECTRIC PASTA COOKER • ELEKTRO NUDELKOCHER

CUISIÉURS À PÂTE ÉLECTRIQUES • CUECE-PASTAS ELÉCTRICOS 134

SCALDAPATATE

CHIPS SCUTTLES • POMMES FRITES-WÄRMER • BACS DE SALAGE • CALIENTA PATATAS 134

FRIGGITRICI ELETTRICHE

ELECTRIC DEEP FAT FRYERS • ELEKTRO FRITEUSEN

FRITEUSES ÉLECTRIQUES • FREIDORAS ELÉCTRICAS 135

DropIn 700

CUCINE A GAS

GAS RANGES • GASHERDE • FORNEAUX GAZ • COCINAS A GAS 136

CUCINE TUTTAPIASTRA

SOLID TOPS • GLÜHPLATTENHERDE • CUISINIÈRES COUP DE FEU • PLACAS RADIANTES 136

INDICE

INDEX • INHALT • SOMMAIRE • ÍNDICE

CUCINE VETROCERAMICA

RANGES CERAMIC GLASS • HERDE GLASKERAMIK
PLAQUES DE CUISSON EN VITROCÉRAMIQUE • COCINAS VETROCERAMICA 137

CUCINA A INDUZIONE

INDUCTION RANGES • INDUKTIONSHERDE
PLAQUES DE CUISSON À INDUCTION • COCINAS ELECTRICAS A INDUCCIÓN 137

CUCINA ELETTRICA PIASTRE QUADRE

ELECTRIC RANGE WITH SQUARE PLATES • ELEKTROHERDE MIT VIERECKIGEN GUSSPLATTEN
FORNEAUX ÉLECTRIQUES AVEC PLAQUES CARRÉES • COCINAS ELÉCTRICAS CON PLANCHAS CUADRADAS 138

CUCINE ELETTRICHE CON PIASTRE ROTONDE

ELECTRIC RANGE WITH ROUND PLATES • ELEKTROHERDE MIT RUNDEN PLATTEN
FORNEAUX ÉLECTRIQUES AVEC PLAQUES ARRONDIES • COCINAS ELÉCTRICAS CON PLANCHAS REDONDAS 138

FRY TOP ELETTRICI

ELECTRIC GRIDDLE PLATES • ELEKTRO-GRILLPLATTEN
GRILLADES ÉLECTRIQUES • FRY-TOP ELÉCTRICOS 139

BRASIERE MULTIUSO

MULTI COOKING BRATT PANS • ELEKTRO MULTI-BRÄTER
MULTI-SAUTEUSE • SARTEN MULTIPLIO 139

BAGNO MARIA

BAIN MARIES • BAIN-MARIES • BAIN-MARIE • BAÑO MARÍA 140

CUOCIPASTA ELETTRICI

ELECTRIC PASTA-COOKER • ELEKTRO NUDELKOCHER
CUISEURS À PÂTE ÉLECTRIQUES • CUECE-PASTAS ELÉCTRICOS 140

FRIGGITRICI ELETTRICHE

ELECTRIC DEEP FAT FRYERS • ELEKTRO FRITEUSEN
FRITEUSES ÉLECTRIQUES • FREIDORAS ELÉCTRICAS 141

CONDIZIONI GENERALI DI VENDITA

GENERAL SALES CONDITION • ALLGEMEINE VERKAUFSBEDINGUNGEN
CONDITIONS GÉNÉRALES DE VENTE • CONDICIONES GENERALES DE VENTA 142



www.imq.it

CERTIFICATO N. **9190.GIOK**
CERTIFICATE N.

SI CERTIFICA CHE IL SISTEMA DI GESTIONE PER LA QUALITA' DI
WE HEREBY CERTIFY THAT THE QUALITY MANAGEMENT SYSTEM OPERATED BY

GIORIK SPA

VIA CAVALIERI DI VITTORIO VENETO 14 - 32036 SEDICO (BL)
UNITA' OPERATIVE / OPERATIVE UNITS

VIA CAVALIERI DI VITTORIO VENETO 14 - 32036 SEDICO (BL)
E' CONFORME ALLA NORMA / IS IN COMPLIANCE WITH THE STANDARD

ISO 9001:2015

PER LE SEGUENTI ATTIVITA' / FOR THE FOLLOWING ACTIVITIES

Progettazione, fabbricazione e assistenza tecnica di apparecchiature
professionali per la ristorazione collettiva
*Design, production and technical assistance of professional kitchen
equipment for catering and food service facilities*

Ulteriori informazioni riguardanti l'applicabilità dei requisiti ISO 9001:2015 possono essere ottenute consultando l'organizzazione
Further clarifications regarding the applicability of ISO 9001:2015 requirements may be obtained by consulting the organization

IL PRESENTE CERTIFICATO E' SOGGETTO AL RISPETTO DEL
REGOLAMENTO PER LA CERTIFICAZIONE DEI SISTEMI DI GESTIONE
THE USE AND THE VALIDITY OF THE CERTIFICATE SHALL SATISFY THE
REQUIREMENTS OF THE RULES FOR CERTIFICATION OF MANAGEMENT SYSTEMS

IMQ S.p.A. - VIA QUINTILIANO, 43 - 20138 MILANO ITALY
Management Systems Division - Flavio Orsago

CISQ is a member of



IONet, the association of the world's first class
certification bodies, is the largest provider of management
System Certification in the world.
IONet is composed of more than 30 bodies and counts
over 150 subsidiaries all over the globe.



SGQ N° 005 A

Ministero degli Interni - M.I.A.
Ministero delle Infrastrutture e
Trasporti - M.I.T.
Ministero della Sanità - M.S.
Ministero dell'Agricoltura e
Foreste - M.A.F.

IAF: 18, 19

La validità del certificato di certificazione è subordinata al rispetto delle norme e al rispetto delle procedure operative.
The validity of the certificate is subject to compliance with the standards and to the respect of the operating procedures.



Organismo di Certificazione Fedelato CISQ
www.imq.it



www.cisq.com

CISQ è la Federazione Italiana di Organismi di
Certificazione dei sistemi di gestione aziendale.
CISQ is the Italian Federation of management
system Certification Bodies.



THE INTERNATIONAL CERTIFICATION NETWORK

CERTIFICATE

CISQ/IMQ has issued an IQNet recognized certificate that the organization:

GIORIK SPA

VIA CAVALIERI DI VITTORIO VENETO 14 - 32036 SEDICO (BL)

has implemented and maintains a

Quality Management System

for the following scope:

Design, production and technical assistance of professional kitchen equipment for catering and food service facilities

Further clarifications regarding the applicability of ISO 9001:2015 requirements may be obtained by consulting the organization

which fulfills the requirements of the following standard:

ISO 9001:2015

This attestation is directly linked to the IQNet Partner's original certificate and shall not be used as a stand-alone document

Registration Number: IT - 20777



*Alex Stoichitoiu
President of IQNET*



*Ing. Claudio Provetti
President of CISQ*

IQNet Partners*:

AENOR Spain AFNOR Certification France APCER Portugal CCC Cyprus CISQ Italy
CQC China CQM China CQS Czech Republic Cro Cert Croatia DQS Holding GmbH Germany FCAV Brazil
FONDONORMA Venezuela ICONTEC Colombia Inspecta Sertificiointi Oy Finland INTECO Costa Rica
IRAM Argentina JQA Japan KFO Korea MIRTEC Greece MSZT Hungary Neunko AS Norway NSAI Ireland
NYCE-SIGE Mexico PCBC Poland Quality Austria Austria RR Russia SII Israel SIQ Slovenia
SIRIM QAS International Malaysia SQS Switzerland SRAC Romania TEST St Petersburg Russia TSE Turkey YUQS Serbia
IQNet is represented in the USA by: AFNOR Certification, CISQ, DQS Holding GmbH and NSAI Inc.

* The list of IQNet partners is valid at the time of issue of this certificate. Updated information is available under www.iqnet-certification.com

CERTIFICAZIONI PRODOTTO

PRODUCT CERTIFICATIONS

CE

IMQ



LEGENDA E NOTE

LEGEND AND NOTES • LEGENDE UND ANMERKUNGEN • LÉGENDE ET NOTES • LEYENDA Y NOTAS



APPARECCHIATURE ELETTRICHE

ELECTRIC EQUIPMENT • ELEKTRO GERÄTE • ÉQUIPEMENTS ÉLECTRIQUES • APARATOS ELÉCTRICOS



APPARECCHIATURE A GAS

GAS EQUIPMENT • GAS GERÄTE • ÉQUIPEMENTS À GAZ • APARATOS A GAS

In caso di installazione di apparecchiature su mobile con potenza totale superiore ai 15 kW sprovviste di cappa di aspirazione, è necessario il camino antiventto. Tutte le apparecchiature a gas presenti nell'attuale listino sono predisposte all'utilizzo con gas metano (G20). Tutte le apparecchiature disponibili in stock per consegne immediate vengono spedite con la dotazione standard Giorik (come specificata nel presente listino). Ogni modifica della dotazione o personalizzazione o ancora modifica del tipo di alimentazione a gas/elettrica sarà soggetta ad un sovrapprezzo compreso tra il 3% ed il 5% a seconda del tipo di modifica. Tutte le apparecchiature presenti nell'attuale listino sono prodotte in conformità al marchio CE.

For installation of all gas cooking equipment with total output over 15 kW and with no extraction hood/canopy, anti draught flue is required. All gas equipment on this price list are for natural gas (G20) installation. All equipment available from stock for immediate delivery is to be shipped with the standard Giorik features as shown in the current price list. Any changes of their features, gas/electric feed power, will be charged with an extra cost between 3% and 5% according to type of modification. All equipment on this price list are manufactured in compliance with CE stamp.

gio60

GIORIK
INNOVATIVE COOKING EQUIPMENT SINCE 1963

PIANI COTTURA

COOKING TOPS • KOCHPLATTEN • PLAQUES DE CUISSON • PLANOS DE COCCIÓN

CODICE Code Kode Code Codigo	 (A x B x C) mm	VOL./PESO Vol./Weight Vol./Gewicht Vol./Poids Vol./Pesos	GAS	VAC 230-1N 50/60 Hz	VAC 400-3N 50/60 Hz	PREZZO Price Preis Prix Precio
		m ³ /kg	kW	kW	kW	€

4 fuochi con forno elettrico • 4 burners boiling top with electric oven • Gas-Kocher mit 4 Kochstellen und Heissluftbackofen • 4 Feux à gaz avec four électrique • 4 Fuegos con horno eléctrico



LPG694E

600x600x900

0,40/89

19
2 x 3,5
2 x 6

2,2

2.916,00

4 piastre su forno elettrico • 4 plates on electric oven • 4 Platten mit Elektroofen • 4 plaques sur four électrique • 4 placas sobre horno eléctrico

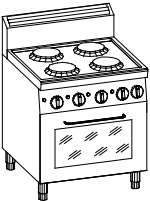

LPE674E

600x600x900
4 x Ø180

0,46/80

10,2

3.108,00

4 piastre vetroceramica su forno elettrico • 4 plates with ceramic glass on electric oven • 4 Glaskeramik Platten mit Elektroofen • 4 plaques en vitrocéramique sur four électrique • 4 placas de vitrocerámica sobre horno eléctrico

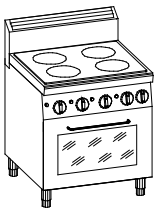

LPV674E

600x600x900
1 x Ø180
2 x Ø230
1 x Ø145

0,46/59

10,2

3.470,00

PIANI COTTURA





gio60

gio60

COOKING TOPS • KOCHPLATTEN • PLAQUES DE CUISSON • PLANOS DE COCCIÓN









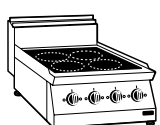

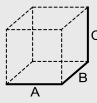
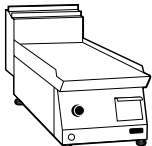





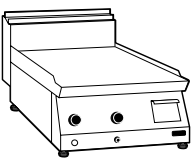

CODICE Code Kode Code Codigo		VOL./PESO Vol./Weight Vol./Gewicht Vol./Poids Vol./Pesos	GAS	VAC 230-1N 50/60 Hz	VAC 400-3N 50/60 Hz	PREZZO Price Preis Prix Precio
	(A x B x C) mm	m ³ /kg	kW	kW	kW	€

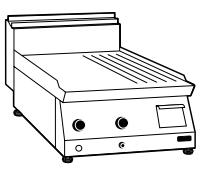
Piani cottura • Cooking tops • Kochplatten • Plaques de cuisson • Planos de cocción

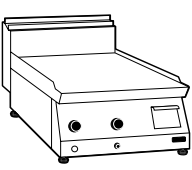
	⚡	LPE4721	400x600x290 2 x Ø180	0,18/21		4		668,00
		LPE6741	600x600x290 4 x Ø180	0,25/30		8		1.038,00
	⚡	LPE6743	600x600x290 4 x Ø180	0,25/30			8	1.038,00
	🔥	LPG4920	400x600x290	0,18/20	9,5 1 x 3,5 1 x 6			1.077,00
	🔥	LPG6940	600x600x290	0,25/28	19 2 x 3,5 2 x 6			1.792,00

Piani cottura in vetroceramica • Vitroceramic cooking tops • Keramikkocher
Plaques de cuisson en vitroc ramique • Planos de cocc n de vitrocer mica

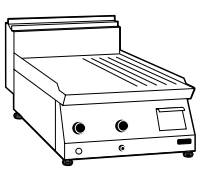
	⚡	LPV4721	400x600x290 1 x Ø180 1 x Ø230	0,18/15		4,3		1.582,00
	⚡	LPV6741	600x600x290 1 x Ø180 2 x Ø230 1 x Ø145	0,25/21		8		2.365,00
	⚡	LPV6743	600x600x290 1 x Ø180 2 x Ø230 1 x Ø145	0,25/21			8	2.249,00

	CODICE Code Kode Code Codigo	 (A x B x C) mm	VOL./PESO Vol./Weight Vol./Gewicht Vol./Poids Vol./Pesos m ³ /kg	GAS kW	VAC		PREZZO Price Preis Prix Precio €
					230-1N 50/60 Hz	400-3N 50/60 Hz	
	Liscio • Smooth • Glatt • Lisse • Liso						
	 LGG4900	400x600x290	0,18/41	4,6			1.494,00
	<i>Non disponibile per la Comunità Europea • Not available for UE market</i>						
	 LGG4900X	400x600x290	0,18/41	4,6			1.730,00
	 LGG4930*	400x600x290	0,18/41	4,6			1.976,00
	Rigato • Ribbed • Gerillt • Nervuré • Acanalado						
	 LGG4910	400x600x290	0,18/41	4,6			1.556,00
	<i>Non disponibile per la Comunità Europea • Not available for UE market</i>						
	 LGG4910X	400x600x290	0,18/41	4,6			1.772,00
	Liscio • Smooth • Glatt • Lisse • Liso						
	 LGG6900	600x600x290	0,25/60	7,6			2.087,00
	<i>Non disponibile per la Comunità Europea • Not available for UE market</i>						
	 LGG6900X	600x600x290	0,25/60	7,6			2.370,00
	 LGG6930*	600x600x290	0,25/60	7,6			2.549,00
	(1/2 + 1/2) Liscio-Rigato • Smooth-Ribbed • Glatt-Gerillt • Lisse-Nervuré • Liso-Acanalado						
	 *LGG6910	600x600x290	0,25/60	7,6			2.202,00
	<i>Non disponibile per la Comunità Europea • Not available for UE market</i>						
	 LGG6910X	600x600x290	0,25/60	7,6			2.466,00
	Liscio • Smooth • Glatt • Lisse • Liso						
	 LGG6970	1000x600x290	0,31/95	13,8			3.023,00
	<i>Non disponibile per la Comunità Europea • Not available for UE market</i>						
	 LGG6970X	1000x600x290	0,31/95	13,8			3.711,00
	 LGG6790*	1000x600x290	0,31/95	13,8			3.808,00
	(2/3 + 1/3) Liscio-Rigato • Smooth-Ribbed • Glatt-Gerillt • Lisse-Nervuré • Liso-Acanalado						
	 LGG6960	1000x600x290	0,31/95	13,8			3.354,00
	<i>Non disponibile per la Comunità Europea • Not available for UE market</i>						
	 LGG6960X	1000x600x290	0,31/95	13,8			3.938,00

Non disponibile per la comunità Europea • Not available for UE market • Nicht erhältlich für die Europäische Gemeinschaft • Non disponible pour la Communauté européenne • No disponible para la Comunidad europea

X Piastra in acciaio inossidabile Duplex 2304 • Duplex 2304 stainless steel plate • Platte aus rostfreiem Stahl Duplex 2304 • Plaque en acier inoxydable Duplex 2304 • Placa de acero inoxidable Duplex 2304

* Versione con piastra cromata • Chrome-plated surface • Ausführung mit Chromplatte • Version avec plaque chromée • Versión con placha cromada



FRY TOP

GRIDDLE • GRILLPLATTEN • GRILLS • FRY-TOP

gio60

gio60

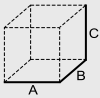
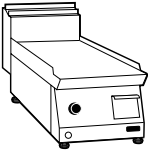
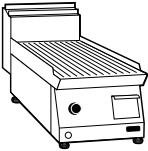
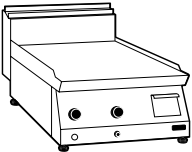
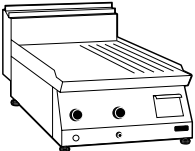
CODICE Code Kode Code Codigo	 (A x B x C) mm	VOL./PESO Vol./Weight Vol./Gewicht Vol./Poids Vol./Pesos m ³ /kg	GAS kW	VAC	VAC	PREZZO Price Preis Prix Precio €
				230-1N 50/60 Hz kW	400-3N 50/60 Hz kW	
Liscio • Smooth • Glatt • Lisse • Liso						
	⚡ LGE4901	400x600x290	0,18/41		3,6	1.327,00
		Non disponibile per la Comunità Europea • Not available for UE market				
	⚡ LGE4901X	400x600x290	0,18/41		3,6	1.583,00
⚡ LGE4931*	400x600x290	0,18/41		3,6	1.783,00	
Rigato • Ribbed • Gerillt • Nervuré • Acanalado						
	⚡ LGE4911	400x600x290	0,18/41		3,6	1.373,00
		Non disponibile per la Comunità Europea • Not available for UE market				
⚡ LGE4911X	400x600x290	0,18/41		3,6	1.623,00	
Liscio • Smooth • Glatt • Lisse • Liso						
	⚡ LGE6901	600x600x290	0,25/60		7,2	1.809,00
		Non disponibile per la Comunità Europea • Not available for UE market				
	⚡ LGE6903	600x600x290	0,25/60		7,2	1.659,00
		Non disponibile per la Comunità Europea • Not available for UE market				
	⚡ LGE6901X	600x600x290	0,25/60		7,2	2.087,00
⚡ LGE6903X	600x600x290	0,25/60		7,2	1.896,00	
⚡ LGE6931*	600x600x290	0,25/60		7,2	2.262,00	
⚡ LGE6933*	600x600x290	0,25/60		7,2	2.262,00	
(1/2 + 1/2) Liscio-Rigato • Smooth-Ribbed • Glatt-Gerillt • Lisse-Nervuré • Liso-Acanalado						
	⚡ LGE6921	600x600x290	0,25/60		7,2	1.904,00
		Non disponibile per la Comunità Europea • Not available for UE market				
	⚡ LGE6923	600x600x290	0,25/60		7,2	1.950,00
		Non disponibile per la Comunità Europea • Not available for UE market				
⚡ LGE6921X	600x600x290	0,25/60		7,2	2.190,00	
⚡ LGE6923X	600x600x290	0,25/60		7,2	2.228,00	

Non disponibile per la comunità Europea • Not available for UE market • Nicht erhältlich für die Europäische Gemeinschaft • Non disponible pour la Communauté européenne • No disponible para la Comunidad europea

X Piastra in acciaio inossidabile Duplex 2304 • Duplex 2304 stainless steel plate • Platte aus rostfreiem Stahl Duplex 2304 • Plaque en acier inoxydable Duplex 2304 • Placa de acero inoxidable Duplex 2304

* Versione con piastra cromata • Chrome-plated surface • Ausführung mit Chromplatte • Version avec plaque chromée • Versión con placha cromada





FRY TOP • GRIGLIE A PIETRA LAVICA

GRIDDLE • GRILLPLATTEN • GRILLS • FRY-TOP
LAVASTONE GRILLS • LAVASTEINGRILLS • GRILLS À PIERRE DE LAVE • PARILLAS CON PIEDRA VOLCÁNICA

CODICE Code Kode Code Codigo	 (A x B x C) mm	VOL./PESO Vol./Weight Vol./Gewicht Vol./Poids Vol./Pesos m ³ /kg	GAS kW	VAC 230-1N 50/60 Hz kW	VAC 400-3N 50/60 Hz kW	PREZZO Price Preis Prix Precio €
--	---	--	-----------	---------------------------------	---------------------------------	---

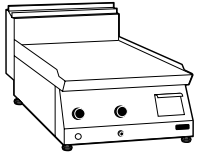

Liscio • Smooth • Glatt • Lisse • Liso



 LGE6970	1000x600x290	0,31/95			10,8	2.862,00
<i>Non disponibile per la Comunità Europea • Not available for UE market</i>						
 LGE6970X	1000x600x290	0,31/95			10,8	3.202,00

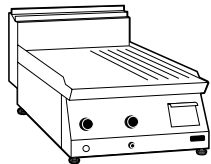

(2/3 + 1/3) Liscio-Rigato • Smooth-Ribbed • Glatt-Gerillt • Lisse-Nervuré • Liso-Acanalado

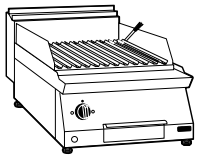

 LGE6963	1000x600x290	0,31/95			10,8	2.738,00
<i>Non disponibile per la Comunità Europea • Not available for UE market</i>						
 LGE6963X	1000x600x290	0,31/95			10,8	3.207,00
 LGE6967*	1000x600x290	0,31/95			10,8	3.478,00

Griglie a pietra lavica • Lavastone grills • Lavasteingrills
Grills à pierre de lave • Parillas con piedra volcanica



 LTG6700	600x600x290	0,25/51	7,3		Griglia carne Grill for meat Fleischgrill	1.953,00
 LTG8700	800x600x290	0,35/65	14		Grill pour viande Rejilla carne	2.481,00

Non disponibile per la comunità Europea • Not available for UE market • Nicht erhältlich für die Europäische Gemeinschaft • Non disponible pour la Communauté européenne • No disponible para la Comunidad europea

X Piastra in acciaio inossidabile Duplex 2304 • Duplex 2304 stainless steel plate • Platte aus rostfreiem Stahl Duplex 2304 • Plaque en acier inoxydable Duplex 2304 • Placa de acero inoxidable Duplex 2304

* Versione con piastra cromata • Chrome-plated surface • Ausführung mit Chromplatte • Version avec plaque chromée • Versión con placha cromada



CUOCIPASTA



gio60

gio60

PASTA COOKER • NUDELKOCHER • CUISEURS À PÂTE • CUECEPASTAS

CODICE Code Kode Code Codigo	 (A x B x C) mm	VOL./PESO Vol./Weight Vol./Gewicht Vol./Poids Vol./Pesos m ³ /kg	GAS kW	VAC 230-1N 50/60 Hz kW	VAC 400-3N 50/60 Hz kW	PREZZO Price Preis Prix Precio €
--	---	--	-----------	---------------------------------	---------------------------------	---



 LCP6713	600x600x850 26 Lt. 2/3 GN	0,54/47			5,5	2.376,00
 LCG6700	600x600x850 26 Lt. 2/3 GN	0,54/63	10			2.521,00

I prezzi dei cuocipasta **NON COMPREDONO I CESTELLI** • The **BASKETS ARE NOT INCLUDED** in the price of pasta cookers • Die Preise der Nudelkochern **ENTHALTEN KEINE KÖRBE** • Les prix des cuiseurs a pâtes **NE COMPRENENT PAS LES PANIERS** • Los precios de los cuecepastas **NO INCLUYEN LOS CESTOS**.

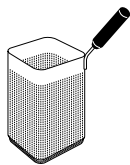

Cestelli • Baskets • Körbe • Paniers • Cestos						
2003075	2/3 GN		mm 298x334x215H			168,00
2003046	1/3 GN (A)		mm 290x160x215H			132,00
2003077	1/3 GN (B)		mm 296x143x215H			137,00
2003045	1/6 GN (dx)		mm 163x143x215H			106,00
2003047	1/6 GN (sx)		mm 163x143x215H			106,00
2003080	1/6 GN (R)		Ø mm 152x215H			100,00

ALCUNI ESEMPI DI ABBINAMENTI

Some examples of combinations
Einige Kombinationsbeispiele
Quelques exemples de combinaison
Algunos ejemplos de combinaciones posibles

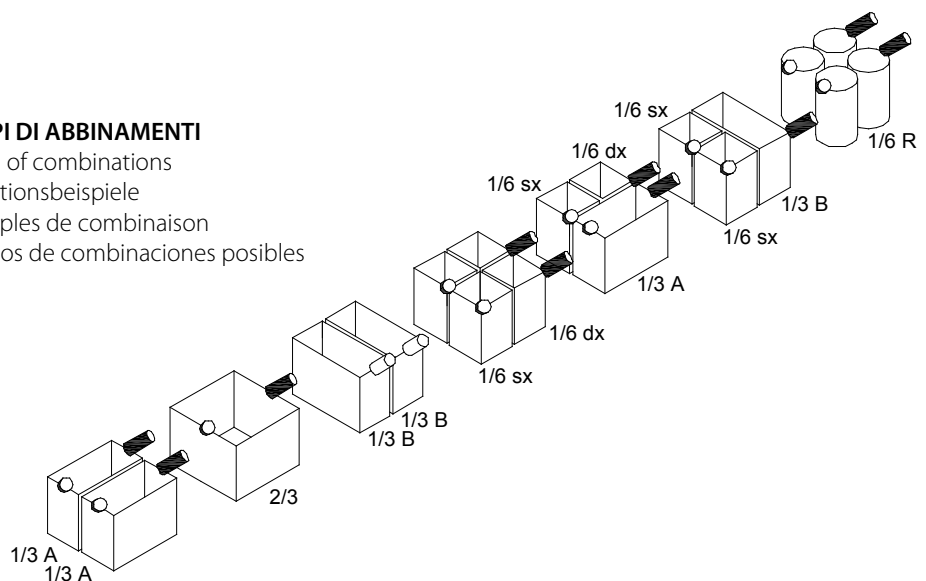



FRIGGITRICI DA TAVOLO • SCALDAPATATE

COUNTER FRYERS • TISCHFRITEUSEN • FRITEUSES POSABLES • FREIDORAS DE MESA
CHIPS SCUTTLES • POMMES FRITES-WÄRMER • BAC DE SALAGE • CALIENTAPATATAS

CODICE Code Kode Code Codigo	 (A x B x C) mm	VOL./PESO Vol./Weight Vol./Gewicht Vol./Poids Vol./Pesos m ³ /kg	GAS kW	VAC 230-1N 50/60 Hz kW	VAC 400-3N 50/60 Hz kW	PREZZO Price Preis Prix Precio €
--	---	--	-----------	---------------------------------	---------------------------------	---



Friggitrici con resistenze fisse • Fryers with fixed heating elements • Friteusen mit festen Widerständen
Friteuses avec résistances fixes • Freidoras con resistencias fijas



 LFE4750	400x600x290 6 Lt.	0,18/22		3,3		1.127,00
 LFE6750	600x600x290 6+6 Lt.	0,25/31		6,6		1.916,00

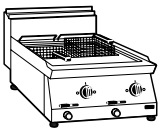

Friggitrici con gruppo resistenze sollevabili • Fryers with liftable heating elements • Friteusen mit drehbaren Schaltkasten • Friteuses avec groupe résistances basculant • Freidoras con grupo de resistencias extraíbles



 LFE4783	400x600x290 8 Lt.	0,18/22			6,3	1.397,00
 LFE6783	600x600x290 8+8 Lt.	0,25/31			12,6	2.356,00
 LFE4910	400x600x290 10 Lt.	0,18/22			10,00	1.523,00
 LFE6910	600x600x290 10+10 Lt.	0,25/31			10+10	2.489,00

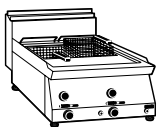

Friggitrici gas • Gas fryers • Gasfriteusen • Friteuses gaz • Freidoras de gas



 LFG4710	400x600x290 8 Lt.	0,18/29	6,7			2.018,00
 LFG6720	600x600x290 8+8 Lt.	0,25/48	13,4			3.443,00

Scaldapatate • Chips scuttles • Pommes Frites-Wärmer • Bac de salage • Calientapatatas



 LSE4711	400x600x290 GN 2/3	0,18/22		1,38		845,00
 LSR4911	400x390x410	0,12/13		0,75		735,00

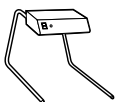

LAVELLO • MODULI NEUTRI • BAGNO MARIA

gio60

gio60

WASH BASIN - NEUTRAL UNITS - BAIN-MARIE • SPÜHLBECKEN - NEUTRALE ELEMENTE -
WASSERBAD • ÉVIER - ÉLÉMENTS NEUTRES - BAIN MARIE • PILA - MÓDULOS NEUTROS - BAÑO MARÍA

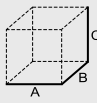
CODICE Code Kode Code Codigo		VOL./PESO Vol./Weight Vol./Gewicht Vol./Poids Vol./Pesos	GAS	VAC 230-1N 50/60 Hz	VAC 400-3N 50/60 Hz	PREZZO Price Preis Prix Precio
	(A x B x C) mm	m ³ /kg	kW	kW	kW	€

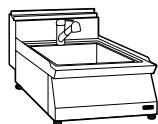

Lavello • Wash basin • Spühlbecken • Évier • Pila

LEL6700*	600x600x290	0,25/21				984,00
-----------------	-------------	---------	--	--	--	---------------

Moduli neutri • Neutral elements • Neutrale elemente • Éléments neutres • Módulos neutros

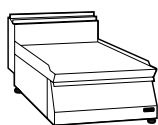

LEN4700**	400x600x290	0,18/28				572,00
------------------	-------------	---------	--	--	--	---------------

LEN6700**	600x600x290	0,25/38				688,00
------------------	-------------	---------	--	--	--	---------------

Bagno maria • Bain-marie • Wasserbad • Bain marie • Baño maría

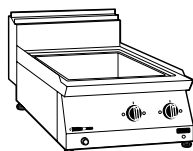

LBE4711	400x600x290 GN 1/2 + GN 1/4	0,18/21		1,4		1.011,00
----------------	--------------------------------	---------	--	-----	--	-----------------

LBE6711	600x600x290 GN 1/2 + 2 x GN 1/4	0,25/38		2,8		1.341,00
----------------	------------------------------------	---------	--	-----	--	-----------------

* Con miscelatore e sifone • With mixer and Siphon • Mischer und Siphon • Avec mitigeur et siphon • Con mezclador y sifón

** Con cassetto • With drawer • Mit Schublade • Avec tiroir • Con Cajón

CUOCIPASTA ELETTRICI

ELECTRIC PASTA COOKER • ELEKTRO NUDELKOCHER
CUISEURS À PÂTE ÉLECTRIQUES • CUECE-PASTAS ELÉCTRICOS

CODICE Code Kode Code Codigo		VOL./PESO Vol./Weight Vol./Gewicht Vol./Poids Vol./Pesos	GAS	VAC 400-3N 50/60 Hz	CAPACITA' Capacity Inhalt Capacité Capacidad	PREZZO Price Preis Prix Precio
	(A x B x C) mm	m ³ /kg	kW	kW	Lt.	€

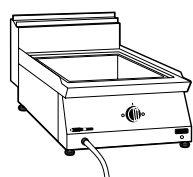



LCP4900	400x600x290	0,2/25		5,5	20	1.520,00
----------------	-------------	--------	--	-----	----	-----------------

LCP6900	600x600x290	0,28/45		7,4	28	1.900,00
----------------	-------------	---------	--	-----	----	-----------------

Per i cesti vedi pagina 66 • For baskets see page 66 • Für Körbe siehe Seite 66 • Pour les paniers voir page 66
Para los cestos ver página 66

ACCESSORI

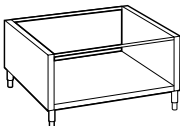
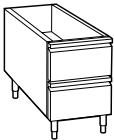
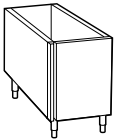
ACCESSORIES • ZUBEHÖR • ACCESSOIRES • ACCESORIOS

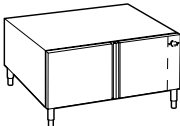





CODICE Code Kode Code Codigo	 (A x B x C) mm	VOL./PESO Vol./Weight Vol./Gewicht Vol./Poids Vol./Pesos	GAS	VAC		PREZZO Price Preis Prix Precio
				230-1N 50/60 Hz	400-3N 50/60 Hz	
		m ³ /kg	kW	kW	kW	
Con ripiano • With shelf • Mit Schublade • Avec étagère • Con estante						
	SUL0140	400x550x580	0,13/14			392,00
	SUL0160	600x550x580	0,19/17			430,00
	SUL0180	800x550x580	0,22/19			523,00
Armadio neutro con cassetti • Neutral cupboard with drawers • Neutraler Schrank mit Schubladen Armoire neutre avec tiroirs • Armario neutro con cajones						
	SUL0420	400x550x580	0,13/26			910,00
Armadio neutro con ripiani • Neutral cupboard with shelf • Neutraler Schrank mit Zwischenboden Armoire neutre avec étagère • Armario neutro con estante						
	SUL0440	400x550x580	0,13/17			551,00
	SUL0660	600x550x580	0,19/24			637,00
	SUL0880	800x550x580	0,25/25			760,00
	SUL1000	1000x550x580	0,31/38			913,00
	SUL1021	1000x550x580	0,31/41	con 2 cassetti • with 2 drawers mit 2 Schubladen • avec 2 tiroirs con 2 cajones		1.272,00
	SUL1260	1200x550x580	0,37/44			1.125,00
Armadio caldo con ripiano • Warm cupboard with shelf • Warmhalteschrank mit Zwischenboden Armoire chaude avec étagère • Armadio caliente con estante						
	SUL1200	1200x550x580	0,37/55		0,9	1.459,00



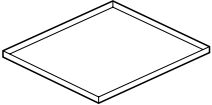
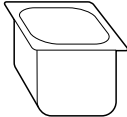

ACCESSORI

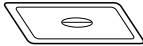
ACCESSORIES • ZUBEHÖR • ACCESSOIRES • ACCESORIOS

gio60

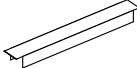
gio60

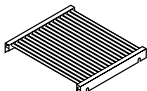
CODICE Code Kode Code Codigo	 (A x B x C) mm	VOL./PESO Vol./Weight Vol./Gewicht Vol./Poids Vol./Pesos m ³ /kg	GAS kW	VAC 230-1N 50/60 Hz kW	VAC 400-3N 50/60 Hz kW	PREZZO Price Preis Prix Precio €
Griglia forno • Chromed wire oven shelf • Backofenrost • Grille chromée • Parrilla horno cromada						
 2020306						23,00
Padella leccarda forno snack • Snack oven drip pan • Fettauffangschale Snack-Ofen • Bac lèche-frite four snack Sartén grasera horno snack						
 2020307						33,00
Bacinelle e coperchi per bagno maria • Basins and lids for bain-marie • Behälter und Deckel für Wasserbad Bacs et couvercles pour bain marie • Recipientes y tapas para el baño maría						
2103135	GN 1/4 H150	Per • For • Für • Pour • Para: LBE4711 • LBE6711				55,00
2103142	GN 1/3 H150	Per • For • Für • Pour • Para: LBE6711				51,00
 2103080	GN 1/2 H150	Per • For • Für • Pour • Para: LBE4711 • LBE6711				72,00
2103107	GN 2/3 H150	Per • For • Für • Pour • Para: LSE4711				89,00
2103134	GN 1/1 H150	Per • For • Für • Pour • Para: LBE6711				108,00
2103202		Per • For • Für • Pour • Para: GN 1/4				23,00
2103077		Per • For • Für • Pour • Para: GN 1/2				21,00
 2103201		Per • For • Für • Pour • Para: GN 2/3				39,00
2103106		Per • For • Für • Pour • Para: GN 1/1				62,00
Coperchio per cuocipasta • Lid for pasta cooker • Deckel für Nudelkocher • Couvercle pour cuiseur à pâtes • Tapa para cuecepastas						
 2004151		1 per vasca • 1 piece each tank • 1 pro Becken • 1 par cuve • 1 pour cuba				39,00
Cestelli per friggatrici • Baskets for fryers • Körbe für Friteusen • Paniers pour friteuses • Cestos para freidoras						
2004579	180x270x120h	Per • For • Für • Pour • Para: LFE4750 • LFE6750				66,00
2003002	113x290x120	Per • For • Für • Pour • Para: LFG4710 • LFG6720				53,00
 2003003	230x290x120	Per • For • Für • Pour • Para: LFG4710 • LFG6720				70,00
2013949	230x280x100h	Per • For • Für • Pour • Para: LFE4783 • LFE6783 • LFE4910 • LFE6910				70,00
2014725	110x280x100h	Per • For • Für • Pour • Para: LFE4783 • LFE6783 • LFE4910 • LFE6910				66,00

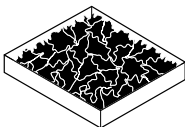
CODICE Code Kode Code Codigo	 (A x B x C) mm	VOL./PESO Vol./Weight Vol./Gewicht Vol./Poids Vol./Pesos m ³ /kg	GAS kW	VAC	VAC	PREZZO Price Preis Prix Precio €
				230-1N 50/60 Hz kW	400-3N 50/60 Hz kW	
Traversino per bagno maria • Support for bain marie • Querstrebe für Bain-Marie • Traverse pour bain-marie Larguero para baño maría						
 2009098	159x23xGN1/1					8,00
2009099	526x23xGN1/1					11,00
2009100	328x23xGN1/2					10,00
Coprigiunto • Butting strip • Zwischensteg • Barrette de composition • Cubrejuntas						
 2009047	Per giunzione standard • Standard butting strip • Für Standard-Verbindung Pour jonction standard • Junta estándar					29,00
Raschietto per fry top • Scraper for fry top • Kratzer für Grillplatten • Grattoir pour grills • Raspador para fry top						
 7080100	Per piastra liscia • For smooth plate • Für glatte Platte Pour plaque lisse • Para plancha lisa					58,00
7080101	Per piastra rigata • For ribbed plate • Für gerillte Platte Pour plaque nervurée • Para plancha acanalada					79,00
Griglia per pesce • Grill for fish • Fischrost • Grille pour poisson • Rejilla para pescado						
 2009144	Per • For • Für • Pour • Para: LTG6700					163,00
2009356	Per • For • Für • Pour • Para: LTG8700					260,00
Griglia per carne • Grill for meat • Fleischrost • Grille pour viande • Rejilla para carne						
 2009142	Per • For • Für • Pour • Para: LTG6700					177,00
2011037	Per • For • Für • Pour • Para: LTG8700					273,00
Griglia ½ carne ½ pesce • Grill ½ meat ½ fish • ½Fleisch ½Fischrost Grille ½ viande ½ poisson • Rejilla ½ carne ½ pescado						
 2012437	Per • For • Für • Pour • Para: LTG8700					363,00
Lava vulcanica • Lava rock • Lavastein • Lave volcanique • Lava volcánica						
 7090123	Confezione • Bag • Packung • Paquet • Paquete: 7kg					39,00
Piano polietilene • Polyethylene surface • Polyäthylenbrett • Plan en polyéthylène • Piano de polietileno						
 2009213	394x526x20h Per • For • Für • Pour • Para: LEN4700					145,00
2009223	594x526x20h Per • For • Für • Pour • Para: LEN6700					198,00

unika700

unika700

PPC PRODOTTI PRONTA CONSEGNA

I prodotti contrassegnati con **PPC** sono disponibili alla spedizione in meno di 24h. • Products marked with **PPC** are available for shipment in less than 24 hours. • Mit **PPC** gekennzeichnete Produkte sind in weniger als 24 Stunden versandbereit. • Les produits marqués avec **PPC** sont disponibles pour l'expédition en moins de 24 heures. • Los productos marcados con **PPC** están disponibles para su envío en menos de 24 horas.



CPG726

CUOCIPASTA A GAS
GAS PASTA COOKER
GAS NUDELKOCHER
CUISSIÈURS À PÂTE À GAZ
CUECE-PASTAS GAS

CPE726

CUOCIPASTA ELETTRICO
ELECTRIC PASTA COOKER
ELEKTRO NUDELKOCHER
CUISSIÈURS À PÂTE ÉLECTRIQUES
CUECE-PASTAS ELÉTRICOS

CG740G / ECG740G

CUCINE GAS
GAS RANGES
GASHERDE
FORNEAUX GAZ
COCINA A GAS

FG7117T (17 LT)

FG7217T (17+17LT)

FG7215T (13+13 LT)

FRIGGITRICI GAS
GAS DEEP FAT FRYERS
GAS FRITEUSEN
FRITEUSES GAZ
FREIDORA A GAS

GIORIK

INNOVATIVE COOKING EQUIPMENT SINCE 1963

CODICE Code Kode Code Codigo	 (A x B x C) mm	VOL./PESO Vol./Weight Vol./Gewicht Vol./Poids Vol./Pesos m ³ /kg	GAS kW	VAC 230-1N 50/60 Hz kW	VAC 400-3N 50/60 Hz kW	PREZZO Price Preis Prix Precio €
--	---	--	-----------	---------------------------------	---------------------------------	---

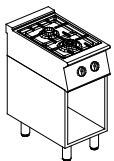
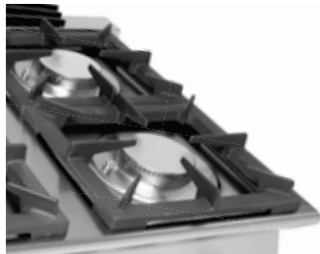

 **ECG720G** 400x700x900 0,5/50 9,5 **1.353,00**

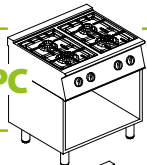

PPC

 **ECG740G** 800x700x900 0,9/80 19 **2.116,00**

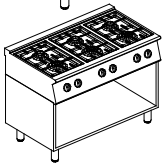

 **ECG760G** 1200x700x900 1,3/110 28,5 **3.030,00**

Fuochi su forno • Burners on oven • Flammen mit Ofen • Feux vifs sur four • Cocinas sobre horno



 **ECG740F** 800x700x900 0,9/140 27 **3.237,00**



ECG740E 800x700x900 0,9/140 19 6,2 **3.674,00**

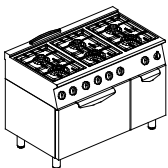

 **ECG760F** 1200x700x900 1,3/210 36,5 **4.319,00**



ECG760E 1200x700x900 1,3/210 28,5 6,2 **4.640,00**

Fuochi su maxi forno • Burners on maxi oven • Flammen mit maxi Ofen
Feux vifs sur four maxi • Cocinas sobre maxi horno

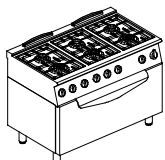

 **ECG760H** 1200x700x900 1,3/210 38,5 **4.563,00**



ECG76EH 1200x700x900 1,3/210 28,5 9 **4.942,00**

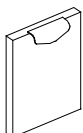

Porte • Doors • Flügeltüren • Portes • Puertas

2016437 **156,00**













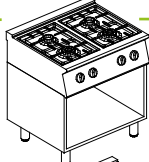

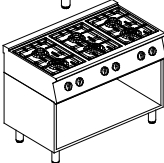

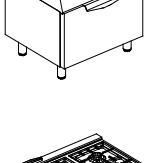

CUCINE A GAS A GIORNO E SU FORNO

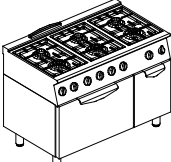
unika700

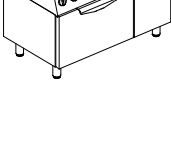
GAS RANGES WITH AND WITHOUT OVEN • GASHERDE MIT UND OHNE BACKOFEN
FORNEAUX GAZ SANS ET AVEC FOUR • COCINAS A GAS

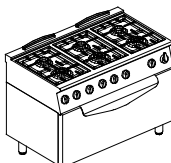
CODICE		VOL./PESO	GAS	VAC	VAC	PREZZO
Code		Vol./Weight		230-1N	400-3N	Price
Kode		Vol./Gewicht		50/60 Hz	50/60 Hz	Preis
Code		Vol./Poids				Prix
Codigo		Vol./Pesos				Precio
	(A x B x C) mm	m ³ /kg	kW	kW	kW	€

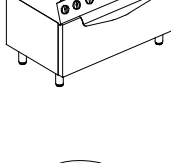

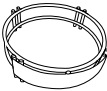
	 CG720G	400x700x900	0,5/50	12		1.674,00	
PPC 	 CG740G	800x700x900	0,9/80	24		2.654,00	
	 CG760G	1200x700x900	1,3/110	36		3.698,00	
Fuochi su forno • Burners on oven • Flammen mit Ofen • Feux vifs sur four • Cocinas sobre horno							
	 CG740F	800x700x900	0,9/140	32		3.869,00	
	 CG740E	800x700x900	0,9/140	24	6,2	4.119,00	
	 CG760F	1200x700x900	1,3/180	44		5.298,00	
	 CG760E	1200x700x900	1,3/180	36	6,2	5.563,00	
Fuochi su maxi forno • Burners on maxi oven • Flammen mit maxi Ofen Feux vifs sur four maxi • Cocinas sobre maxi horno							
	 CG760H	1200x700x900	1,3/210	46		5.354,00	
	 CG76EH	1200x700x900	1,3/210	36	9	5.823,00	
	Riduzione pentole per wok • Wok stand • Wokaufsatz für Gasherde • Réduction grilles pour wok Reductor fogones para wok					2026728	822,00

unika700

LineaBase 700 CONFIGURAZIONE BRUCIATORI

CONFIGURATION BURNERS • KONFIGURATION BRENNER
CONFIGURATION BRÛLEURS • CONFIGURACION DE QUEMADORES

STANDARD

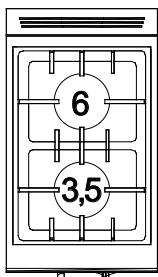

9,5 kW

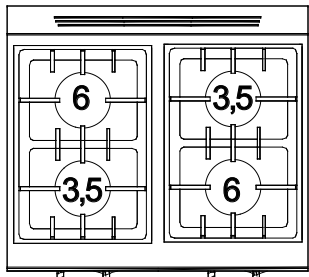

19 kW

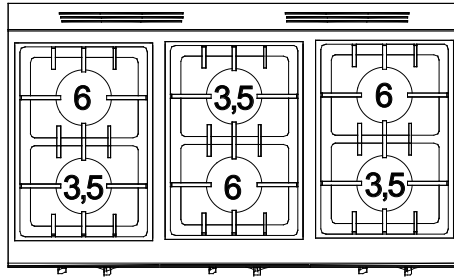

28,5 kW

unika700 CONFIGURAZIONE BRUCIATORI

CONFIGURATION BURNERS • KONFIGURATION BRENNER
CONFIGURATION BRÛLEURS • CONFIGURACION DE QUEMADORES

STANDARD

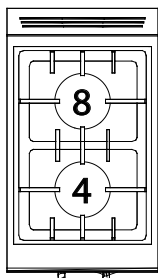

12 kW

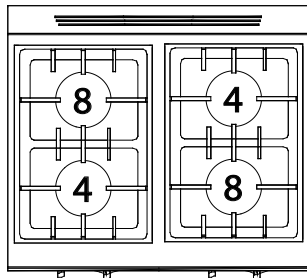

24 kW

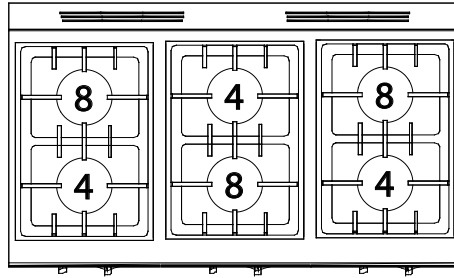

36 kW

Extra prezzo per configurazioni speciali

Extra price for special configurations • Extra Preis für Sonderkonfigurationen

Extra prix pour configurations spéciales • Extra precio para configuraciones especiales

16 kW

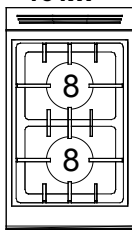

+90,00 €

28 kW

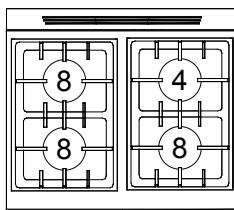

+90,00 €

32 kW

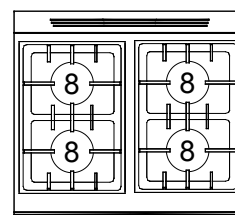

+181,00 €

40 kW

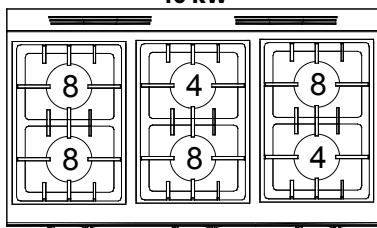

+90,00 €

48 kW

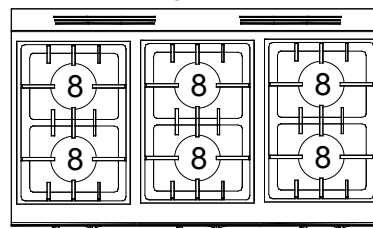

+269,00 €

CUCINE A GAS SU FORNO CON TUTTAPIASTRA

unika700

GAS RANGES WITH OVEN AND SOLID TOPS • GASHERDE MIT BACKOFEN UND GLÜHPLATTENHERDE
 FORNEAUX GAZ AVEC FOUR ET COUP DE FEU • COCINAS A GAS CON HORNO Y PLACAS RADIANTES

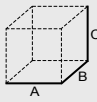
CODICE		VOL./PESO	GAS	VAC	VAC	PREZZO
Code		Vol./Weight		230-1N	400-3N	Price
Kode		Vol./Gewicht		50/60 Hz	50/60 Hz	Preis
Code		Vol./Poids				Prix
Codigo		Vol./Pesos				Precio
	(A x B x C) mm	m ³ /kg	kW	kW	kW	€



2 fuochi sx con piastroncino su forno a gas • 2 burners left with hot plate on top of gas oven
 2 Kochstellen li mit Platte und Gas-Backofen • 2 feux G avec plaque sur four à gaz
 2 fuegos izq con placa sobre horno de gas

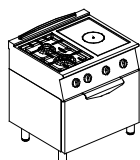

TG74FTL 800x700x900 0,9/100 26 **4.931,00**

2 fuochi dx con piastroncino su forno a gas • 2 burners right with hot plate on top of gas oven
 2 Kochstellen re mit Platte und Gas-Backofen • 2 feux D avec plaque sur four à gaz
 2 fuegos dcha con placa sobre horno de gas

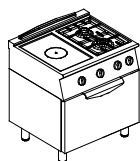

TG74FTR 800x700x900 0,9/100 26 **4.931,00**

4 fuochi sx/dx con piastroncino centrale su forno a gas • 4 burners left/right with central hot plate on top of gas oven
 4 Kochstellen li/re mit mittiger Platte und Gas-Backofen • 4 feux G/D avec plaque centrale sur four à gaz
 4 fuegos izq/dcha con placa central sobre horno de gas

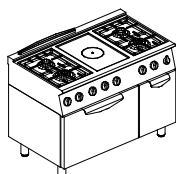

TG76FTC 1200x700x900 1,3/210 38 **6.107,00**

2 fuochi sx con piastroncino su forno a gas • 2 burners left with hot plate on top of gas oven
 2 Kochstellen li mit Platte und Gas-Backofen • 2 feux G avec plaque sur four à gaz
 2 fuegos izq con placa sobre horno de gas

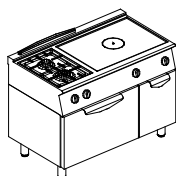

TG76FTL 1200x700x900 2,3/170 32 **6.169,00**

2 fuochi dx con piastroncino su forno a gas • 2 burners right with hot plate on top of gas oven
 2 Kochstellen re mit Platte und Gas-Backofen • 2 feux D avec plaque sur four à gaz
 2 fuegos dcha con placa sobre horno de gas

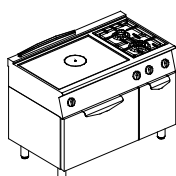

TG76FTR 1200x700x900 2,3/170 32 **6.169,00**

unika700

GAS RANGES WITH SOLID TOPS • GASHERDE MIT GLÜHPLATTENHERDE
 FORNEAUX GAZ AVEC COUP DE FEU • COCINAS A GAS CON PLACAS RADIANTES

CODICE		VOL./PESO	GAS	VAC	VAC	PREZZO
Code		Vol./Weight		230-1N	400-3N	Price
Kode		Vol./Gewicht		50/60 Hz	50/60 Hz	Preis
Code		Vol./Poids				Prix
Codigo		Vol./Pesos				Precio
	(A x B x C) mm	m ³ /kg	kW	kW	kW	€



2 fuochi sx con piastroncino • 2 burners left with hot plate
 2 Kochstellen li mit Platte • 2 feux G avec plaque
 2 fuegos izq con placa



TG74GTL 800x700x900 0,9/100 18 **3.885,00**

2 fuochi dx con piastroncino • 2 burners right with hot plate
 2 Kochstellen re mit Platte • 2 feux D avec plaque
 2 fuegos dcha con placa

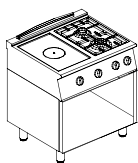

TG74GTR 800x700x900 0,9/100 26 **3.885,00**

4 fuochi sx/dx con piastroncino centrale • 4 burners left/right with central hot plate
 4 Kochstellen li/re mit mittiger Platte • 4 feux G/D avec plaque centrale
 4 fuegos izq/dcha con placa central

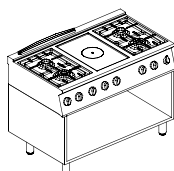

TG76GTC 1200x700x900 1,3/210 30 **5.021,00**

2 fuochi sx con piastroncino • 2 burners left with hot plate
 2 Kochstellen li mit Platte • 2 feux G avec plaque
 2 fuegos izq con placa

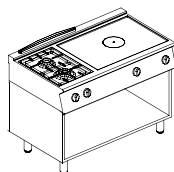

TG76GTL 1200x700x900 2,3/170 24 **4.857,00**

2 fuochi dx con piastroncino • 2 burners right with hot plate
 2 Kochstellen re mit Platte • 2 feux D avec plaque
 2 fuegos dcha con placa

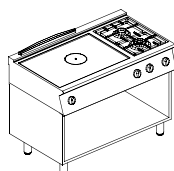

TG76GTR 1200x700x900 2,3/170 24 **4.857,00**

CUCINE TUTTAPIASTRA

unika700

SOLID TOPS • GLÜHPLATTENHERDE
CUISINIÈRES COUP DE FEU • PLACAS RADIANTES

CODICE Code Kode Code Codigo	 (A x B x C) mm	VOL./PESO Vol./Weight Vol./Gewicht Vol./Poids Vol./Pesos m ³ /kg	GAS kW	VAC 230-1N 50/60 Hz kW	VAC 400-3N 50/60 Hz kW	PREZZO Price Preis Prix Precio €
--	---	--	-----------	---------------------------------	---------------------------------	---

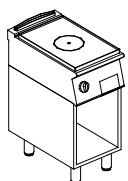

 **TG720G** 400x700x900 0,5/85 6 **2.518,00**

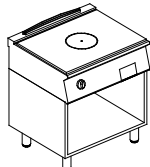

 **TG740G** 800x700x900 0,9/11 12 **3.072,00**

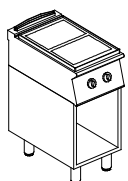

 **TE720G** 400x700x900 0,5/85 4 **3.072,00**

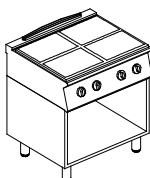

 **TE740G** 800x700x900 0,9/110 10 **4.445,00**

Forno gas • Gas oven • Gas Backofen • Four à gaz • Horno a gas

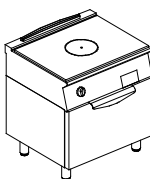

 **TG740F** 800x700x900 0,9/130 20 **4.547,00**

Forno elettrico • Electric oven • Elektro Backofen • Four électrique • Horno eléctrico

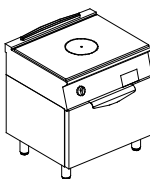

 **TG740E** 800x700x900 0,9/130 12 6,2 **4.971,00**

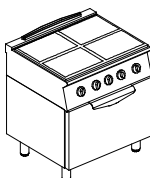

 **TE740E** 800x700x900 0,9/150 16,2 **6.412,00**

ACCESSORI

ACCESSORIES • ZUBEHÖR • ACCESSOIRES • ACCESORIOS



Leverino • Lever • Eisen • Petit levier • Palanca

2019661 **66,00**

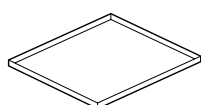

Teglia forno GN 2/1 • Baking tin GN 2/1 • Backblech GN 2/1 • Plaque four GN 2/1 • Bandeja horno GN 2/1

2022220 650x530x40 **63,00**

ELECTRIC RANGE WITH SQUARE PLATES • ELEKTROHERDE MIT VIERECKIGEN GUSSPLATTEN
 FORNEAUX ÉLECTRIQUES AVEC PLAQUES CARRÉES • COCINAS ELÉCTRICAS CON PLANCHAS CUADRADAS

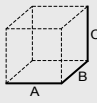
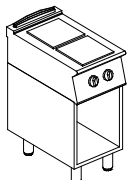
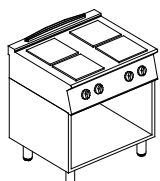
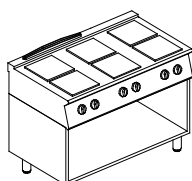
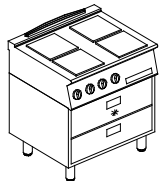
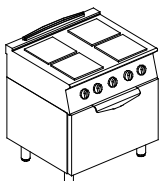
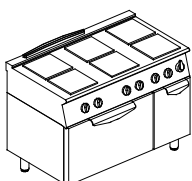
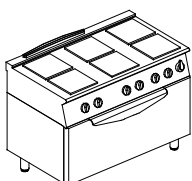
CODICE Code Kode Code Código		VOL./PESO Vol./Weight Vol./Gewicht Vol./Poids Vol./Pesos	GAS	VAC 230-1N 50/60 Hz	VAC 400-3N 50/60 Hz	PREZZO Price Preis Prix Precio
	CE72QG	400x700x900 2x(220x220)	0,6/60		5,2	2.000,00
	CE74QG	800x700x900 4x(220x220)	0,9/90		10,4	3.202,00
	CE76QG	1200x700x900 6x(220x220)	1,3/100		15,6	4.383,00
Mantenitore • Holding • Warmhaltegeräte • Les fours de maintien • Mantenedores						
	CE74QGMC	800x700x900 4x(220x220)	0,9/100	0,9 *	10,4 **	6.083,00
Forno elettrico • Electric oven • Elektro Backofen • Four électrique • Horno eléctrico						
	CE74QE	800x700x900 4x(220x220)	0,9/130		16,6	4.876,00
	CE76QE	1200x700x900 6x(220x220)	1,3/160		21,8	6.348,00
	CE76QH	1200x700x900 6x(220x220)	1,3/160		24,6	6.799,00

* Potenza mantenitore • Holding power • Maintainer Macht • Puissance mainteneur • Potencia mantenedor
 ** Potenza piastre • Plates Power • Kochplatten Macht • Puissance de plaques de cuisson • Potencia placas

CUCINE ELETTRICHE CON PIASTRE ROTONDE

unika700

ELECTRIC RANGE WITH ROUND PLATES • ELEKTROHERDE MIT RUNDEN PLATTEN

FORNEAUX ÉLECTRIQUES AVEC PLAQUES ARRONDIES • COCINAS ELÉCTRICAS CON PLANCHAS REDONDAS

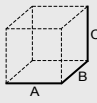
CODICE Code Kode Code Codigo	 (A x B x C) mm	VOL./PESO Vol./Weight Vol./Gewicht Vol./Poids Vol./Pesos m ³ /kg	GAS kW	VAC 230-1N 50/60 Hz kW	VAC 400-3N 50/60 Hz kW	PREZZO Price Preis Prix Precio €
--	---	--	-----------	---------------------------------	---------------------------------	---

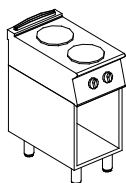

⚡ **CE72TG** 400x700x900
2x ø220 0,5/60 5,2 **1.436,00**

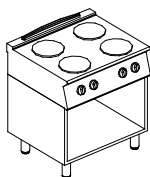

⚡ **CE74TG** 800x700x900
4x ø220 0,9/90 10,4 **1.932,00**

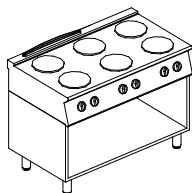

⚡ **CE76TG** 1200x700x900
6x ø220 1,3/100 15,6 **2.274,00**

Forno elettrico • Electric oven • Elektro Backofen • Four électrique • Horno eléctrico

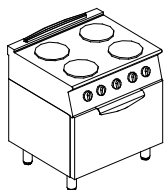

⚡ **CE74TE** 800x700x900
4x ø220 0,9/130 16,6 **3.578,00**

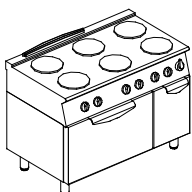

⚡ **CE76TE** 1200x700x900
6x ø220 1,3/160 21,8 **4.884,00**

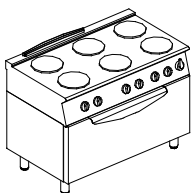

⚡ **CE76TH** 1200x700x900
6x ø220 1,3/160 24,6 **5.023,00**

unika700

unika700 CUCINE VETROCERAMICA

RANGES CERAMIC GLASS • HERDE GLASKERAMIK • PLAQUES DE CUISSON EN VITROCÉRAMIQUE
COCINAS VETROCERAMICA

CODICE Code Kode Code Codigo	 (A x B x C) mm	VOL./PESO Vol./Weight Vol./Gewicht Vol./Poids Vol./Pesos m ³ /kg	GAS kW	VAC 230-1N 50/60 Hz kW	VAC 400-3N 50/60 Hz kW	PREZZO Price Preis Prix Precio €
--	---	--	-----------	---------------------------------	---------------------------------	---

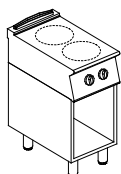

⚡ **CV720G** 400x700x900
2x ø230 0,5/60 4,2 **1.947,00**

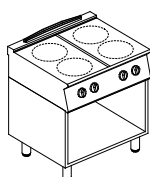

⚡ **CV740G** 800x700x900
4x ø230 0,9/90 8,4 **3.159,00**

Forno elettrico • Electric oven • Elektro Backofen • Four électrique • Horno eléctrico

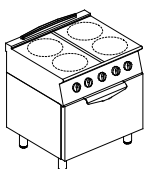

⚡ **CV740E** 800x700x900
4x ø230 0,9/130 14,4 **4.905,00**

CUCINA A INDUZIONE

unika700

INDUCTION RANGES • INDUKTIONSHERDE • PLAQUES DE CUISSON À INDUCTION
COCINAS ELECTRICAS A INDUCCIÓN

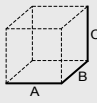
CODICE Code Kode Code Codigo	 (A x B x C) mm	VOL./PESO Vol./Weight Vol./Gewicht Vol./Poids Vol./Pesos m ³ /kg	GAS kW	VAC 230-1N 50/60 Hz kW	VAC 400-3N 50/60 Hz kW	PREZZO Price Preis Prix Precio €
--	---	--	-----------	---------------------------------	---------------------------------	---

Piastre induzione • Induction rings • Induktionsplatten • Foyers à induction • Placas de induccion

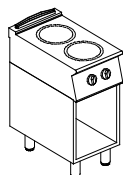

 CI720G	400x700x900 2x ø230	0,5/70			7	8.114,00
---	------------------------	--------	--	--	---	-----------------

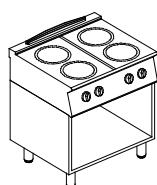

 CI740G	800x700x900 4x ø230	0,9/100			14	13.102,00
---	------------------------	---------	--	--	----	------------------

Wok induzione • Induction wok • Induktion-Wok • Wok à induction • Placas de induccion Wok

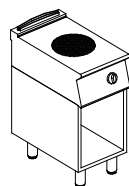

 CW720G	400x700x900 1x ø300	0,5/85			5	7.309,00
---	------------------------	--------	--	--	---	-----------------

ACCESSORI

ACCESSORIES • ZUBEHÖR • ACCESSOIRES • ACCESORIOS



Pentola per wok • Pan for wok • Topf für Wok • Casserolle pour wok • Olla para wok

5920010	Dim. ø360x102H mm					403,00
----------------	-------------------	--	--	--	--	---------------

unika700

MULTI COOKING BRATT PANS • ELEKTRO MULTI-BRÄTER
MULTI-SAUTEUSE • SARTEN MULTIPLIO

CODICE Code Kode Code Codigo	 (A x B x C) mm	VOL./PESO Vol./Weight Vol./Gewicht Vol./Poids Vol./Pesos m³/kg	VAC 230-1N 50/60 Hz kW	VAC 400-3N 50/60 Hz kW	CAPACITA' Capacity Inhalt Capacité Capacidad Lt.	PREZZO Price Preis Prix Precio €
---	--	---	---	---	---	---



CM720G

400x700x900
GN 1/1

0,5/90

230-1N
50/60 Hz

5,1

12

3.354,00

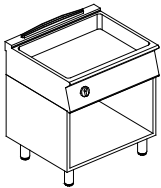

CM740G

800x700x900
GN 2/1

0,9/130

230-1N
50/60 Hz

10,2

24

4.756,00

SCALDAPATATE

CHIPS SCUTTLES • POMMES FRITES-WÄRMER • BAC DE SALAGE • CALIENTAPATATAS

CODICE Code Kode Code Codigo	 (A x B x C) mm	VOL./PESO Vol./Weight Vol./Gewicht Vol./Poids Vol./Pesos m³/kg	VAC 230-1N 50/60 Hz kW	VAC 400-3N 50/60 Hz kW	CAPACITA' Capacity Inhalt Capacité Capacidad Lt.	PREZZO Price Preis Prix Precio €
---	--	---	---	---	---	---

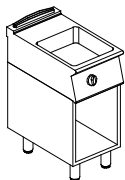

SP720G

400x700x900
GN 2/3

0,5/55

1,38

1.758,00

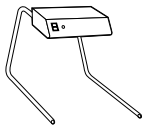

LSR4911

400x390x410

0,12/13

0,75

748,00

FRY TOP A GAS

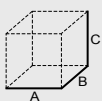

unika700

GAS GRIDDLE PLATES • GAS-GRILLPLATTEN
GRILLADES GAZ • FRY-TOP A GAS

CODICE Code Kode Code Codigo		VOL./PESO Vol./Weight Vol./Gewicht Vol./Poids Vol./Pesos	GAS	VAC 230-1N 50/60 Hz	VAC 400-3N 50/60 Hz	PREZZO Price Preis Prix Precio
	(A x B x C) mm	m ³ /kg	kW	kW	kW	€

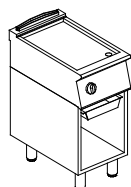

Liscio • Smooth • Glatt • Lisse • Liso



 FLG72GF	400x700x900	0,5/75	7			1.906,00
<i>Non disponibile per la Comunità Europea • Not available for UE market</i>						
 FLG72GCRX	400x700x900	0,5/75	7			2.282,00
Termostato • Thermostated • Thermostate • Thermostatisiert • Termostatizado						

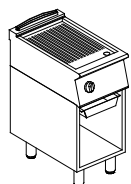

Rigato • Ribbed • Gerillt • Nervuré • Acanalado



 FRG72GF	400x700x900	0,5/75	7			2.262,00
<i>Non disponibile per la Comunità Europea • Not available for UE market</i>						
 FRG72GCRX	400x700x900	0,5/75	7			2.586,00
Termostato • Thermostated • Thermostate • Thermostatisiert • Termostatizado						

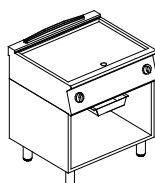

Liscio • Smooth • Glatt • Lisse • Liso



 FLG741GF	800x700x900	0,9/120	14			2.916,00
<i>Non disponibile per la Comunità Europea • Not available for UE market</i>						
 FLG741GCRX	800x700x900	0,9/120	14			3.494,00
Termostato • Thermostated • Thermostate • Thermostatisiert • Termostatizado						

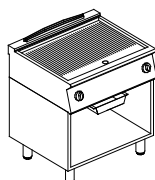

Rigato • Ribbed • Gerillt • Nervuré • Acanalado

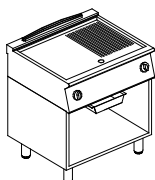

 FRG741GF	800x700x900	0,9/120	14			3.165,00
<i>Non disponibile per la Comunità Europea • Not available for UE market</i>						
 FRG741GCRX	800x700x900	0,9/120	14			4.066,00
Termostato • Thermostated • Thermostate • Thermostatisiert • Termostatizado						

Liscio-Rigato • Smooth-Ribbed • Glatt-Gerillt • Lisse-Nervuré • Liso-Acanalado



 FMG741GF	800x700x900	0,9/120	14			3.084,00
<i>Non disponibile per la Comunità Europea • Not available for UE market</i>						
 FMG741GCRX	800x700x900	0,9/120	14			3.771,00
Termostato • Thermostated • Thermostate • Thermostatisiert • Termostatizado						

F Piastra in ferro • Mild iron plate • Platte aus Eisen • Plaque en fer • Placa de hierro
Non disponibile per la comunità Europea • Not available for UE market • Nicht erhältlich für die Europäische Gemeinschaft • Non disponible pour la Communauté européenne • No disponible para la Comunidad europea

CRX Piastra in acciaio spessore 15 mm con finitura cromata satinata
Conforme al regolamento CE 1935/2004 riguardante materiali e oggetti a contatto con gli alimenti. Il materiale è antiaderente e garantisce resistenza alla corrosione e ai graffi. • Steel Chrome-plated satin finish, 15 mm thickness. In compliance with UE Regulation 1935/2004 on materials and articles in contact with food. The material is non-stick and guarantees resistance to corrosion and scratches. • Stahl Verchromt satiniert, 15 mm dick. • Acier chromé satiné, épaisseur 15 mm. • Acero Cromado satinado, 15 mm de espesor.



unika700 FRY TOP ELETTRICI

ELECTRIC GRIDDLE PLATES • ELEKTRO-GRILLPLATTEN
GRILLADES ÉLECTRIQUES • FRY-TOP ELÉCTRICOS

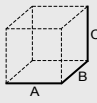
CODICE Code Kode Code Codigo	 (A x B x C) mm	VOL./PESO Vol./Weight Vol./Gewicht Vol./Poids Vol./Pesos m³/kg	GAS kW	VAC 230-1N 50/60 Hz kW	VAC 400-3N 50/60 Hz kW	PREZZO Price Preis Prix Precio €
--	---	---	-----------	---------------------------------	---------------------------------	---

Liscio • Smooth • Glatt • Lisse • Liso

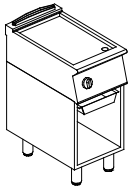

FLE72GF	400x700x900	0,5/75			6	2.056,00
----------------	-------------	--------	--	--	---	-----------------

Non disponibile per la Comunità Europea • Not available for UE market

FLE72GCRX	400x700x900	0,5/75			6	2.282,00
------------------	-------------	--------	--	--	---	-----------------

Rigato • Ribbed • Gerillt • Nervuré • Acanalado

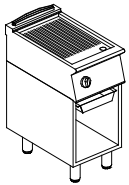

FRE72GF	400x700x900	0,5/75			6	2.159,00
----------------	-------------	--------	--	--	---	-----------------

Non disponibile per la Comunità Europea • Not available for UE market

FRE72GCRX	400x700x900	0,5/75			6	2.401,00
------------------	-------------	--------	--	--	---	-----------------

Liscio • Smooth • Glatt • Lisse • Liso

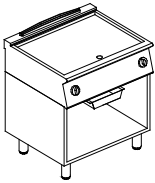

FLE741GF	800x700x900	0,9/120			12	3.144,00
-----------------	-------------	---------	--	--	----	-----------------

Non disponibile per la Comunità Europea • Not available for UE market

FLE741GCRX	800x700x900	0,9/120			12	3.486,00
-------------------	-------------	---------	--	--	----	-----------------

Rigato • Ribbed • Gerillt • Nervuré • Acanalado

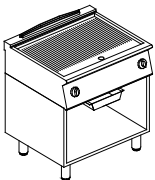

FRE741GF	800x700x900	0,9/120			12	3.384,00
-----------------	-------------	---------	--	--	----	-----------------

Non disponibile per la Comunità Europea • Not available for UE market

FRE741GCRX	800x700x900	0,9/120			12	3.801,00
-------------------	-------------	---------	--	--	----	-----------------

Liscio-Rigato • Smooth-Ribbed • Glatt-Gerillt • Lisse-Nervuré • Liso-Acanalado

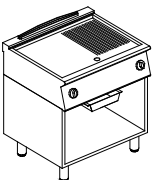

FME741GF	800x700x900	0,9/120			12	3.195,00
-----------------	-------------	---------	--	--	----	-----------------

Non disponibile per la Comunità Europea • Not available for UE market

FME741GCRX	800x700x900	0,9/120			12	3.686,00
-------------------	-------------	---------	--	--	----	-----------------

F Piastra in ferro • Mild iron plate • Platte aus Eisen • Plaque en fer • Placa de hierro
Non disponibile per la comunità Europea • Not available for UE market • Nicht erhältlich für die Europäische Gemeinschaft • Non disponible pour la Communauté européenne • No disponible para la Comunidad europea

CRX Piastra in acciaio spessore 15 mm con finitura cromata satinata
Conforme al regolamento CE 1935/2004 riguardante materiali e oggetti a contatto con gli alimenti. Il materiale è antiaderente e garantisce resistenza alla corrosione e ai graffi. • Steel Chrome-plated satin finish, 15 mm thickness. In compliance with UE Regulation 1935/2004 on materials and articles in contact with food. The material is non-stick and guarantees resistance to corrosion and scratches. • Stahl Verchromt satiniert, 15 mm dick. • Acier chromé satiné, épaisseur 15 mm. • Acero Cromado satinado, 15 mm de espesor.

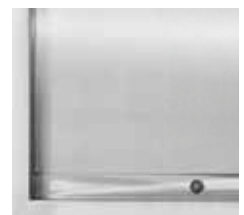

AQUA-GRILL A GAS

unika700

GAS STEAMGRILL • DAMPF GRILL, GAS AUSFÜHRUNG • GRILLE VAPEUR À GAZ
VAPOR BARBACOA DE GAS

CODICE Code Kode Code Codigo	 (A x B x C) mm	VOL./PESO Vol./Weight Vol./Gewicht Vol./Poids Vol./Pesos m ³ /kg	GAS kW	VAC 230-1N 50/60 Hz kW	VAC 400-3N 50/60 Hz kW	PREZZO Price Preis Prix Precio €
--	---	--	-----------	---------------------------------	---------------------------------	---

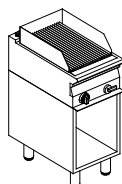

 **GL72GV** 400x700x900 0,5/75 8,5 **2.728,00**

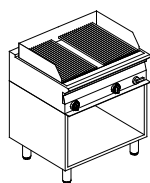

 **GL74GV** 800x700x900 0,9/100 17 **4.029,00**

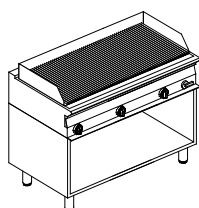

 **GL76GV** 1200x700x900 1,3/110 25,5 **4.958,00**

AQUA-GRILL ELETTRICI

ELECTRIC STEAMGRILL • DAMPF GRILL, ELEKTRO AUSFÜHRUNG • GRILLE VAPEUR ÉLECTRIQUE
VAPOR BARBACOA ELÉCTRICO

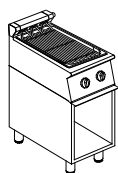

 **GL72GE** 400x700x900 0,5/75 4 **3.354,00**

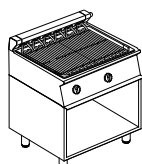

 **GL74GE** 800x700x900 0,9/80 8 **4.356,00**

unika700

LAVA ROCK GRILLS • LAVASTEINGRILLS
GRILLES À PIERRE VOLCANIQUE • BARBACOA DE PIEDRA LÁVICA

CODICE		VOL./PESO	GAS	VAC	VAC	PREZZO
Code Kode Code Codigo		Vol./Weight Vol./Gewicht Vol./Poids Vol./Pesos		230-1N 50/60 Hz	400-3N 50/60 Hz	Price Preis Prix Precio
	(A x B x C) mm	m ³ /kg	kW	kW	kW	€

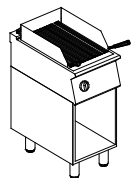

Griglia per carne • Grill for meat • Fleischrost • Grille pour viande • Rejilla para carne

 **GL720GC** 400x700x900 0,5/75 10 **2.418,00**

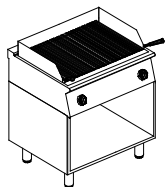

 **GL740GC** 800x700x900 0,9/100 20 **3.574,00**

ACCESSORI

ACCESSORIES • ZUBEHÖR • ACCESSOIRES • ACCESORIOS

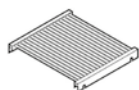

Griglia per pesce • Grill for fish • Fischrost • Grille pour poisson • Rejilla para pescado

2009337 Per • For • Für • Pour • Para: GL720GC **243,00**

2009356 Per • For • Für • Pour • Para: GL740GC **260,00**



Griglia per carne • Grill for meat • Fleischrost • Grille pour viande • Rejilla para carne

2011036 Per • For • Für • Pour • Para: GL720GC **168,00**

2011037 Per • For • Für • Pour • Para: GL740GC **273,00**



Griglia ½ carne ½ pesce • Grill ½ meat ½ fish • ½Fleisch ½Fischrost
Grille ½ viande ½ poisson • Rejilla ½ carne ½ pescado

2012437 Per • For • Für • Pour • Para: GL740GC **363,00**

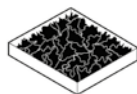

Lava vulcanica • Lava rock • Lavastein • Lave volcanique • Lava volcànica

7090123 Confezione • Bag • Packung • Emballage • Envase: **7kg** **39,00**

BAGNO MARIA

unika700

BAIN MARIES • BAIN-MARIES • BAIN-MARIE • BAÑO MARÍA

CODICE Code Kode Code Codigo	 (A x B x C) mm	VOL./PESO Vol./Weight Vol./Gewicht Vol./Poids Vol./Pesos m³/kg	GAS kW	VAC 230-1N 50/60 Hz kW	VAC 400-3N 50/60 Hz kW	PREZZO Price Preis Prix Precio €
--	---	---	-----------	---------------------------------	---------------------------------	---

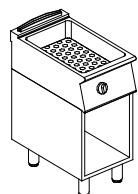

 BM720E GN 1/1	400x700x900	0,5/40		1,1		1.863,00
---	-------------	--------	--	-----	--	-----------------



 BM740E GN 2/1	800x700x900	0,9/55		2,2		2.371,00
---	-------------	--------	--	-----	--	-----------------

I prezzi dei bagnomaria **NON COMPRENDONO I CESTELLI** • The **BASKETS ARE NOT INCLUDED** in the price of bain maries • Die Preise der Bain Maries **ENTHALTEN KEINE KÖRBE** • Les prix des bain marie **NE COMPRENNENT PAS LES PANIERS** • Los precios de los baño maría **NO INCLUYEN LOS CESTOS**.

ACCESSORI

ACCESSORIES • ZUBEHÖR • ACCESSOIRES • ACCESORIOS

Bacinelle • Basins • Behälter • Bacs • Recipientes

2103135	GN 1/4 H150	55,00
2103142	GN 1/3 H150	51,00
2103080	GN 1/2 H150	72,00
2103107	GN 2/3 H150	89,00
2103134	GN 1/1 H150	108,00
2103144	GN 2/1 H150	184,00



Coperchi • Lids • Deckel • Couvercles • Tapas

2103202	Per • For • Für • Pour • Para: GN 1/4	23,00
2103203	Per • For • Für • Pour • Para: GN 1/3	21,00
2103077	Per • For • Für • Pour • Para: GN 1/2	21,00
2103201	Per • For • Für • Pour • Para: GN 2/3	39,00
2103106	Per • For • Für • Pour • Para: GN 1/1	62,00
2103145	Per • For • Für • Pour • Para: GN 2/1*	55,00



Traversino per bagno maria • Support for bain marie • Querstrebe für Bain-Marie
Traverse pour bain-marie • Larguero para baño maría





2014924	327x25	10,00
2014925	532x25	11,00

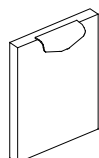

Porte • Doors • Flügeltüren • Portes • Puertas

2016437		156,00
----------------	--	---------------

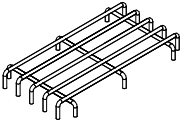
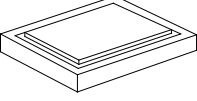
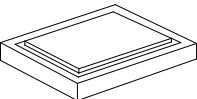
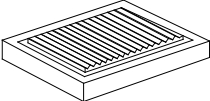
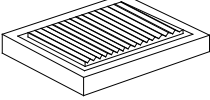

	CODICE Code Kode Code Codigo	mm	PREZZO Price Preis Prix Precio
			€
	2016213	395x285	127,00
Griglia in ghisa vetrificata monofuoco • Single-burner vitrified cast iron pan rest • Einflammen-Topfträger aus verglastem Gusseisen • Grille en fonte vitrifiée monofeu • Rejilla de hierro fundido vitrificada para quemador único			
Non ordinabile per Linea Base700 • Not suitable for Linea Base 700 • Nicht geeignet für Linea Base 700 • Pas adapté pour Linea Base 700 • No puedes pedir por Linea Base 700			
	2021106	335x300	69,00
Griglia in ghisa monofuoco per Linea Base • Single-burner cast iron pan rest for Base Line • Einflammen-Topfträger für Basis-Linie • Grille en fonte monofeu pour la Ligne Base • Rejilla de hierro fundido con quemador único para la Línea Base			
	2020589		253,00
Griglia in tondino • Rounded metal grill • Rundeisengitter • Grille en fil rond • Parrilla de varillas			
Non ordinabile per Linea Base700 • Not suitable for Linea Base 700 • Nicht geeignet für Linea Base 700 • Pas adapté pour Linea Base 700 • No puedes pedir por Linea Base 700			
	2016443	390x280	168,00
Piastra liscia in Fe510 • Smooth Fe510 plate • Fe510 Platte glatt Plaque lisse en Fe510 • Planchar de Fe510			
Non disponibile per la Comunità Europea • Not available for UE market			
	2016443X	390x280	255,00
Piastra liscia in acciaio inossidabile Duplex 2304 • Smooth Duplex 2304 stainless steel plate • Glatte Platte aus rostfreiem Stahl Duplex 2304 • Plaque lisse en acier inoxydable Duplex 2304 • Placa lisa de acero inoxidable Duplex 2304			
	2016444	390x280	184,00
Piastra rigata in Fe510 • Ribbed Fe510 plate • Fe510 Gusseisenplatte gerillt Plaque rajée en Fe510 • Planchar panuradas de Fe510			
Non disponibile per la Comunità Europea • Not available for UE market			
	2016444X	390x280	270,00
Piastra rigata in acciaio inossidabile Duplex 2304 • Ribbed Duplex 2304 stainless steel plate • Gerillte Platte aus rostfreiem Stahl Duplex 2304 • Plaque nervurée en acier inoxydable Duplex 2304 • Placa acanalada de acero inoxidable Duplex 2304			
	2016438	GN 2/1	84,00
Griglie forno in acciaio • Chrome-plated steel grids for oven • Verchromter Stahl Grill Grille four chromée • Revillas cromada			
2016442	930x560	Per forno Maxi • For Maxi Oven • Für Maxi Ofen Pour Four Maxi • Para Horno Maxi	92,00

ACCESSORI PER FRY TOP

unika700

ACCESSORIES FOR FRY TOP • ZUBEHÖR FÜR GRILLPLATTEN • ACCESSOIRES POUR GRILLADES
ACCESORIOS PARA FRY-TOP

CODICE Code Kode Code Codigo		PREZZO Price Preis Prix Precio
	Paraspruzzi • Splashguard • Spritzenschutz • Anti-éclaboussures • Antisalpicaduras	€
	2024855 Per piastra unica 1/2 • For single plate 1/2 • Für Großfeldkochplatte 1/2 • Pour plaque unique 1/2 • Para placa única 1/2	168,00
	2024234 Per piastra unica 1/1 • For single plate 1/1 • Für Großfeldkochplatte 1/1 • Pour plaque unique 1/1 • Para placa única 1/1	189,00
	Raschietti per fry top • Scrapers for fry top • Kratzer für Grillplatten Grattoir four grills • Raspador para fry top	
	7080100 Per piastra liscia • For smooth plate • Für glatte Platte Pour plaque lisse • Para plancha lisa	58,00
	7080101 Per piastra rigata • For ribbed plate • Für gerillte Platte Pour plaque nervurée • Para plancha acanalada	79,00

unika700

GAS AND ELECTRIC PASTA COOKER • ELEKTRO UND GAS NUDELKOCHER
 CUISIÈURS À PÂTE À GAZ ET ÉLECTRIQUES • CUECE-PASTAS GAS Y ELÉCTRICOS

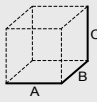
CODICE Code Kode Code Codigo	 (A x B x C) mm	VOL./PESO Vol./Weight Vol./Gewicht Vol./Poids Vol./Pesos	GAS	VAC 400-3N 50/60 Hz	CAPACITA' Capacity Inhalt Capacité Capacidad	PREZZO Price Preis Prix Precio
		m ³ /kg	kW	kW	Lt.	€

■ PPC

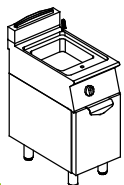

 **CPG726** 400x700x900 0,5/52 10 26 **3.082,00**

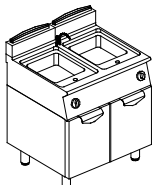

 **CPG746** 800x700x900 0,9/80 20 26 + 26 **5.178,00**

■ PPC

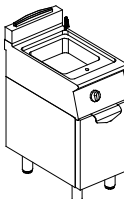

 **CPE726** 400x700x900 0,5/50 6 26 **2.960,00**

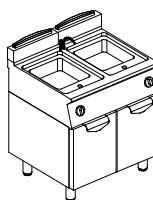

 **CPE746** 800x700x900 0,9/70 12 26 + 26 **4.917,00**

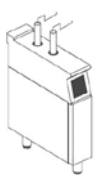

Modulo alzacestelli • Basker lifter • Korbhebersystem
 Module pour le relevege • Modulo levanta cestos automatico

MAC70 150x700x900 **4.009,00**

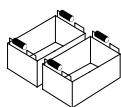

Kit 2 cestelli GNI/3 per MAC70 • Kit 2 baskets GNI/3 for MAC70 • Kit 2 Körbe GNI/3 für MAC70 •
 Kit 2 paniers GNI/3 pour MAC70 • Kit 2 cestos GNI/3 para MAC70

2024513K 290x160x170 **406,00**

I prezzi dei cuocipasta **NON COMPREDONO I CESTELLI** • The **BASKETS ARE NOT INCLUDED** in the price of pasta cookers • Die Preise der Nudelkochern **ENTHALTEN KEINE KÖRBE** • Les prix des cuiseurs a pâtes **NE COMPRENNENT PAS LES PANIERS** • Los precios de los cuecepastas **NO INCLUYEN LOS CESTOS**.

ACCESSORI PER CUOCIPASTA

unika700

ACCESSORIES FOR PASTA BOILERS • NUDELKOCHERZUBEHÖR
ACCESSOIRES POUR CUISEUR À PÂTES • ACCESORIOS PARA CUECE-PASTAS

CODICE	PREZZO
Code	Price
Kode	Preis
Code	Prix
Codigo	Precio
	€

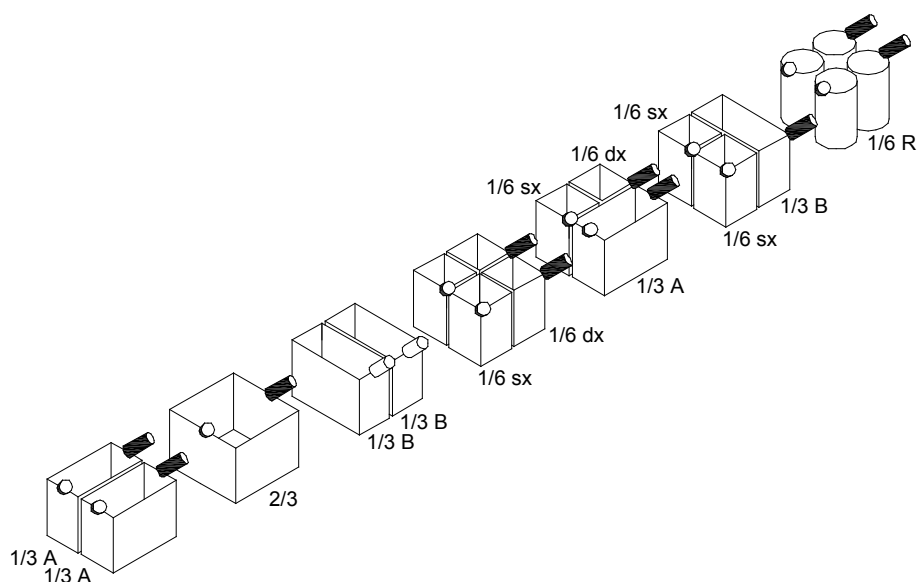

Cestelli • Baskets • Körbe • Paniers • Cestos			
2003075	2/3 GN	mm 298x334x215H	168,00
2003046	1/3 GN (A)	mm 290x160x215H	132,00
2003077	1/3 GN (B)	mm 296x143x215H	137,00
2003045	1/6 GN (dx)	mm 163x143x215H	106,00
2003047	1/6 GN (sx)	mm 163x143x215H	106,00
2003080	1/6 GN (R)	Ø mm 152x215H	100,00

Coperchi per cuocipasta • Lids for pasta cooker • Deckel für Nudelkocher
Couverture pour cuiseurs à pâtes • Tapa para clecepasta

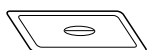



2004151	1 x GN 2/3		39,00
----------------	------------	--	--------------

unika700

unika700 FRIGGITRICI GAS

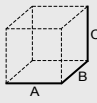
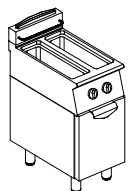
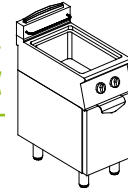
GAS DEEP FAT FRYERS • GAS FRITEUSEN
FRITEUSES GAZ • FREIDORAS A GAS

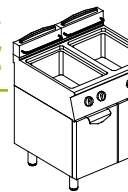
CODICE Code Kode Code Codigo		VOL./PESO Vol./Weight Vol./Gewicht Vol./Poids Vol./Pesos	GAS	VAC 230-1N 50/60 Hz	CAPACITA' Capacity Inhalt Capacité Capacidad	PREZZO Price Preis Prix Precio
 FG7207T	400x700x900	0,5/73	12	0,2	8 + 8	4.135,00
FG7207MT	400x700x900	0,5/73	12	0,2	8 + 8	5.068,00
 FG7113T	400x700x900	0,5/58	11,5	0,1	13	2.821,00
PPC FG7117T	400x700x900	0,5/68	16,5	0,1	17	3.108,00
FG7113MT	400x700x900	0,5/68	11,5	0,1	13	3.500,00
FG7117MT	400x700x900	0,5/68	16,5	0,1	17	3.764,00
 FG7215T	600x700x900	0,6/100	18,8		13 + 13	4.328,00
FG7215MT	600x700x900	0,6/100	18,8	0,2	13 + 13	5.204,00
 FG7213T	800x700x900	0,9/100	23	0,2	13 + 13	4.979,00
PPC FG7217T	800x700x900	0,9/121	33	0,2	17 + 17	5.553,00
FG7213MT	800x700x900	0,9/100	23	0,2	13 + 13	5.895,00
FG7217MT	800x700x900	0,9/121	33	0,2	17 + 17	6.432,00



**ELECTRONIC
MELTING CONTROL**

...M

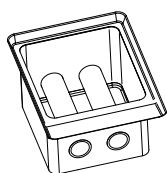

Scambiatori di calore INTERNI alla vasca
INTERNAL heat exchangers
Warmetauschern INNERHALB der Becken
Échangeurs de chaleur INTERNES à la cuve
Intercambiadores de calor ENTRE de la cuba

I prezzi sono **INCLUSIVI DEI CESTI** e di una vasca raccogli olio con filtro • Prices **INCLUDE BASKETS** and one oil draining tank with filter • Preise **ENTHALTEN KÖRBE** und eine Ölsammelwanne mit Filter • Les prix **COMPRENENT LES PANIERS** et un bac recueil huile • Los precios **INCLUYEN LOS CESTOS** y una cuba recoge aceite con filtro.

FRIGGITRICI GAS

unika700

GAS DEEP FAT FRYERS • GAS FRITEUSEN
FRITEUSES GAZ • FREIDORAS A GAS

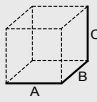
CODICE Code Kode Code Codigo	 (A x B x C) mm	VOL./PESO Vol./Weight Vol./Gewicht Vol./Poids Vol./Pesos m ³ /kg	GAS kW	VAC 230-1N 50/60 Hz kW	CAPACITÀ Capacity Inhalt Capacité Capacidad Lt.	PREZZO Price Preis Prix Precio €
--	---	--	-----------	---------------------------------	--	---

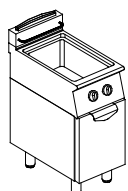

 **FG7413P** 400x700x900 0,5/58 12 0,1 13 **3.100,00**

 **FG7417P** 400x700x900 0,5/68 16 0,1 17 **3.265,00**

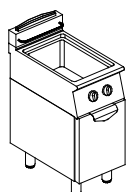

 **FG7413MP** 400x700x900 0,5/68 12 0,1 13 **3.719,00**

 **FG7417MP** 400x700x900 0,8/78 16 0,1 17 **3.859,00**

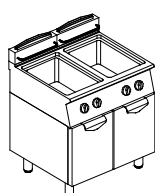

 **FG7813P** 800x700x900 0,9/100 24 0,2 13 + 13 **5.576,00**

 **FG7817P** 800x700x900 0,9/121 33 0,2 17 + 17 **5.622,00**

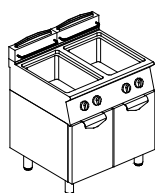

 **FG7813MP** 800x700x900 0,9/100 24 0,2 13 + 13 **6.578,00**

 **FG7817MP** 800x700x900 0,9/121 33 0,2 17 + 17 **6.753,00**



**ELECTRONIC
MELTING CONTROL**

...M

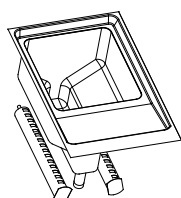

Scambiatori di calore ESTERNI alla vasca
EXTERNAL heat exchangers
Warmetauschern AUßERHALB der Becken
Échangeurs de chaleur EXTERNES à la cuve
Intercambiadores de calor EXTERIORES a la cuba

I prezzi sono **INCLUSIVI DEI CESTI** e di una vasca raccogli olio con filtro • Prices **INCLUDE BASKETS** and one oil draining tank with filter • Preise **ENTHALTEN KÖRBE** und eine Ölsammelwanne mit Filter • Les prix **COMPRENNENT LES PANIERS** et un bac recueil huile • Los precios **INCLUYEN LOS CESTOS** y una cuba recoge aceite con filtro.

CE IMQ

KOREA GAS SAFETY CORPORATION

CERTIGAZ

GIORIK 51
INNOVATIVE COOKING EQUIPMENT SINCE 1963

unika700

unika700 FRIGGITRICI ELETTRICHE

ELECTRIC DEEP FAT FRYERS • ELEKTRO FRITEUSEN
FRITEUSES ÉLECTRIQUES • FREIDORAS ELÉCTRICAS

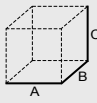
CODICE Code Kode Code Codigo	 (A x B x C) mm	VOL./PESO Vol./Weight Vol./Gewicht Vol./Poids Vol./Pesos m³/kg	GAS kW	VAC 400-3N 50/60 Hz kW	CAPACITÀ Capacity Inhalt Capacité Capacidad Lt.	PREZZO Price Preis Prix Precio €
--	---	---	-----------	---------------------------------	--	---

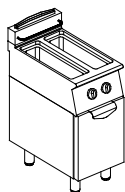

⚡ **FE7207** 400x700x900 0,5/62 14 8 + 8 **3.542,00**

⚡ **FE7207M** 400x700x900 0,5/62 14 8 + 8 **4.279,00**

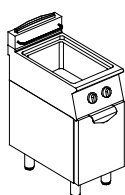

⚡ **FE7113** 400x700x900 0,5/60 12 13 **2.412,00**

⚡ **FE7117** 400x700x900 0,5/70 16,5 17 **2.723,00**

⚡ **FE7113M** 400x700x900 0,5/48 12 13 **2.976,00**

⚡ **FE7117M** 400x700x900 0,5/55 16,5 17 **3.205,00**

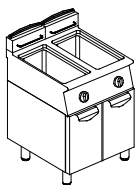

⚡ **FE7215** 600x700x900 0,6/76 20,4 15 + 15 **3.841,00**

⚡ **FE7215M** 600x700x900 0,6/76 20,4 15 + 15 **4.262,00**

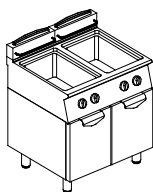

⚡ **FE7213** 800x700x900 0,9/76 24 13 + 13 **4.107,00**

⚡ **FE7217** 800x700x900 0,9/90 33 17 + 17 **4.656,00**

⚡ **FE7213M** 800x700x900 0,9/76 24 13 + 13 **5.058,00**

⚡ **FE7217M** 800x700x900 0,9/90 33 17 + 17 **5.370,00**



...M

ELECTRONIC
MELTING CONTROL

I prezzi sono **INCLUSIVI DEI CESTI** e di una vasca raccogli olio con filtro • Prices **INCLUDE BASKETS** and one oil draining tank with filter • Preise **ENTHALTEN KÖRBE** und eine Ölsammelwanne mit Filter • Les prix **COMPRENENT LES PANIERS** et un bac recueil huile • Los precios **INCLUYEN LOS CESTOS** y una cuba recoge aceite con filtro.

ACCESSORI PER FRIGGITRICI

unika700

ACCESSORIES FOR FRYERS • ZUBEHÖR FÜR FRITZEUSEN
ACCESSOIRES POUR FRITEUSES • ACCESORIOS PARA FREIDORAS

CODICE Code Kode Code Codigo	 (A x B x C) mm	PREZZO Price Preis Prix Precio €
--	---	---

FRIGGITRICI A GAS CON SCAMBIATORI DI CALORE INTERNI
GAS FRYER WITH INTERNAL HEAT EXCHANGERS



FRIGGITRICI ELETTRICHE
ELECTRIC FRYERS

FRIGGITRICI A GAS CON SCAMBIATORI DI CALORE ESTERNI
GAS FRYER WITH EXTERNAL HEAT EXCHANGERS

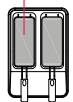
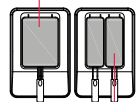
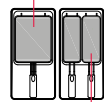
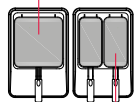
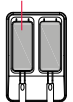
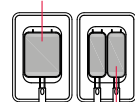
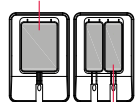
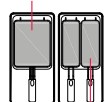
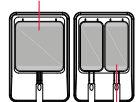
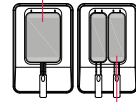
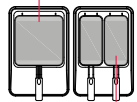

8 + 8 Lt	10 + 10 Lt Modello Top Countertop Model	13 Lt 13 + 13 Lt	FG7215T - FG7215MT 13 + 13 Lt	15 Lt 15 + 15Lt	17 Lt 17 + 17 Lt
2012898 		2012893  2012892 NO FG7215T \ FG7215MT	2003003  2003002 FG7215T \ FG7215MT		2012896  2012895
2012898 	2013949  2014725	2012893  2012892		2003003  2003002	2012896  2012895
		2015150  2015154			2012896  2012895

Cestelli per friggitorici • Baskets for fryers • Körbe für Friteusen • Paniers pour friteuses • Cestos para freidoras

2015154	105x310x120		58,00
2015150	215x310x120		70,00
2012895	146x310x120		66,00
2012896	300x310x120		77,00
2012898	130x310x120		58,00
2012892	113x310x120		58,00
2012893	230x310x120		70,00
2003002	113x290x120	Per • For • Für • Pour • Para: FE7215, FE7215M, FG7215T, FG7215MT	53,00
2003003	230x290x120	Per • For • Für • Pour • Para: FE7215, FE7215M, FG7215T, FG7215MT	70,00



unika700

ACCESSORIES FOR FRYERS • ZUBEHÖR FÜR FRITTEUSEN
ACCESSOIRES POUR FRITEUSES • ACCESORIOS PARA FREIDORAS

CODICE Code Kode Code Codigo		PREZZO Price Preis Prix Precio €
Vasche raccogli olio con filtro • Oil tanks with filter • Ölsammelwanne mit Filter Bacs de récupération huile avec filtre • Cubas recoge aceite con filtro		
2015470	Per friggitorici gas • For gas deep fat fryers • Für Gas Friteusen Pour friteuses gaz • Para freidoras a gas	151,00
2013248	Per friggitorici elettriche • For electric deep fat fryers • Für Elektro Friteusen Pour friteuses électriques • Para freidoras eléctricas	151,00
2010905	Per • For • Für • Pour • Para: FE7215, FE 7215M, FG7215T, FG7215MT	151,00

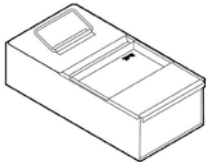

BRASIERE ROVESCIBILI

TILTING BRATT PANS • KIPPBRATPFANNEN
SAUTEUSES BASCULANTES • SARTENES BASCULANTES

CODICE Code Kode Code Codigo	 (A x B x C) mm	VOL./PESO Vol./Weight Vol./Gewicht Vol./Poids Vol./Pesos m ³ /kg	GAS kW	VAC 230-1N 50/60 Hz kW	VAC 400-3N 50/60 Hz kW	PREZZO Price Preis Prix Precio €
--	--------------------	--	-----------	---------------------------------	---------------------------------	---

Brasiera sollevamento manuale • Manual tilting • Manuelles Heben
Levage manual • Levantamiento manual

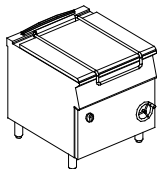

BG74FM	800x700x900 50 Lt.	0,9/160	12			5.171,00
<i>Non disponibile per la Comunità Europea • Not available for UE market</i>						
BG74XM	800x700x900 50 Lt.	0,9/160	12			6.164,00

Brasiera sollevamento manuale • Manual tilting • Manuelles Heben
Levage manual • Levantamiento manual

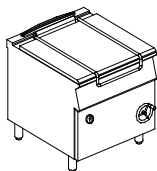

BE74FM	800x700x900 50 Lt.	0,9/160		10		5.347,00
<i>Non disponibile per la Comunità Europea • Not available for UE market</i>						
BE74XM	800x700x900 50 Lt.	0,9/160		10		6.249,00

F Vasca in ferro • Mild iron tank • Becken aus Eisen • Cuve en fer • Cuba de hierro
Non disponibile per la comunità Europea • Not available for UE market • Nicht erhältlich für die Europäische Gemeinschaft • Non disponible pour la Communauté européenne • No disponible para la Comunidad europea

X Vasca in acciaio inossidabile Duplex 2304 • Duplex 2304 stainless steel tank • Becken aus rostfreiem Stahl Duplex 2304 • Cuve en acier inoxydable Duplex 2304 • Cuba de acero inoxidable Duplex 2304

PENTOLE

unika700

BOILING PANS • KOCHKESSEL • MARMITES • MARMITAS

CODICE Code Kode Code Codigo	 (A x B x C) mm	VOL./PESO Vol./Weight Vol./Gewicht Vol./Poids Vol./Pesos m ³ /kg	GAS kW	VAC 400-3N 50/60 Hz kW	PREZZO Price Preis Prix Precio €
--	---	--	-----------	---------------------------------	---

Pentole a gas diretto • Gas direct heating boiling pans • Gas-Kochkessel direkt beheizt
Marmites à gaz chauffage direct • Marmitas a gas con calentamiento directo

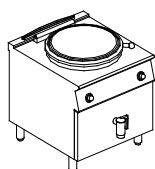

 PGD705	800x700x900 50 Lt.	1,1/120	12		5.125,00
---	-----------------------	---------	----	--	-----------------

Pentole a gas indiretto • Gas indirect heating boiling pans • Gas-Kochkessel indirekt beheizt
Marmites gaz chauffage indirect • Marmitas a gas con calentamiento indirecto

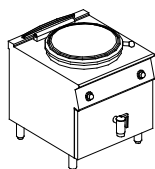

 PGI705	800x700x900 50 Lt.	1,1/120	12		7.238,00
---	-----------------------	---------	----	--	-----------------

Pentole indirette elettriche • Electric indirect heating boiling pans • Elektro-Kochkessel indirekt beheizt
Marmites électriques chauffage indirect • Marmitas eléctricas con calentamiento indirecto

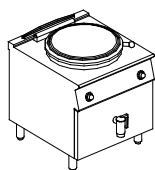

 PEI705	800x700x900 50 Lt.	1,1/120		10	7.109,00
---	-----------------------	---------	--	----	-----------------

ACCESSORI PER PENTOLE

ACCESSORIES FOR BOILING PANS • KOCHKESSELZUBEHÖR
ACCESSOIRES POUR MARMITES • ACCESORIOS PARA MARMITAS

Cestelli • Baskets • Körbe • Paniers • Cestos



5920160	50 Lt.		Ø mm 360x404H		860,00
----------------	--------	--	---------------	--	---------------

Griglietta di scarico • Plug hole filter • Ablaufgitter • Grille pour bonde • Rejilla de desagüe



2019860					39,00
----------------	--	--	--	--	--------------

unika700

NEUTRAL UNITS • ARBEITSELEMENTE
ÉLÉMENTS NEUTRES • MUEBLES NEUTROS

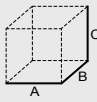
CODICE Code Kode Code Codigo	 (A x B x C) mm	VOL./PESO Vol./Weight Vol./Gewicht Vol./Poids Vol./Pesos m³/kg	VAC 230-1N 50/60 Hz kW	PREZZO Price Preis Prix Precio €
---	--	---	---	---

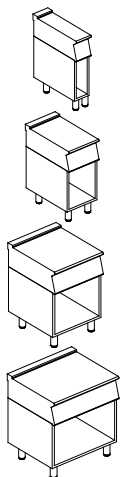

EN710G 200x700x900 0,3/40 **660,00**

EN720G 400x700x900 0,5/50 **893,00**

EN730G 600x700x900 0,7/60 **977,00**

EN740G 800x700x900 0,9/75 **1.175,00**

Con cassetto • With drawer • Mit Schublade • Avec tiroir • Con cajón

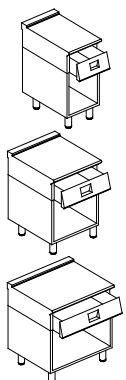

EN72CG 400x700x900 0,5/55 **1.220,00**

EN73CG 600x700x900 0,7/60 **1.425,00**

EN74CG 800x700x900 0,9/80 **1.497,00**

ACCESSORI

ACCESSORIES • ZUBEHÖR • ACCESSOIRES • ACCESORIOS

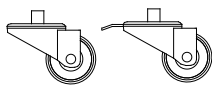

Kit ruote • Kit castor • Rädersatz • Kit roulettes • Kit ruedas

KITT348 4 ruote (2 autobloccanti) • 4 wheels (2 self-locking) • 4 Räder (2 selbstsichernd) • 4 roues (2 autobloquantes) • 4 ruedas (2 autobloqueantes) **195,00**

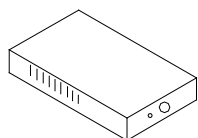

Elemento riscaldante ventilato per armadi • Ventilated cupboard base warmer • Umluft-Heizblock für Schrank • Corps de chauffe ventilé pour armoire • Elemento calentador ventilado para armarios

6000020 310x250x90 2 **518,00**

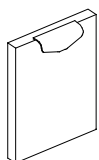

Porte • Doors • Flügeltüren • Portes • Puertas

2026529 Modulo 300 • Module 300 • Modul 300 • Module 300 • Mòdulo 300 **151,00**

2016437 Modulo 400 • Module 400 • Modul 400 • Module 400 • Mòdulo 400 **156,00**

ACCESSORI

unika700

ACCESSORIES • ZUBEHÖR • ACCESSOIRES • ACCESORIOS

CODICE	PREZZO
Code	Price
Kode	Preis
Code	Prix
Codigo	Precio
	€



Colonnina acqua • Water tap • Wasserhahn • Robinet de l'eau • Poste agua

7060077	510x725h	325,00
----------------	----------	---------------

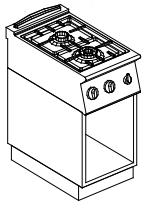

Zoccolatura • Plinth • Sockelblende • Socle • Zócalo

130,00 x ml

Kit supporto a ponte • Kit for bridge cooking suites • Satz für Brückenkochblöcke
Kit pour bloc de cuisson à pont • Kit soporte tipo puente

2020469	L = 400 mm	132,00
2020470	L = 600 mm	137,00
2020471	L = 800 mm	145,00
2020472	L = 1000 mm	150,00
2020473	L = 1200 mm	156,00
2020474	L = 1400 mm	168,00
2020475	L = 1600 mm	198,00
2020476	L = 1800 mm	243,00

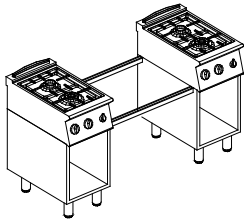

Corrimano • Trayslide • Tabletrutsche • Rampe à plateaux • Barra

168,00 x ml

2020477	L = 400 mm	68,00
2020478	L = 800 mm	135,00
2020479	L = 1200 mm	203,00
2020480	L = 1600 mm	270,00

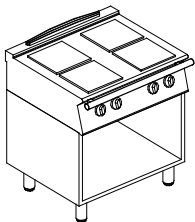

Corrimano portapiatti • Trayslide • Tabletrutsche • Rampe à plateaux • Barra para platos

194,00 x ml

2020481	L = 400 mm	78,00
2020482	L = 800 mm	156,00
2020483	L = 1200 mm	233,00
2020484	L = 1600 mm	312,00

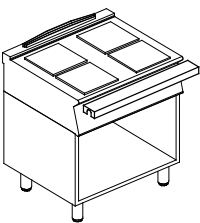

Struttura porta teglie • Tray holder structure • Backblechablage • Structure porte-plaque • Estructura para bandejas

2022727	L = 800 mm	Su richiesta On request Auf Anfrage Sur demande Previa solicitud
2022728	L = 1200 mm	
2022729	L = 1600 mm	
2022730	L = 2000 mm	
2022731	L = 2400 mm	
2022732	L = 2800 mm	

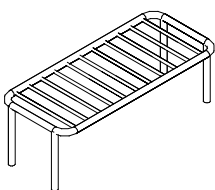

unika700

unika700 TOP

GIORIK
INNOVATIVE COOKING EQUIPMENT SINCE 1963

CUCINE A GAS

GAS RANGES • GASHERDE • FORNEAUX GAZ • COCINAS A GAS

CODICE Code Kode Code Codigo		VOL./PESO Vol./Weight Vol./Gewicht Vol./Poids Vol./Pesos	GAS	VAC	VAC	PREZZO Price Preis Prix Precio
				230-1N 50/60 Hz	400-3N 50/60 Hz	
	(A x B x C) mm	m ³ /kg	kW	kW	kW	

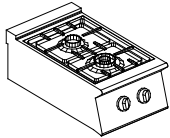

ECG720T

400x700x307

0,2/30

9,5

1.194,00

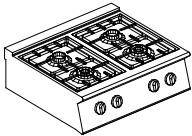

ECG740T

800x700x307

0,35/60

19

1.908,00

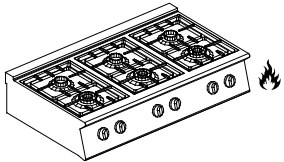

ECG760T

1200x700x307

0,7/90

28,5

2.702,00

CUCINE A GAS

GAS RANGES • GASHERDE • FORNEAUX GAZ • COCINAS A GAS

CODICE Code Kode Code Codigo		VOL./PESO Vol./Weight Vol./Gewicht Vol./Poids Vol./Pesos	GAS	VAC	VAC	PREZZO Price Preis Prix Precio
				230-1N 50/60 Hz	400-3N 50/60 Hz	
	(A x B x C) mm	m ³ /kg	kW	kW	kW	

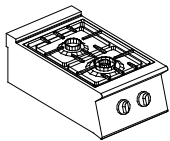

CG720T

400x700x307

0,2/30

12

1.480,00

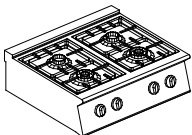

CG740T

800x700x307

0,35/60

24

2.393,00

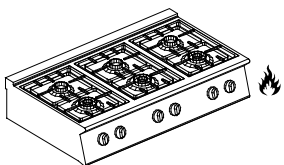

CG760T

1200x700x307

0,7/90

36

3.377,00

CONFIGURAZIONE BRUCIATORI

CONFIGURATION BURNERS • KONFIGURATION BRENNER
CONFIGURATION BRÛLEURS • CONFIGURACION DE QUEMADORES

LineaBase
TOP 700

STANDARD

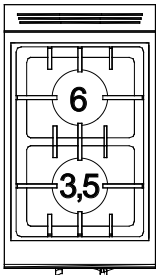

9,5 kW

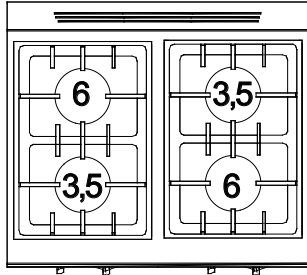

19 kW

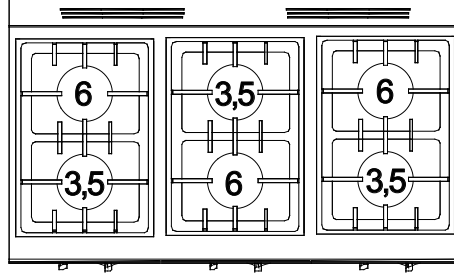

28,5 kW

unika700

CONFIGURAZIONE BRUCIATORI

CONFIGURATION BURNERS • KONFIGURATION BRENNER
CONFIGURATION BRÛLEURS • CONFIGURACION DE QUEMADORES

unika700
TOP

STANDARD

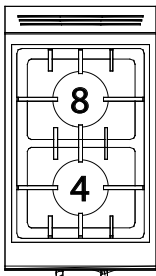

12 kW

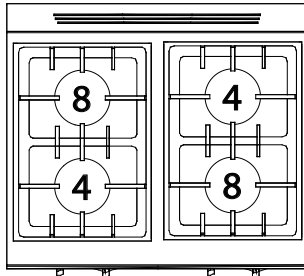

24 kW

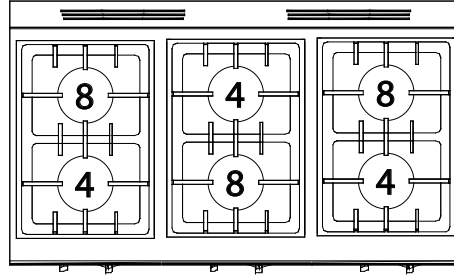

36 kW

Extra prezzo per configurazioni speciali
Extra price for special configurations • Extra Preis für Sonderkonfigurationen
Extra prix pour configurations spéciales • Extra precio para configuraciones especiales

16 kW

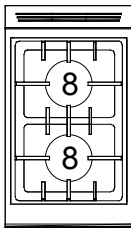

+90,00 €

28 kW

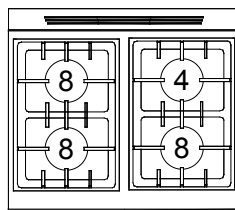

+90,00 €

32 kW

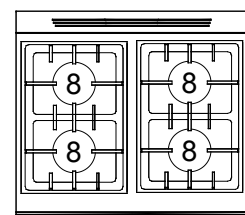

+181,00 €

40 kW

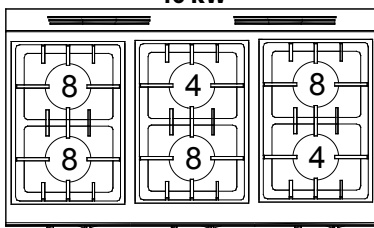

+90,00 €

48 kW

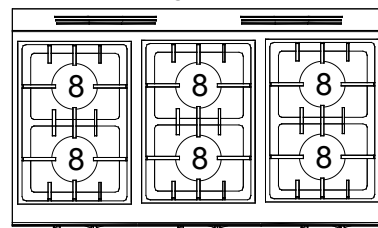

+269,00 €

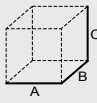
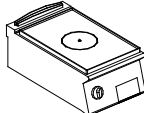
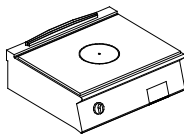
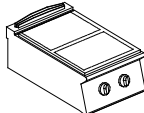
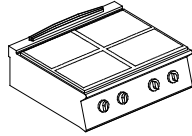
CODICE Code Kode Code Codigo		VOL./PESO Vol./Weight Vol./Gewicht Vol./Poids Vol./Pesos	GAS	VAC		PREZZO Price Preis Prix Precio
				230-1N 50/60 Hz	400-3N 50/60 Hz	
	(A x B x C) mm	m ³ /kg	kW	kW	kW	€
 TG720T	400x700x307	0,2/50	6			2.172,00
 TG740T	800x700x307	0,35/90	12			2.616,00
 TE720T	400x700x307	0,2/50			4	2.841,00
 TE740T	800x700x307	0,35/90			10	4.100,00

ACCESSORI

ACCESSORIES • ZUBEHÖR • ACCESSOIRES • ACCESORIOS



Leverino • Lever • Eisen • Petit levier • Palanca

2019661

66,00

CUCINE ELETTRICHE

unika700
TOP

ELECTRIC RANGE • ELEKTROHERDE
FORNEAUX ÉLECTRIQUES • COCINAS ELÉCTRICAS

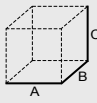
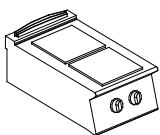
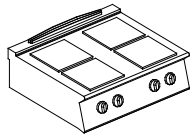
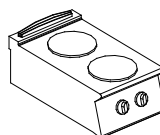
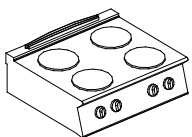
CODICE Code Kode Code Codigo		VOL./PESO Vol./Weight Vol./Gewicht Vol./Poids Vol./Pesos	GAS	VAC		PREZZO Price Preis Prix Precio
				230-1N 50/60 Hz	400-3N 50/60 Hz	
	(A x B x C) mm	m ³ /kg	kW	kW	kW	€
 ⚡ CE72QT	400x700x307 2x(220x220)	0,2/40			5,2	1.781,00
 ⚡ CE74QT	800x700x307 4x(220x220)	0,35/60			10,4	2.898,00
 ⚡ CE72TT	400x700x307 2x ø220	0,2/35			5,2	1.231,00
 ⚡ CE74TT	800x700x307 4x ø220	0,35/55			10,4	1.659,00

FRIGGITRICI ELETTRICHE CON GRUPPO RESISTENZE SOLLEVABILI

ELECTRIC DEEP FAT FRYERS WITH LIFTABLE HEATING ELEMENTS • ELEKTRO FRITEUSEN MIT DREHBAREN SCHALTCASTEN • FRITEUSES ÉLECTRIQUES AVEC GROUPE RÉSTANCES BASCULANT • FREIDORAS ELÉCTRICAS CON GRUPO DE RESISTENCIAS EXTRAIBLES

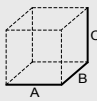
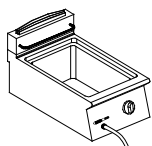
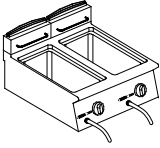
CODICE Code Kode Code Codigo		VOL./PESO Vol./Weight Vol./Gewicht Vol./Poids Vol./Pesos	LITRI	VAC		PREZZO Price Preis Prix Precio
				230-1N 50/60 Hz	400-3N 50/60 Hz	
	(A x B x C) mm	m ³ /kg	Lt.	kW	kW	€
 ⚡ FE7110T	400x700x307		10		10	2.336,00
 ⚡ FE7210T	800x700x307		10+10		20	3.693,00

Per i cesti vedi pagina 53 • For baskets see page 53 • Für Körbe siehe Seite 53 • Pour les paniers voir page 53
Para los cestos ver página 53

CUCINE ELETTRICHE VETROCERAMICA

ELECTRIC RANGES CERAMIC GLASS • ELEKTROHERDE GLASKERAMIK
PLAQUES DE CUISSON EN VITROCÉRAMIQUE • COCINAS ELECTRICAS VETROCERAMICA

CODICE Code Kode Code Codigo		VOL./PESO Vol./Weight Vol./Gewicht Vol./Poids Vol./Pesos	GAS	VAC		PREZZO Price Preis Prix Precio
				230-1N 50/60 Hz	400-3N 50/60 Hz	
	(A x B x C) mm	m ³ /kg	kW	kW	kW	€

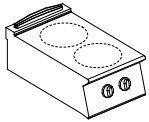

⚡ CV720T	400x700x307 2x ø230	0,2/35			4,2	1.757,00
-----------------	------------------------	--------	--	--	-----	-----------------

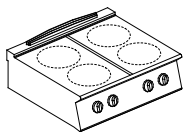

⚡ CV740T	800x700x307 4x ø230	0,35/55			8,4	2.912,00
-----------------	------------------------	---------	--	--	-----	-----------------

CUCINA A INDUZIONE

INDUCTION RANGES • INDUKTIONSHERDE • PLAQUES DE CUISSON À INDUCTION
COCINAS ELECTRICAS A INDUCCIÓN

CODICE Code Kode Code Codigo		VOL./PESO Vol./Weight Vol./Gewicht Vol./Poids Vol./Pesos	GAS	VAC		PREZZO Price Preis Prix Precio
				230-1N 50/60 Hz	400-3N 50/60 Hz	
	(A x B x C) mm	m ³ /kg	kW	kW	kW	€

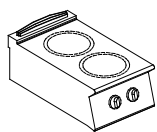

⚡ CI720T	400x700x307 2x ø230	0,2/45			7	7.934,00
-----------------	------------------------	--------	--	--	---	-----------------

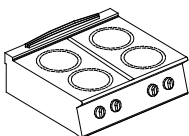

⚡ CI740T	800x700x307 4x ø230	0,35/65			14	12.826,00
-----------------	------------------------	---------	--	--	----	------------------

WOK

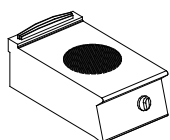

⚡ CW720T	400x700x307 1x ø300	0,2/45			5	6.510,00
-----------------	------------------------	--------	--	--	---	-----------------

AQUA-GRILL A GAS

GAS STEAMGRILL • DAMPF GRILL, GAS AUSFÜHRUNG • GRILLE VAPEUR À GAZ
 VAPOR BARBACOA DE GAS

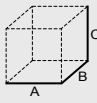
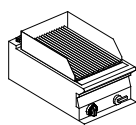
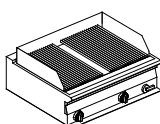
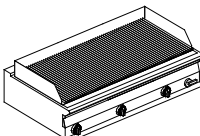
CODICE Code Kode Code Codigo		VOL./PESO Vol./Weight Vol./Gewicht Vol./Poids Vol./Pesos	GAS	VAC		PREZZO Price Preis Prix Precio
				230-1N 50/60 Hz	400-3N 50/60 Hz	
	(A x B x C) mm	m ³ /kg	kW	kW	kW	€
 GL72TV	400x700x307	0,2/45	8,5			2.479,00
 GL74TV	800x700x307	0,35/75	17			3.648,00
 GL76TV	1200x700x307	0,7/90	25,5			4.570,00

AQUA-GRILL ELETTRICI

ELECTRIC STEAMGRILL • DAMPF GRILL, ELEKTROAUSFÜHRUNG • GRILLE VAPEUR ÉLECTRIQUE
 VAPOR BARBACOA ELÉCTRICO

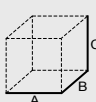
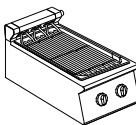
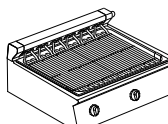
CODICE Code Kode Code Codigo		VOL./PESO Vol./Weight Vol./Gewicht Vol./Poids Vol./Pesos	GAS	VAC		PREZZO Price Preis Prix Precio
				230-1N 50/60 Hz	400-3N 50/60 Hz	
	(A x B x C) mm	m ³ /kg	kW	kW	kW	€
 GL72TE	400x700x307	0,2/45			4	2.941,00
 GL74TE	800x700x307	0,35/75			8	4.033,00

GRIGLIE A PIETRA LAVICA

LAVA ROCK GRILLS • LAVASTEINGRILLS
 GRILLES À PIERRE VOLCANIQUE • BARBACOA DE PIEDRA LÁVICA

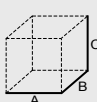
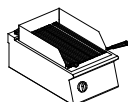
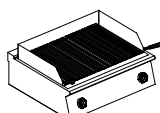
CODICE Code Kode Code Codigo		VOL./PESO Vol./Weight Vol./Gewicht Vol./Poids Vol./Pesos	GAS	VAC		PREZZO Price Preis Prix Precio
				230-1N 50/60 Hz	400-3N 50/60 Hz	
	(A x B x C) mm	m ³ /kg	kW	kW	kW	€
Griglia per carne • Grill for meat • Fleischrost • Grille pour viande • Rejilla para carne						
 GL72TGC	400x700x307	0,2/45	10			2.225,00
 GL74TGC	800x700x307	0,35/75	20			3.310,00

CUOCIPASTA ELETTRICI

ELECTRIC PASTA COOKER • ELEKTRO NUDELKOCHER
CUISEIERS À PÂTE ÉLECTRIQUES • CUECE-PASTAS ELÉCTRICOS

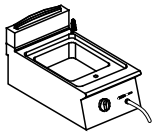
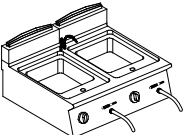
CODICE Code Kode Code Codigo	(A x B x C) mm	VOL./PESO Vol./Weight Vol./Gewicht Vol./Poids Vol./Pesos	GAS kW	VAC 400-3N 50/60 Hz kW	CAPACITA' Capacity Inhalt Capacité Capacidad Lt.	PREZZO Price Preis Prix Precio €
 CPE726T	400x700x307	0,2/45		5,5	20	2.781,00
 CPE746T	800x700x307	0,35/60		11	20+20	4.565,00

ACCESSORI PER CUOCIPASTA TOP LT. 20 / LT. 20+20

ACCESSORIES FOR PASTA BOILERS • NUDELKOCHERZUBEHÖR
ACCESSOIRES POUR CUISEUR À PÂTES • ACCESORIOS PARA CUECE-PASTAS

CODICE Code Kode Code Codigo	PREZZO Price Preis Prix Precio €
--	---

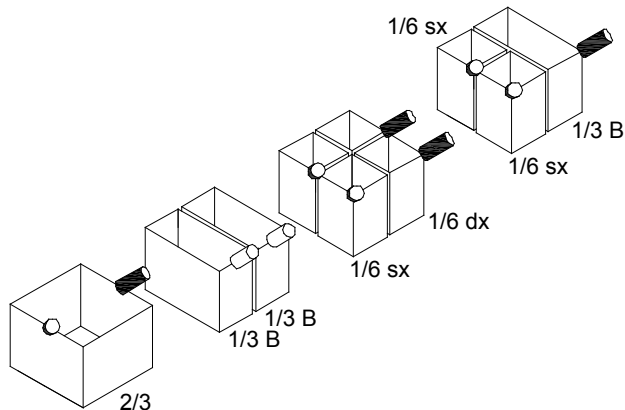

Cestelli • Baskets • Körbe • Paniers • Cestos

2028758	2/3 GN	mm 290x296x135H	197,00
2028683	1/3 GN (B)	mm 143x296x135H	183,00
2028682	1/6 GN (dx)	mm 142x158x135H	144,00
2028681	1/6 GN (sx)	mm 142x158x135H	144,00

Coperchi per cuocipasta • Lids for pasta cooker • Deckel für Nudelkocher
Couvercle pour cuiseurs à pâtes • Tapa para clecepasta

 2004151	1 x GN 2/3	39,00
--	------------	--------------

FRY TOP A GAS

unika700
TOP

GAS GRIDDLE PLATES • GAS-GRILLPLATTEN
GRILLADES GAZ • FRY-TOP A GAS

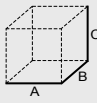
CODICE Code Kode Code Codigo	 (A x B x C) mm	VOL./PESO Vol./Weight Vol./Gewicht Vol./Poids Vol./Pesos m ³ /kg	GAS kW	VAC 230-1N 50/60 Hz kW	VAC 400-3N 50/60 Hz kW	PREZZO Price Preis Prix Precio €
--	---	--	-----------	---------------------------------	---------------------------------	---

Liscio • Smooth • Glatt • Lisse • Liso

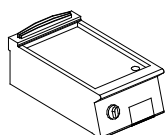

 FLG72TF	400x700x307	0,5/50	7			1.712,00
--	-------------	--------	---	--	--	-----------------

Non disponibile per la Comunità Europea • Not available for UE market

 FLG72CRX	400x700x307	0,5/50	7			2.016,00
---	-------------	--------	---	--	--	-----------------

Termostato • Thermostated • Thermostate • Thermostatisiert • Termostatizado

Rigato • Ribbed • Gerillt • Nervuré • Acanalado

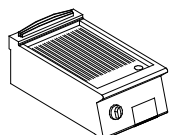

 FRG72TF	400x700x307	0,5/50	7			2.061,00
--	-------------	--------	---	--	--	-----------------

Non disponibile per la Comunità Europea • Not available for UE market

 FRG72CRX	400x700x307	0,5/50	7			2.327,00
---	-------------	--------	---	--	--	-----------------

Termostato • Thermostated • Thermostate • Thermostatisiert • Termostatizado

Liscio • Smooth • Glatt • Lisse • Liso

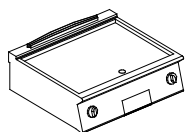

 FLG741TF	800x700x307	0,9/80	14			2.651,00
---	-------------	--------	----	--	--	-----------------

Non disponibile per la Comunità Europea • Not available for UE market

 FLG741CRX	800x700x307	0,9/80	14			3.165,00
--	-------------	--------	----	--	--	-----------------

Termostato • Thermostated • Thermostate • Thermostatisiert • Termostatizado

Rigato • Ribbed • Gerillt • Nervuré • Acanalado

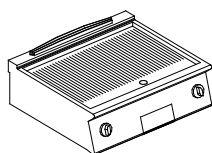

 FRG741TF	800x700x307	0,9/80	14			2.916,00
---	-------------	--------	----	--	--	-----------------

Non disponibile per la Comunità Europea • Not available for UE market

 FRG741CRX	800x700x307	0,9/80	14			3.740,00
--	-------------	--------	----	--	--	-----------------

Termostato • Thermostated • Thermostate • Thermostatisiert • Termostatizado

Liscio-Rigato • Smooth-Ribbed • Glatt-Gerillt • Lisse-Nervuré • Liso-Acanalado

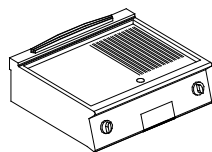

 FMG741TF	800x700x307	0,9/80	14			2.822,00
---	-------------	--------	----	--	--	-----------------

Non disponibile per la Comunità Europea • Not available for UE market

 FMG741CRX	800x700x307	0,9/80	14			3.446,00
--	-------------	--------	----	--	--	-----------------

Termostato • Thermostated • Thermostate • Thermostatisiert • Termostatizado

F Piastra in ferro • Mild iron plate • Platte aus Eisen • Plaque en fer • Placa de hierro
Non disponibile per la comunità Europea • Not available for UE market • Nicht erhältlich für die Europäische Gemeinschaft • Non disponible pour la Communauté européenne • No disponible para la Comunidad europea

CRX Piastra in acciaio spessore 15 mm con finitura cromata satinata
Conforme al regolamento CE 1935/2004 riguardante materiali e oggetti a contatto con gli alimenti. Il materiale è antiaderente e garantisce resistenza alla corrosione e ai graffi. • Steel Chrome-plated satin finish, 15 mm thickness. In compliance with UE Regulation 1935/2004 on materials and articles in contact with food. The material is non-stick and guarantees resistance to corrosion and scratches. • Stahl Verchromt satiniert, 15 mm dick. • Acier chromé satiné, épaisseur 15 mm. • Acero Cromado satinado, 15 mm de espesor.



CODICE Code Kode Code Codigo	 (A x B x C) mm	VOL./PESO Vol./Weight Vol./Gewicht Vol./Poids Vol./Pesos m ³ /kg	GAS kW	VAC 230-1N 50/60 Hz kW	VAC 400-3N 50/60 Hz kW	PREZZO Price Preis Prix Precio €
--	---	--	-----------	---------------------------------	---------------------------------	---

Liscio • Smooth • Glatt • Lisse • Liso

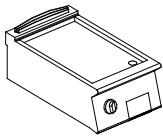

⚡ FLE72TF	400x700x307	0,5/50			6	1.859,00
Non disponibile per la Comunità Europea • Not available for UE market						

⚡ FLE72TCRX	400x700x307	0,5/50			6	2.018,00
--------------------	-------------	--------	--	--	---	-----------------

Rigato • Ribbed • Gerillt • Nervuré • Acanalado

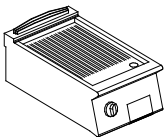

⚡ FRE72TF	400x700x307	0,5/50			6	2.010,00
Non disponibile per la Comunità Europea • Not available for UE market						

⚡ FRE72TCRX	400x700x307	0,5/50			6	2.142,00
--------------------	-------------	--------	--	--	---	-----------------

Liscio • Smooth • Glatt • Lisse • Liso

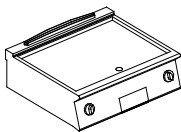

⚡ FLE741TF	800x700x307	0,9/80			12	2.859,00
Non disponibile per la Comunità Europea • Not available for UE market						

⚡ FLE741TCRX	800x700x307	0,9/80			12	3.159,00
---------------------	-------------	--------	--	--	----	-----------------

Rigato • Ribbed • Gerillt • Nervuré • Acanalado

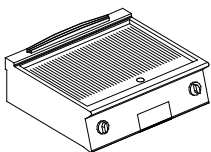

⚡ FRE741TF	800x700x307	0,9/80			12	3.115,00
Non disponibile per la Comunità Europea • Not available for UE market						

⚡ FRE741TCRX	800x700x307	0,9/80			12	3.477,00
---------------------	-------------	--------	--	--	----	-----------------

Liscio-Rigato • Smooth-Ribbed • Glatt-Gerillt • Lisse-Nervuré • Liso-Acanalado

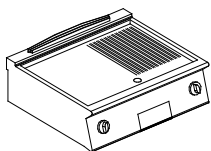

⚡ FME741TF	800x700x307	0,9/80			12	2.928,00
Non disponibile per la Comunità Europea • Not available for UE market						

⚡ FME741TCRX	800x700x307	0,9/80			12	3.365,00
---------------------	-------------	--------	--	--	----	-----------------

F Piastra in ferro • Mild iron plate • Platte aus Eisen • Plaque en fer • Placa de hierro
 Non disponibile per la comunità Europea • Not available for UE market
 • Nicht erhältlich für die Europäische Gemeinschaft • Non disponible pour la Communauté européenne • No disponible para la Comunidad europea

CRX Piastra in acciaio spessore 15 mm con finitura cromata satinata
 Conforme al regolamento CE 1935/2004 riguardante materiali e oggetti a contatto con gli alimenti. Il materiale è antiaderente e garantisce resistenza alla corrosione e ai graffi. • Steel Chrome-plated satin finish, 15 mm thickness. In compliance with UE Regulation 1935/2004 on materials and articles in contact with food. The material is non-stick and guarantees resistance to corrosion and scratches. • Stahl Verchromt satiniert, 15 mm dick. • Acier chromé satiné, épaisseur 15 mm. • Acero Cromado satinado, 15 mm de espesor.

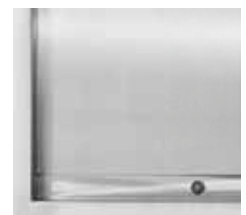



BAGNO MARIA

BAIN MARIES • BAIN-MARIES • BAIN-MARIE • BAÑO MARÍA

unika700
TOP

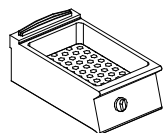
CODICE Code Kode Code Codigo	 (A x B x C) mm	VOL./PESO Vol./Weight Vol./Gewicht Vol./Poids Vol./Pesos m ³ /kg	GAS kW	VAC 230-1N 50/60 Hz kW	VAC 400-3N 50/60 Hz kW	PREZZO Price Preis Prix Precio €
--	---	--	-----------	---------------------------------	---------------------------------	---



 BM720T GN 1/1	400x700x307	0,5/30		1,1		1.428,00
---	-------------	--------	--	-----	--	-----------------

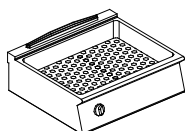

 BM740T GN 2/1	800x700x307	0,9/45		2,2		2.117,00
---	-------------	--------	--	-----	--	-----------------

I prezzi dei bagnomaria **NON COMPRENDONO I CESTELLI** • The **BASKETS ARE NOT INCLUDED** in the price of bain maries • Die Preise der Bain Maries **ENTHALTEN KEINE KÖRBE** • Les prix des bain marie **NE COMPRENENT PAS LES PANIERS** • Los precios de los baño maría **NO INCLUYEN LO CESTOS**.

SCALDAPATATE

CHIPS SCUTTLES • POMMES FRITES-WÄRMER • BAC DE SALAGE • CALIENTAPATATAS

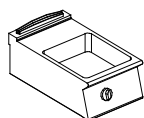

 SP720T	400x700x307 GN 2/3			1,38		1.537,00
--	-----------------------	--	--	------	--	-----------------

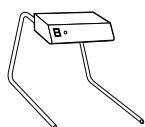

 LSR4911	400x390x410	0,12/13		0,75		748,00
--	-------------	---------	--	------	--	---------------

ACCESSORI

ACCESSORI • ACCESSORIES • ZUBEHÖR • ACCESSOIRES

Bacinelle • Basins • Behälter • Bacs • Recipientes

2103135	GN 1/4 H150	55,00
2103080	GN 1/2 H150	72,00
2103107	GN 2/3 H150	89,00
2103134	GN 1/1 H150	108,00
2103144	GN 2/1 H150	184,00



Coperchi • Lids • Deckel • Couvercles • Tapas

2103202	Per • For • Für • Pour • Para: GN 1/4	23,00
2103077	Per • For • Für • Pour • Para: GN 1/2	21,00
2103201	Per • For • Für • Pour • Para: GN 2/3	39,00
2103106	Per • For • Für • Pour • Para: GN 1/1	62,00
2103145	Per • For • Für • Pour • Para: GN 2/1*	55,00



Traversino per bagno maria • Support for bain marie • Querstrebe für Bain-Marie • Traverse pour bain-marie
Larguero para baño maría

2014924	327x25	10,00
2014925	532x25	11,00



ELEMENTI NEUTRI

NEUTRAL UNITS • ARBEITSELEMENTE
ÉLÉMENTS NEUTRES • MUEBLES NEUTROS

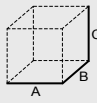
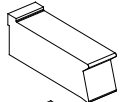
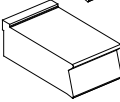
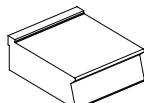
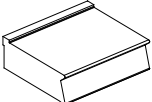
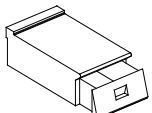
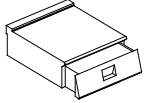
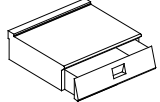
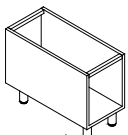
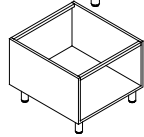
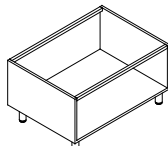
	CODICE	 (A x B x C) mm	VOL./PESO	PREZZO
	Code Kode Code Codigo		Vol./Weight Vol./Gewicht Vol./Poids Vol./Pesos	
			m³/kg	€
	EN710T	200x700x307	0,15/30	485,00
	EN720T	400x700x307	0,2/35	680,00
	EN730T	600x700x307	0,3/38	848,00
	EN740T	800x700x307	0,35/45	910,00
Con cassetto • With drawer • Mit Schublade • Avec tiroir • Con cajón				
	EN72CT	400x700x307		1.024,00
	EN73CT	600x700x307		1.185,00
	EN74CT	800x700x307		1.231,00
Base neutra • Base unit • Basiseinheit • Base neutre • Base neutra				
	BV720G	400x635x650		482,00
	BV740G	800x635x650		577,00
	BV760G	1200x635x650		666,00

ACCESSORI PER ELEMENTI NEUTRI

unika700
TOP

ACCESSORIES FOR NEUTRAL UNITS • ZUBEHÖR FÜR ARBEITSELEMENTE
ACCESSOIRES POUR ÉLÉMENTS NEUTRES • ACCESORIOS PARA MUEBLES NEUTROS

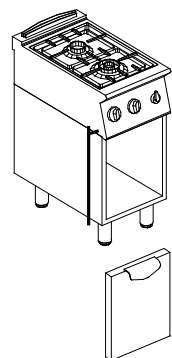

CODICE Code Kode Code Codigo	 (A x B x C) mm	PREZZO Price Preis Prix Precio €
	Rampa gas • Gas burner ramp • Gasrampe • Rampe gaz • Rampa gas	
2026093		79,00
	Porte • Doors • Flügeltüren • Portes • Puertas	
2016437		156,00

ACCESSORI PER CUCINE

ACCESSORIES FOR RANGES • ZUBEHÖR FÜR HERDE
ACCESSOIRES POUR FORNEAUX • ACCESORIOS PARA COCINA

Griglia in ghisa vetrificata monofuoco • Single-burner vitrified cast iron pan rest • Einflammen-Topfträger aus verglastem Gusseisen • Grille en fonte vitrifiée monofeu • Rejilla de hierro fundido vitrificada para quemador único



2016213	395x285	Non ordinabile per Linea Base • Not suitable for Linea Base Nicht geeignet für Linea Base • Pas adapté pour Linea Base No puedes pedir por Linea Base	127,00
----------------	---------	---	---------------



Griglia in ghisa monofuoco per Linea Base • Single-burner cast iron pan rest for Base Line • Einflammen-Topfträger für Basis-Linie • Grille en fonte monofeu pour la Ligne Base • Rejilla de hierro fundido con quemador único para la Línea Base

2021106	335x300		69,00
----------------	---------	--	--------------

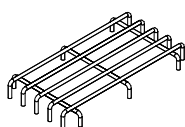

	Griglia in tondino • Rounded metal grill • Rundeisengitter • Grille en fil rond • Parrilla de varillas		
2020589		Non ordinabile per Linea Base • Not suitable for Linea Base Nicht geeignet für Linea Base • Pas adapté pour Linea Base No puedes pedir por Linea Base	253,00

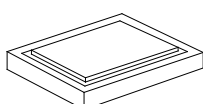

	Piastra liscie in Fe510 • Smooth Fe510 plate • Fe510 Platte glatt • Plaque lisse en Fe510 • Planchar de Fe510		
2016443	390x280	Non disponibile per la Comunità Europea • Not available for UE market	168,00

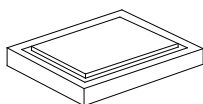

	Piastra liscia in acciaio inossidabile Duplex 2304 • Smooth Duplex 2304 stainless steel plate • Glatte Platte aus rostfreiem Stahl Duplex 2304 • Plaque lisse en acier inoxydable Duplex 2304 • Placa lisa de acero inoxidable Duplex 2304		
2016443X	390x280		255,00

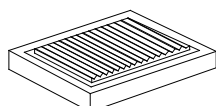

	Piastra rigata in Fe510 • Ribbed Fe510 plate • Fe510 Gusseisenplatte gerillt Plaque rajée en Fe510 • Planchar panuradas de Fe510		
2016444	390x280	Non disponibile per la Comunità Europea • Not available for UE market	184,00

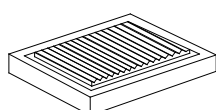

	Piastra rigata in acciaio inossidabile Duplex 2304 • Ribbed Duplex 2304 stainless steel plate • Gerillte Platte aus rostfreiem Stahl Duplex 2304 • Plaque nervurée en acier inoxydable Duplex 2304 • Placa acanalada de acero inoxidable Duplex 2304		
2016444X	390x280		270,00



ACCESSORI PER FRY TOP

ACCESSORIES FOR FRY TOP • ZUBEHÖR FÜR GAS-GRILLPLATTEN
ACCESSOIRES POUR GRILLADES GAZ • ACCESORIOS PARA FRY-TOP A GAS

CODICE Code Kode Code Codigo		VAC 230-1N 50/60 Hz	PREZZO Price Preis Prix Precio
	(A x B x C) mm	kW	€

Paraspruzzi • Splashguard • Spritzenschutz • Anti-éclaboussures • Antisalpicaduras

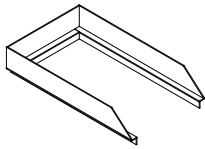

2024855	Per piastra unica 1/2 • For single plate 1/2 • Für Großfeldkochplatte 1/2 • Pour plaque unique 1/2 • Para placa única 1/2		168,00
2024234	Per piastra unica 1/1 • For single plate 1/1 • Für Großfeldkochplatte 1/1 • Pour plaque unique 1/1 • Para placa única 1/1		189,00

Raschietti per fry top • Scrapers for fry top • Kratzer für Grillplatten
Grattoir four grills • Raspador para fry top



7080100	Per piastra liscia • For smooth plate • Für glatte Platte • Pour plaque lisse • Para plancha lisa		58,00
7080101	Per piastra rigata • For ribbed plate • Für gerilte Platte • Pour plaque nervurée • Para plancha acanalada		79,00

ACCESSORI

ACCESSORIES • ZUBEHÖR • ACCESSOIRES • ACCESORIOS

Kit ruote • Kit castor • Rädersatz • Kit roulettes • Kit ruedas

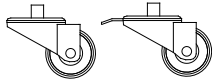

KITT348	4 ruote (2 autobloccanti) • 4 wheels (2 self-locking) • 4 Räder (2 selbstsichernd) 4 roues (2 autobloquantes) • 4 ruedas (2 autobloqueantes)		195,00
----------------	---	--	---------------

Elemento riscaldante ventilato per armadi • Ventilated cupboard base warmer • Umluft-Heizblock für Schrank • Corps de chauffe ventilé pour armoire • Elemento calentador ventilado para armarios

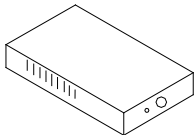

6000020	310x250x90	2	518,00
----------------	------------	---	---------------

ACCESSORI

ACCESSORIES • ZUBEHÖR • ACCESSOIRES • ACCESORIOS

unika700
TOP

unika700

CODICE Code Kode Code Codigo	PREZZO Price Preis Prix Precio
	€

Colonnina acqua • Water tap • Wasserhahn • Robinet de l'eau • Grifo de agua

7060077 510x725h

325,00



Zoccolatura • Plinth • Sockelblende • Socle • Zócalo

130,00 x ml

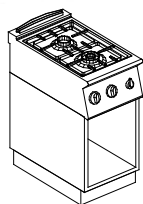

Kit supporto a ponte • Kit for bridge cooking suites • Satz für Brückenkochblöcke
Kit pour bloc de cuisson à pont • Kit soporte tipo puente

2020469 L = 400 mm

132,00

2020470 L = 600 mm

137,00

2020471 L = 800 mm

145,00

2020472 L = 1000 mm

150,00

2020473 L = 1200 mm

156,00

2020474 L = 1400 mm

168,00

2020475 L = 1600 mm

198,00

2020476 L = 1800 mm

243,00

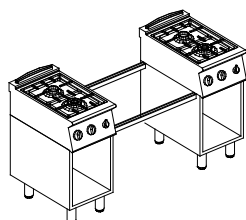

Corrimano • Trayslide • Tabletrutsche • Rampe à plateaux • Barra

168,00 x ml

2020477 L = 400 mm

68,00

2020478 L = 800 mm

135,00

2020479 L = 1200 mm

203,00

2020480 L = 1600 mm

270,00

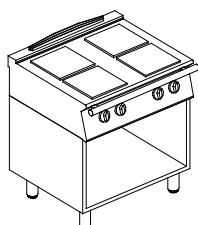

Corrimano portapiatti • Trayslide • Tabletrutsche • Rampe à plateaux • Barra para platos

194,00 x ml

2020481 L = 400 mm

78,00

2020482 L = 800 mm

156,00

2020483 L = 1200 mm

233,00

2020484 L = 1600 mm

312,00

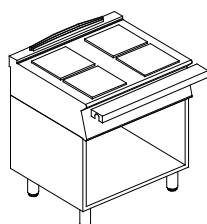

Struttura porta teglie • Tray holder structure • Backblechablage • Structure porte-plaque • Estructura para bandejas

2022727 L = 800 mm

2022728 L = 1200 mm

2022729 L = 1600 mm

2022730 L = 2000 mm

2022731 L = 2400 mm

2022732 L = 2800 mm

Su richiesta
On request
Auf Anfrage
Sur demande
Previa solicitud

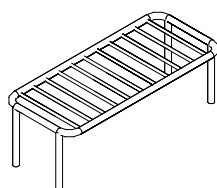

CODICE

Code
Kode
Code
Codigo

PREZZO

Price
Preis
Prix
Precio

€

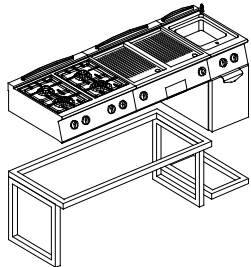

STL7

Struttura portante a telaio - 1 lato • Support frame - 1 sided
Untergestell - einseitig • Structure portante avec bâti - 1 côté
Estructura portante tipo bastidor - 1 lado

1.625,00 x ml

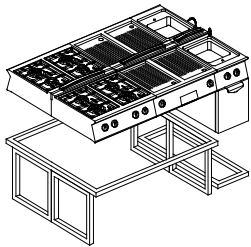

STLD7

Struttura portante a telaio - 2 lati • Support frame - 2 sided
Untergestell - zweiseitig • Structure portante avec bâti - 2 côtés
Estructura portante tipo bastidor - 2 lados

2.278,00 x ml

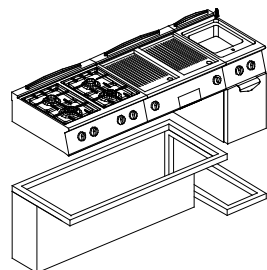

STL7P

Struttura portante a telaio con pannelli di tamponatura - 1 lato
Support frame with kick panels - 1 sided • Untergestell mit
Abschlusspaneelen - einseitig • Structure portante avec bâti et
panneaux de parement - 1 côté
Estructura portante tipo bastidor con paneles de cierre - 1 lado

2.148,00 x ml

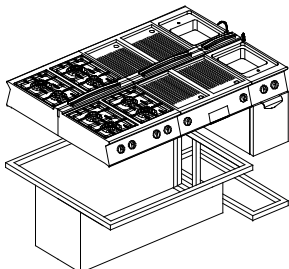

STLD7P

Struttura portante a telaio con pannelli di tamponatura - 2 lati
Support frame with kick panels - 2 sided • Untergestell mit
Abschlusspaneelen - zweiseitig • Structure portante avec bâti et
panneaux de parement - 2 côtés
Estructura portante tipo bastidor con paneles de cierre - 2 lados

3.059,00 x ml

unika900

PPC PRODOTTI PRONTA CONSEGNA

I prodotti contrassegnati con **PPC** sono disponibili alla spedizione in meno di 24h. • Products marked with **PPC** are available for shipment in less than 24 hours. • Mit **PPC** gekennzeichnete Produkte sind in weniger als 24 Stunden versandbereit. • Les produits marqués avec **PPC** sont disponibles pour l'expédition en moins de 24 heures. • Los productos marcados con **PPC** están disponibles para su envío en menos de 24 horas.



CPG926

CUOCIPASTA A GAS
GAS PASTA COOKER
GAS NUDELKOCHER
CUISSIÈURS À PÂTE À GAZ
CUECE-PASTAS GAS

CG940G / CG960G

CUCINE GAS
GAS RANGES
GASHERDE
FORNEAUX GAZ
COCINA A GAS

FG9117T (17 LT)

FRIGGITRICI GAS
GAS DEEP FAT FRYERS
GAS FRITEUSEN
FRITEUSES GAZ
FREIDORA A GAS

CPE926

CUOCIPASTA ELETTRICO
ELECTRIC PASTA COOKER
ELEKTRO NUDELKOCHER
CUISSIÈURS À PÂTE ÉLECTRIQUES
CUECE-PASTAS ELÉTRICOS

GIORIK
INNOVATIVE COOKING EQUIPMENT SINCE 1963

CUCINE A GAS A GIORNO E SU FORNO

GAS RANGES WITH AND WITHOUT OVEN • GASHERDE MIT UND OHNE BACKOFEN
FORNEAUX GAZ SANS ET AVEC FOUR • COCINAS A GAS

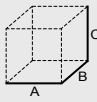
CODICE Code Kode Code Codigo	 (A x B x C) mm	VOL./PESO Vol./Weight Vol./Gewicht Vol./Poids Vol./Pesos m ³ /kg	GAS kW	VAC 230-1N 50/60 Hz kW	VAC 400-3N 50/60 Hz kW	PREZZO Price Preis Prix Precio €
--	---	--	-----------	---------------------------------	---------------------------------	---

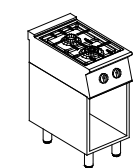

 **ECG920G** 400x900x900 0,6/70 9,5 **1.625,00**

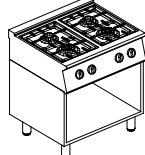

 **ECG940G** 800x900x900 1,1/115 19 **2.747,00**

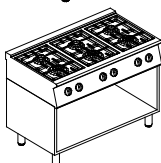

 **ECG960G** 1200x900x900 1,4/175 28,5 **3.498,00**

Fuochi su forno • Burners on oven • Flammen mit Ofen • Feux vifs sur four • Cocinas sobre horno



 **ECG940F** 800x900x900 1,1/170 27 **3.835,00**



ECG940E 800x900x900 1,1/170 19 6,2 **4.358,00**

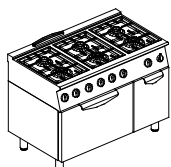



 **ECG960F** 1200x900x900 1,4/250 36,5 **5.082,00**

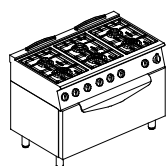

ECG960E 1200x900x900 1,4/250 28,5 6,2 **5.621,00**

Fuochi su maxi forno a gas • Burners on maxi gas oven • Flammen mit maxi Gasofen
Feux vifs sur four maxi gaz • Cocinas sobre maxi gas horno



 **ECG960H** 1200x900x900 1,4/250 38,5 **5.370,00**



ECG96EH 1200x900x900 1,4/250 28,5 9 **5.995,00**

CUCINE A GAS A GIORNO E SU FORNO







unika900

GAS RANGES WITH AND WITHOUT OVEN • GASHERDE MIT UND OHNE BACKOFEN
FORNEAUX GAZ SANS ET AVEC FOUR • COCINAS A GAS

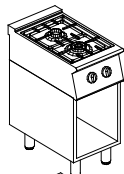

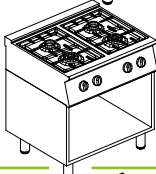

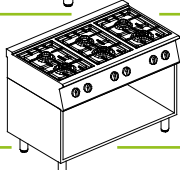

CODICE Code Kode Code Codigo	VOL./PESO Vol./Weight Vol./Gewicht Vol./Poids Vol./Pesos	GAS	VAC 230-1N 50/60 Hz	VAC 400-3N 50/60 Hz	PREZZO Price Preis Prix Precio
(A x B x C) mm	m ³ /kg	kW	kW	kW	€



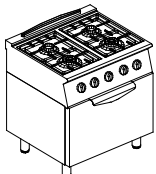



Griglie standard
Standard grids
Standardgitter
Grilles standard
Parrillas estándar

		CG920G	400x900x900	0,6/70	16		2.013,00
		CG940G	800x900x900	1,1/115	32		3.108,00
		CG960G	1200x900x900	1,4/175	48		4.228,00

Fuochi su forno • Burners on oven • Flammen mit Ofen • Feux vifs sur four • Cocinas sobre horno

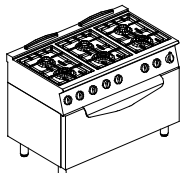
		CG940F	800x900x900	1,1/170	40		4.455,00
		CG940E	800x900x900	1,1/170	32	6,2	4.924,00
		CG960F	1200x900x900	1,4/250	56		5.833,00
		CG960E	1200x900x900	1,4/250	48	6,2	6.543,00

Fuochi su maxi forno • Burners on maxi oven • Flammen mit maxi Ofen
Feux vifs sur four maxi • Cocinas sobre maxi horno

		CG960H	1200x900x900	1,4/250	58		6.278,00
		CG96EH	1200x900x900	1,4/250	48	9	6.724,00



GAS RANGES WITH AND WITHOUT OVEN • GASHERDE MIT UND OHNE BACKOFEN
 FORNEAUX GAZ SANS ET AVEC FOUR • COCINAS A GAS

CODICE Code Kode Code Codigo	 (A x B x C) mm	VOL./PESO Vol./Weight Vol./Gewicht Vol./Poids Vol./Pesos	GAS	VAC 230-1N 50/60 Hz	VAC 400-3N 50/60 Hz	PREZZO Price Preis Prix Precio
		m³/kg	kW	kW	kW	€



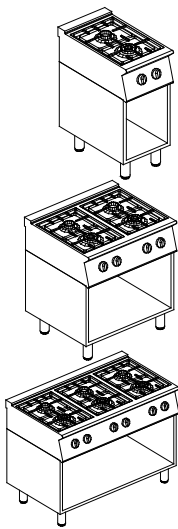



Griglie a filo piano
 Grids flush with top
 Flächenbündige Gitter
 Grilles à fleur du plan
 Parrillas a ras de cocina

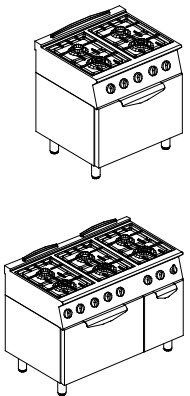

 CG92FG	400x900x900	0,6/70	16			2.409,00
 CG94FG	800x900x900	1,1/115	32			3.810,00
 CG96FG	1200x900x900	1,4/175	48			5.284,00

Fuochi su forno • Burners on oven • Flammen mit Ofen • Feux vifs sur four • Cocinas sobre horno



 CG94FF	800x900x900	1,1/170	40			5.196,00
 CG94FE	800x900x900	1,1/170	32		6,2	5.722,00
 CG96FF	1200x900x900	1,4/250	56			6.829,00
 CG96FE	1200x900x900	1,4/250	48		6,2	7.582,00

Fuochi su maxi forno a gas • Burners on maxi gas oven • Flammen mit maxi Gasofen
 Feux vifs sur four maxi gaz • Cocinas sobre maxi gas horno

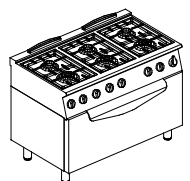

 CG96FH	1200x900x900	1,4/250	58			7.062,00
---	--------------	---------	----	--	--	-----------------

ACCESSORI

unika900

ACCESSORIES • ZUBEHÖR • ACCESSOIRES • ACCESORIOS

CODICE Code Kode Code Codigo	PREZZO Price Preis Prix Precio
--	--

€



Riduzione pentole per wok • Wok stand • Wokaufsatz für Gasherd • Réduction grilles pour wok
Reductor fogones para wok

2021656

495,00

Sistema carico acqua con scarico troppo pieno. Modifica da richiedere al momento dell'ordine • Water filling system with overflow pipe. Any change should be requested upon order • Wasserzulaufsystem mit Überlaufschutz. Jede Änderung muss bei der Bestellung angefordert werden • Système de remplissage eau avec trop plein d'évacuation. Modification à demander au moment de la commande • Sistema de entrada de agua con desagüe de desbordamiento. Solicitar modificación al efectuar el pedido

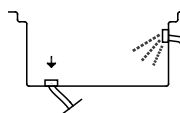

2020048 Per 2 fuochi • For 2 burners • Für 2 Brenner • Pour 2 feux • Para 2 quemadores **405,00**

2020049 Per 4 fuochi • For 4 burners • Für 4 Brenner • Pour 4 feux • Para 4 quemadores **509,00**

2020050 Per 6 fuochi • For 6 burners • Für 6 Brenner • Pour 6 feux • Para 6 quemadores **747,00**

Sistema carico acqua disponibile solo per griglie a filo piano • Water filling system available only for grids flush with top • Wasserzulaufsystem verfügbar nur für Flächenbündige Gitter • Système de remplissage disponible seulement pour grilles à fleur du plan • Sistema de entrada de agua disponible solamente para parrillas a ras de cocina

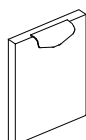

Porte • Doors • Flügeltüren • Portes • Puertas

2016437

156,00

unika900

LineaBase 900 CONFIGURAZIONE BRUCIATORI

CONFIGURATION BURNERS • KONFIGURATION BRENNER
CONFIGURATION BRÛLEURS • CONFIGURACION DE QUEMADORES

STANDARD

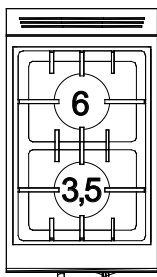

9,5 kW

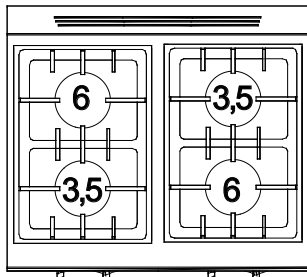

19 kW

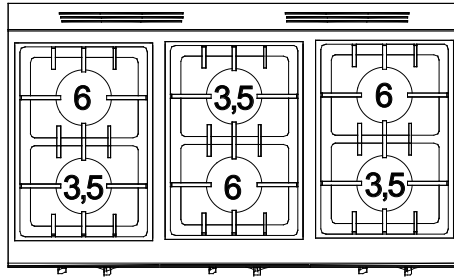

28,5 kW

unika900 CONFIGURAZIONE BRUCIATORI

CONFIGURATION BURNERS • KONFIGURATION BRENNER
CONFIGURATION BRÛLEURS • CONFIGURACION DE QUEMADORES

STANDARD

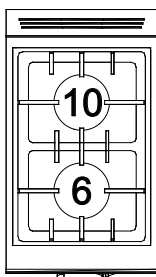

16 kW

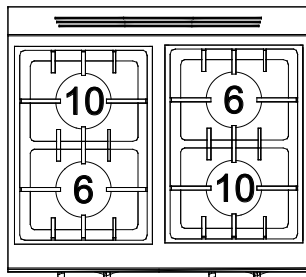

32 kW

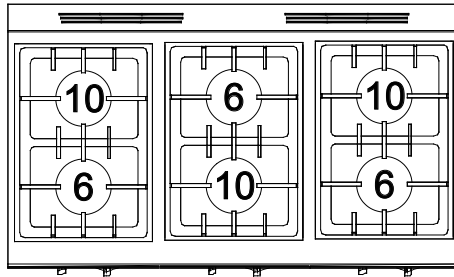

48 kW

Extra prezzo per configurazioni speciali

Extra price for special configurations • Extra Preis für Sonderkonfigurationen

Extra prix pour configurations spéciales • Extra precio para configuraciones especiales

20 kW

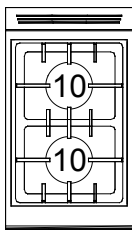

+116,00 €

36 kW

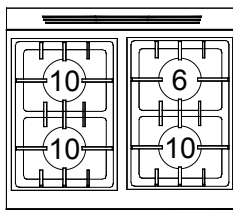

+116,00 €

40 kW

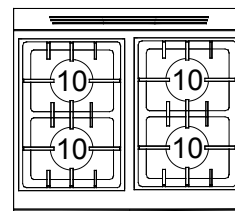

+233,00 €

52 kW

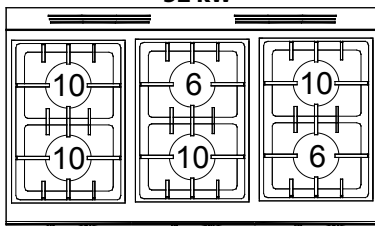

+116,00 €

60 kW

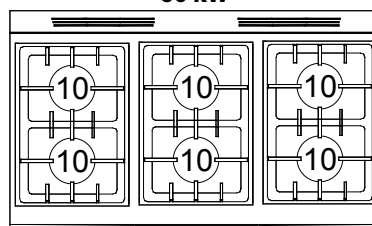

+349,00 €

CUCINE TUTTAPIASTRA

unika900

SOLID TOPS • GLÜHPLATTENHERDE
 CUISINIÈRES COUP DE FEU • PLACAS RADIANTES

CODICE Code Kode Code Codigo		VOL./PESO Vol./Weight Vol./Gewicht Vol./Poids Vol./Pesos	GAS	VAC		PREZZO Price Preis Prix Precio
				230-1N 50/60 Hz	400-3N 50/60 Hz	
	(A x B x C) mm	m³/kg	kW	kW	kW	€

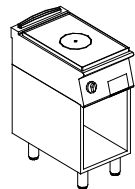

TG920G 400x900x900 0,6/90 7,5 **2.691,00**

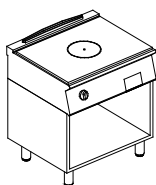

TG940G 800x900x900 1,1/105 15 **3.174,00**

Forno gas • Gas oven • Gas Backofen • Four à gaz • Horno a gas

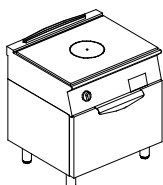

TG940F 800x900x900 1,1/190 23 **5.079,00**

Forno elettrico • Electric oven • Elektro Backofen • Four électrique • Horno eléctrico

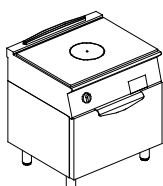

TG940E 800x900x900 1,1/190 15 6,2 **5.128,00**

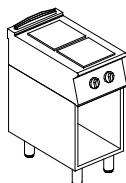

TE920G 400x900x900 0,6/90 6 **4.566,00**

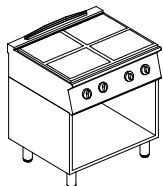

TE940G 800x900x900 1,1/140 12 **5.906,00**

Forno elettrico • Electric oven • Elektro Backofen • Four électrique • Horno eléctrico

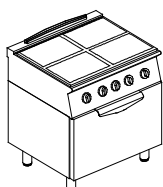

TE940E 800x900x900 1,1/190 18,2 **6.563,00**

ACCESSORI

ACCESSORIES • ZUBEHÖR • ACCESSOIRES • ACCESORIOS

Leverino • Lever • Eisen • Petit levier • Palanca



2019661

66,00

ELECTRIC RANGE WITH SQUARE PLATES • ELEKTROHERDE MIT VIERECKIGEN GUSSPLATTEN
 FORNEAUX ÉLECTRIQUES AVEC PLAQUES CARRÉES • COCINAS ELÉCTRICAS CON PLANCHAS CUADRADAS

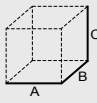
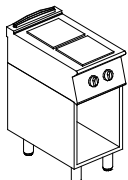
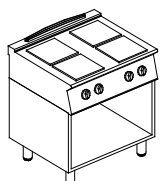
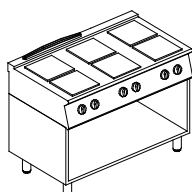
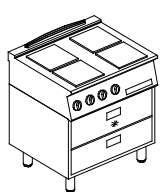
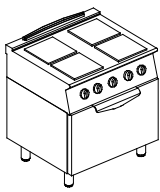
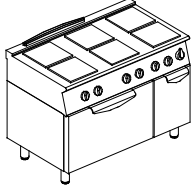
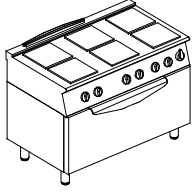
CODICE Code Kode Code Código		VOL./PESO Vol./Weight Vol./Gewicht Vol./Poids Vol./Pesos	GAS	VAC		PREZZO Price Preis Prix Precio
				230-1N 50/60 Hz	400-3N 50/60 Hz	
	(A x B x C) mm	m ³ /kg	kW	kW	kW	
	CE92QG	400x900x900 2x(300x300)	0,6/75		8	2.519,00
	CE94QG	800x900x900 4x(300x300)	1,1/115		16	4.261,00
	CE96QG	1200x900x900 6x(300x300)	1,3/160		24	5.672,00
Mantenitore • Holding • Warmhaltegeräte • Les fours de maintien • Mantenedores						
	CE94QGMC	800x900x900 4x(300x300)	1,1/115	0,9 *	16 **	7.176,00
Forno elettrico • Electric oven • Elektro Backofen • Four électrique • Horno eléctrico						
	CE94QE	800x900x900 4x(300x300)	1,1/155		22,2	5.913,00
	CE96QE	1200x900x900 6x(300x300)	1,3/160		30,2	7.531,00
	CE96QH	1200x900x900 6x(300x300)	1,3/160		33	7.686,00

 * Potenza mantenitore • Holding power • Maintainer Macht • Puissance mainteneur • Potencia mantenedor
 ** Potenza piastre • Plates Power • Kochplatten Macht • Puissance de plaques de cuisson • Potencia placas

CUCINE VETROCERAMICA

unika900

RANGES CERAMIC GLASS • HERDE GLASKERAMIK • PLAQUES DE CUISSON EN VITROCÉRAMIQUE
COCINAS VETROCERAMICA

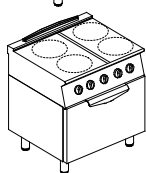
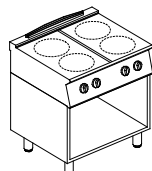
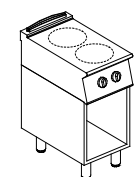

CODICE Code Kode Code Codigo	 (A x B x C) mm	VOL./PESO Vol./Weight Vol./Gewicht Vol./Poids Vol./Pesos m ³ /kg	GAS kW	VAC	VAC	PREZZO Price Preis Prix Precio €
				230-1N 50/60 Hz kW	400-3N 50/60 Hz kW	
CV920G	400x900x900 2x ø270	0,6/75			5,5	2.855,00
CV940G	800x900x900 4x ø270	1,1/115			11	4.492,00
Forno elettrico • Electric oven • Elektro Backofen • Four électrique • Horno eléctrico						
CV940E	800x900x900 4x ø270	1,1/155			17,2	6.060,00

CUCINA A INDUZIONE

INDUCTION RANGES • INDUKTIONSHERDE • PLAQUES DE CUISSON À INDUCTION
COCINAS ELECTRICAS A INDUCCIÓN

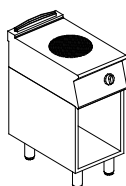
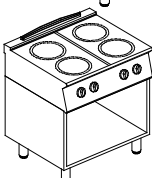
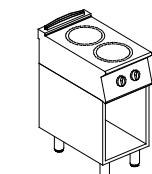

Piastre induzione • Induction rings • Induktionsplatten • Foyers à induction • Placas de induccion						
CI920G	400x900x900 2x ø270	0,6/75			10	9.427,00
CI940G	800x900x900 4x ø270	1,1/115			20	16.704,00
Wok induzione • Induction wok • Induktion-Wok • Wok à induction • Placas de induccion Wok						
CW920G	400x900x900 1x ø300	0,6/75			5	7.588,00
PIASTRE INDUZIONE TUTTO PIANO • Even heating induction plates • Durchgehende Induktionskochfläche • Plans à induction sur tout le plan • Cocinas de inducción entera						
CI92TG	400x900x900	0,6/75			14	13.400,00
CI94TG	800x900x900	1,1/115			28	23.250,00

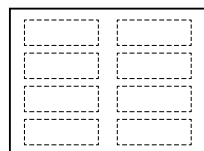

ACCESSORI

ACCESSORIES • ZUBEHÖR • ACCESSOIRES • ACCESORIOS



Pentola per wok • Pan for wok • Topf für Wok • Casserolle pour wok • Olla para wok						
5920010	Dim. ø360x102h mm					403,00

MULTI COOKING BRATT PANS • ELEKTRO MULTI-BRÄTER
 MULTI-SAUTEUSE • SARTEN MULTIPLIO

CODICE Code Kode Code Codigo		VOL./PESO Vol./Weight Vol./Gewicht Vol./Poids Vol./Pesos	VAC		CAPACITA' Capacity Inhalt Capacité Capacidad	PREZZO Price Preis Prix Precio
			230-1N 50/60 Hz	400-3N 50/60 Hz		
	(A x B x C) mm	m ³ /kg			Lt.	€

CM920G

 400x900x900
GN 1/1

0,6/75

5,1

15

3.804,00

CM940G

 800x900x900
GN 2/1

1,1/115

10,2

30

5.419,00
SCALDAPATATE

CHIPS SCUTTLES • POMMES FRITES-WÄRMER • BAC DE SALAGE • CALIENTAPATATAS

CODICE Code Kode Code Codigo		VOL./PESO Vol./Weight Vol./Gewicht Vol./Poids Vol./Pesos	VAC		CAPACITA' Capacity Inhalt Capacité Capacidad	PREZZO Price Preis Prix Precio
			230-1N 50/60 Hz	400-3N 50/60 Hz		
	(A x B x C) mm	m ³ /kg			Lt.	€

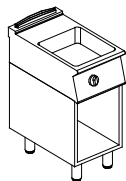
SP920G

 400x900x900
GN 1/1

0,6/55

1,38

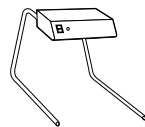
2.489,00

LSR4911

400x390x410



0,12/13

0,75

748,00

FRY TOP A GAS

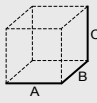
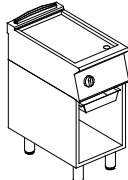
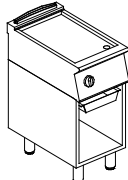
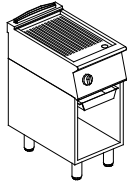
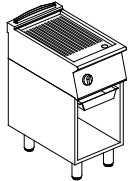
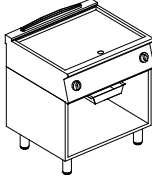
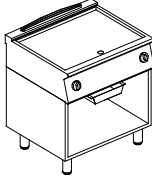
GAS GRIDDLE PLATES • GAS-GRILLPLATTEN
GRILLADES GAZ • FRY-TOP A GAS

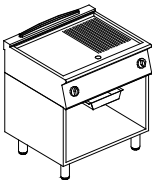
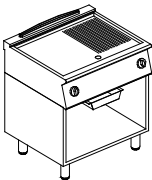
CODICE Code Kode Code Codigo		VOL./PESO Vol./Weight Vol./Gewicht Vol./Poids Vol./Pesos	GAS	VAC 230-1N 50/60 Hz	VAC 400-3N 50/60 Hz	PREZZO Price Preis Prix Precio
Liscio • Smooth • Glatt • Lisse • Liso						
 FLG92GF	400x900x900	0,6/95	9			2.251,00
Non disponibile per la Comunità Europea • Not available for UE market						
 FLG92GCRX	400x900x900	0,6/95	9			2.671,00
Termostato • Thermostated • Thermostate • Thermostatisiert • Termostatizado						
Rigato • Ribbed • Gerillt • Nervuré • Acanalado						
 FRG92GF	400x900x900	0,6/95	9			2.400,00
Non disponibile per la Comunità Europea • Not available for UE market						
 FRG92GCRX	400x900x900	0,6/95	9			2.901,00
Termostato • Thermostated • Thermostate • Thermostatisiert • Termostatizado						
Liscio • Smooth • Glatt • Lisse • Liso						
 FLG941GF	800x900x900	0,9/175	18			3.349,00
Non disponibile per la Comunità Europea • Not available for UE market						
 FLG941GCRX	800x900x900	0,9/175	18			3.897,00
Termostato • Thermostated • Thermostate • Thermostatisiert • Termostatizado						
Rigato • Ribbed • Gerillt • Nervuré • Acanalado						
 FRG941GF	800x900x900	0,9/175	18			3.772,00
Non disponibile per la Comunità Europea • Not available for UE market						
 FRG941GCRX	800x900x900	0,9/175	18			4.504,00
Termostato • Thermostated • Thermostate • Thermostatisiert • Termostatizado						
Liscio-Rigato • Smooth-Ribbed • Glatt-Gerillt • Lisse-Nervuré • Liso-Acanalado						
 FMG941GF	800x900x900	0,9/175	18			3.617,00
Non disponibile per la Comunità Europea • Not available for UE market						
 FMG941GCRX	800x900x900	0,9/175	18			4.236,00
Termostato • Thermostated • Thermostate • Thermostatisiert • Termostatizado						



F Piastra in ferro • Mild iron plate • Platte aus Eisen • Plaque en fer • Placa de hierro
Non disponibile per la comunità Europea • Not available for UE market
• Nicht erhältlich für die Europäische Gemeinschaft • Non disponible pour la Communauté européenne • No disponible para la Comunidad europea

CRX Piastra in acciaio spessore 15 mm con finitura cromata satinata
Conforme al regolamento CE 1935/2004 riguardante materiali e oggetti a contatto con gli alimenti. Il materiale è antiaderente e garantisce resistenza alla corrosione e ai graffi. • Steel Chrome-plated satin finish, 15 mm thickness. In compliance with UE Regulation 1935/2004 on materials and articles in contact with food. The material is non-stick and guarantees resistance to corrosion and scratches. • Stahl Verchromt satiniert, 15 mm dick. • Acier chromé satiné, épaisseur 15 mm. • Acero Cromado satinado, 15 mm de espesor.

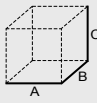
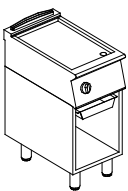
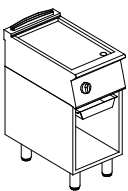
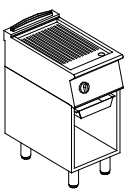
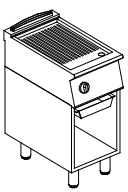
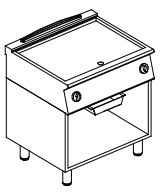
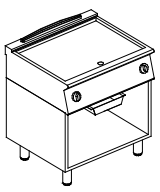

unika900 FRY TOP ELETTRICI

ELECTRIC GRIDDLE PLATES • ELEKTRO-GRILLPLATTEN
GRILLADES ÉLECTRIQUES • FRY-TOP ELÉCTRICOS

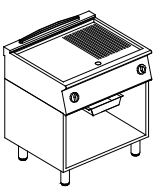
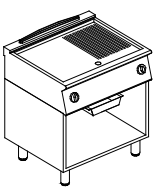
CODICE Code Kode Code Codigo	 (A x B x C) mm	VOL./PESO Vol./Weight Vol./Gewicht Vol./Poids Vol./Pesos m ³ /kg	GAS kW	VAC 230-1N 50/60 Hz kW	VAC 400-3N 50/60 Hz kW	PREZZO Price Preis Prix Precio €
Liscio • Smooth • Glatt • Lisse • Liso						
 FLE92GF	400x900x900	0,6/95			8	2.450,00
Non disponibile per la Comunità Europea • Not available for UE market						
 FLE92GCRX	400x900x900	0,6/95			8	2.718,00
Rigato • Ribbed • Gerillt • Nervuré • Acanalado						
 FRE92GF	400x900x900	0,6/95			8	2.576,00
Non disponibile per la Comunità Europea • Not available for UE market						
 FRE92GCRX	400x900x900	0,6/95			8	2.931,00
Liscio • Smooth • Glatt • Lisse • Liso						
 FLE941GF	800x900x900	0,9/175			16	3.665,00
Non disponibile per la Comunità Europea • Not available for UE market						
 FLE941GCRX	800x900x900	0,9/175			16	4.144,00
Rigato • Ribbed • Gerillt • Nervuré • Acanalado						
 FRE941GF	800x900x900	0,9/175			16	4.028,00
Non disponibile per la Comunità Europea • Not available for UE market						
 FRE941GCRX	800x900x900	0,9/175			16	4.506,00
Liscio-Rigato • Smooth-Ribbed • Glatt-Gerillt • Lisse-Nervuré • Liso-Acanalado						
 FME941GF	800x900x900	0,9/175			16	3.877,00
Non disponibile per la Comunità Europea • Not available for UE market						
 FME941GCRX	800x900x900	0,9/175			16	4.314,00

F Piastra in ferro • Mild iron plate • Platte aus Eisen • Plaque en fer • Placa de hierro
Non disponibile per la comunità Europea • Not available for UE market
• Nicht erhältlich für die Europäische Gemeinschaft • Non disponible pour la Communauté européenne • No disponible para la Comunidad europea

CRX Piastra in acciaio spessore 15 mm con finitura cromata satinata
Conforme al regolamento CE 1935/2004 riguardante materiali e oggetti a contatto con gli alimenti. Il materiale è antiaderente e garantisce resistenza alla corrosione e ai graffi. • Steel Chrome-plated satin finish, 15 mm thickness. In compliance with UE Regulation 1935/2004 on materials and articles in contact with food. The material is non-stick and guarantees resistance to corrosion and scratches. • Stahl Verchromt satiniert, 15 mm dick. • Acier chromé satiné, épaisseur 15 mm. • Acero Cromado satinado, 15 mm de espesor.

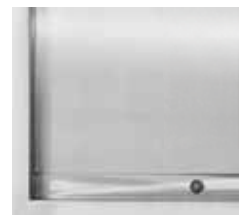

AQUA-GRILL A GAS

GAS STEAMGRILL • DAMPF GRILL, GAS AUSFÜHRUNG • GRILLE VAPEUR À GAZ
VAPOR BARBACOA DE GAS

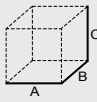
CODICE Code Kode Code Codigo	 (A x B x C) mm	VOL./PESO Vol./Weight Vol./Gewicht Vol./Poids Vol./Pesos	GAS	VAC 230-1N 50/60 Hz	VAC 400-3N 50/60 Hz	PREZZO Price Preis Prix Precio
		m ³ /kg	kW	kW	kW	€

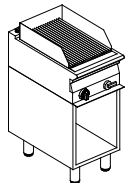

GL92GV 400x900x900 0,6/90 11 **3.062,00**

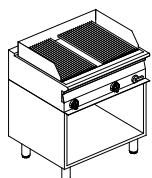

GL94GV 800x900x900 1,1/140 22 **4.527,00**

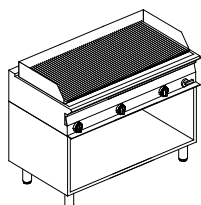

GL96GV 1200x900x900 1,4/170 33 **5.992,00**

AQUA-GRILL ELETTRICI

ELECTRIC STEAMGRILL • DAMPF GRILL, ELEKTROAUSFÜHRUNG • GRILLE VAPEUR ÉLECTRIQUE
VAPOR BARBACOA ELÉCTRICO

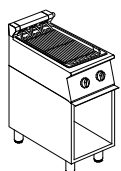

GL92GE 400x900x900 0,6/70 5,4 **3.403,00**



GL94GE 800x900x900 1,1/90 10,8 **4.988,00**

LAVA ROCK GRILLS • LAVASTEINGRILLS
GRILLES A PIERRE VOLCANIQUE • BARBACOA DE PIEDRA LÁVICA

CODICE		VOL./PESO	GAS	VAC	VAC	PREZZO
Code Kode Code Codigo		Vol./Weight Vol./Gewicht Vol./Poids Vol./Pesos		230-1N 50/60 Hz	400-3N 50/60 Hz	Price Preis Prix Precio
	(A x B x C) mm	m ³ /kg	kW	kW	kW	€

Griglia per carne • Grill for meat • Fleischrost • Grille pour viande • Rejilla para carne



GL920GC 400x900x900 0,6/70 15 **2.768,00**

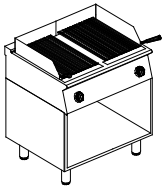

GL940GC 800x900x900 1,1/130 30 **4.067,00**

ACCESSORI

ACCESSORIES • ZUBEHÖR • ACCESSOIRES • ACCESORIOS

Griglia per pesce • Grill for fish • Fischrost • Grille pour poisson • Rejilla para pescado

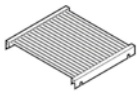

2009849 Per • For • Für • Pour • Para: GL920GC **267,00**

2009861 Per • For • Für • Pour • Para: GL940GC (2 pz. • 2 pcs • 2 st. • 2 pcs • 2 und) **254,00**

Griglia per carne • Grill for meat • Fleischrost • Grille pour viande • Rejilla para carne



2011346 Per • For • Für • Pour • Para: GL920GC **287,00**

2011372 Per • For • Für • Pour • Para: GL940GC (2 pz. • 2 pcs • 2 st. • 2 pcs • 2 und) **273,00**

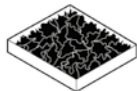

Lava vulcanica • Lava rock • Lavastein • Lave volcanique • Lava volcànica

7090123 Confezione • Bag • Packung • Emballage • Envase: **7kg** **39,00**

BAGNO MARIA

unika900

BAIN MARIES • BAIN-MARIES • BAIN-MARIE • BAÑO MARÍA

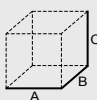
CODICE Code Kode Code Codigo	 (A x B x C) mm	VOL./PESO Vol./Weight Vol./Gewicht Vol./Poids Vol./Pesos m³/kg	GAS kW	VAC 230-1N 50/60 Hz kW	VAC 400-3N 50/60 Hz kW	PREZZO Price Preis Prix Precio €
--	---	---	-----------	---------------------------------	---------------------------------	---

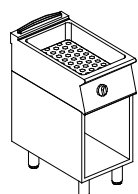

 BM920E GN 1/1+1/3	400x900x900	0,6/50		1,65		2.124,00
---	-------------	--------	--	------	--	-----------------



 BM940E GN 2/1+2GN1/3	800x900x900	1,1/65		3,3		2.962,00
--	-------------	--------	--	-----	--	-----------------

I prezzi dei bagnomaria **NON COMPRENDONO I CESTELLI** • The **BASKETS ARE NOT INCLUDED** in the price of bain maries • Die Preise der Bain Maries **ENTHALTEN KEINE KÖRBE** • Les prix des bain marie **NE COMPRENENT PAS LES PANIERS** • Los precios de los baño maría **NO INCLUYEN LOS CESTOS**.

ACCESSORI

ACCESSORIES • ZUBEHÖR • ACCESSOIRES • ACCESORIOS

Bacinelle • Basins • Behälter • Bacs • Recipientes

2103135	GN 1/4 H150	55,00
2103142	GN 1/3 H150	51,00
2103080	GN 1/2 H150	72,00
2103107	GN 2/3 H150	89,00
2103134	GN 1/1 H150	108,00
2103144	GN 2/1 H150	184,00



Coperchi • Lids • Deckel • Couvercles • Tapas

2103202	Per • For • Für • Pour • Para: GN 1/4	23,00
2103077	Per • For • Für • Pour • Para: GN 1/2	21,00
2103201	Per • For • Für • Pour • Para: GN 2/3	39,00
2103203	Per • For • Für • Pour • Para: GN 1/3	21,00
2103106	Per • For • Für • Pour • Para: GN 1/1	62,00
2103145	Per • For • Für • Pour • Para: GN 2/1	55,00



Traversino per bagno maria • Support for bain marie • Querstrebe für Bain-Marie • Traverse pour bain-marie
Larguero para baño maría





2014924	mm 327x25	10,00
2014927	mm 708x25	11,00

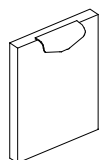

Porte • Doors • Flügeltüren • Portes • Puertas

2026529	Modulo 300 • Module 300 • Modul 300 • Module 300 • Mòdulo 300	151,00
2016437	Modulo 400 • Module 400 • Modul 400 • Module 400 • Mòdulo 400	156,00

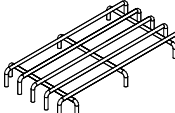
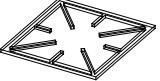
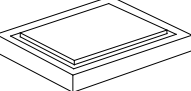
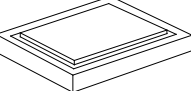
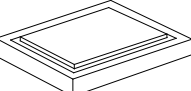
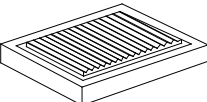
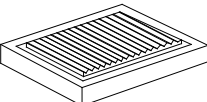

CODICE		PREZZO
Code		Price
Kode		Preis
Code		Prix
Codigo		Precio
		€
	<p>Griglia in ghisa vetrificata monofuoco • Single-burner vitrified cast iron pan rest • Einflammen-Topfträger aus verglastem Gusseisen • Grille en fonte vitrifiée monofeu • Rejilla de hierro fundido vitrificada para quemador único</p> <p>Non ordinabile per Linea Base • Not available for Linea Base • Nicht verfügar für Linea Base • Non disponibile pour Linea Base • No disponible para Linea Base</p>	<p>2016194 394x371 145,00</p>
	<p>Griglia in ghisa monofuoco per Linea Base • Single-burner cast iron pan rest for Base Line • Einflammen-Topfträger für Basis-Linie • Grille en fonte monofeu pour la Ligne Base • Rejilla de hierro fundido con quemador único para la Línea Base</p>	<p>2022577 360x360 72,00</p>
	<p>Griglia in tondino • Rounded metal grill • Rundeisengitter • Grille en fil rond • Parrilla de varillas</p> <p>Non ordinabile per Linea Base • Not available for Linea Base • Nicht verfügar für Linea Base • Non disponibile pour Linea Base • No disponible para Linea Base</p>	<p>2019841 273,00</p>
	<p>Griglie a filo piano (non ordinabile per linea base) • Grids flush with top • Flächenbündige Gitter • Grilles à fleur du plan • Parrillas a ras de cocina</p>	<p>2020491 INOX 689,00</p>
	<p>2019054 GHISA • Cast iron • Gusseisen • Fonte • Hierro fundido 68,00</p>	
	<p>Piastra liscia in Fe510 • Smooth Fe510 plate • Fe510 Platte glatt Plaque lisse en Fe510 • Planchar de Fe510</p> <p>2020748 390x360 189,00</p> <p><small>Non disponibile per la Comunità Europea • Not available for UE market</small></p>	
	<p>Piastra liscia in acciaio inossidabile Duplex 2304 • Smooth Duplex 2304 stainless steel plate • Glatte Platte aus rostfreiem Stahl Duplex 2304 • Plaque lisse en acier inoxydable Duplex 2304 • Placa lisa de acero inoxidable Duplex 2304</p> <p>2020748X 390x280 282,00</p>	
	<p>Piastra rigata in Fe510 • Ribbed Fe510 plate • Fe510 Gusseisenplatte gerillt • Plaque rajée en Fe510 • Planchar panuradas de Fe510</p> <p>2020749 390x360 202,00</p> <p><small>Non disponibile per la Comunità Europea • Not available for UE market</small></p>	
	<p>Piastra rigata in acciaio inossidabile Duplex 2304 • Ribbed Duplex 2304 stainless steel plate • Gerillte Platte aus rostfreiem Stahl Duplex 2304 • Plaque nervurée en acier inoxydable Duplex 2304 • Placa acanalada de acero inoxidable Duplex 2304</p> <p>2020749X 390x280 296,00</p>	
	<p>Griglie forno in acciaio • Chrome-plated steel grids for oven • Verchromter Stahl Grill Grille four chromée • Revillas cromada</p>	<p>2016438 GN 2/1 84,00</p>
	<p>2016439 930x650 Per forno Maxi • For Maxi Oven • Für Maxi Ofen Pour Four Maxi • Para Horno Maxi 84,00</p>	

ACCESSORI PER FRY TOP

unika900



ACCESSORIES FOR FRY TOP • ZUBEHÖR FÜR GRILLPLATTEN • ACCESSOIRES POUR GRILLADES
ACCESORIOS PARA FRY-TOP

CODICE Code Kode Code Codigo		PREZZO Price Preis Prix Precio	
€			
Paraspruzzi • Splashguard • Spritzenschutz • Anti-éclaboussures • Antisalpicaduras			
	2026876	Per piastra unica 1/2 • For single plate 1/2 • Für Großfeldkochplatte 1/2 Pour plaque unique 1/2 • Para placa única 1/2	197,00
	2026077	Per piastra unica 1/1 • For single plate 1/1 • Für Großfeldkochplatte 1/1 Pour plaque unique 1/1 • Para placa única 1/1	220,00
Raschietti per fry top • Scrapers for fry top • Kratzer für Grillplatten Grattoir four grills • Raspador para fry top			
	7080100	Per piastra liscia • For smooth plate • Für glatte Platte Pour plaque lisse • Para plancha lisa	58,00
	7080101	Per piastra rigata • For ribbed plate • Für gerillte Platte Pour plaque nervurée • Para plancha acanalada	79,00

unika900

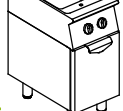

GAS AND ELECTRIC PASTA COOKER • ELEKTRO UND GAS NUDELKOCHER
 CUISIÈURS À PÂTE À GAZ ET ÉLECTRIQUES • CUECE-PASTAS GAS Y ELÉCTRICOS

CODICE Code Kode Code Codigo	 (A x B x C) mm	VOL./PESO Vol./Weight Vol./Gewicht Vol./Poids Vol./Pesos	GAS	VAC 400-3N 50/60 Hz	CAPACITÀ Capacity Inhalt Capacité Capacidad	PREZZO Price Preis Prix Precio
		m³/kg	kW	kW	Lt.	€

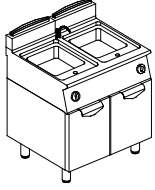
		CPG926	400x900x900	0,8/75	15	40	3.348,00
---	---	---------------	-------------	--------	----	----	-----------------

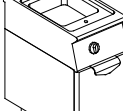

	CPG946	800x900x900	1,6/115	30	40 + 40	5.521,00
---	---------------	-------------	---------	----	---------	-----------------

		CPE926	400x900x900	0,8/65	9	40	3.172,00
--	---	---------------	-------------	--------	---	----	-----------------

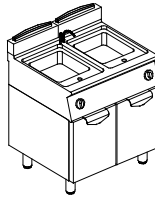

	CPE946	800x900x900	1,6/100	18	40 + 40	5.146,00
---	---------------	-------------	---------	----	---------	-----------------

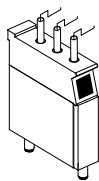

Modulo alzacestelli • Basket lifter • Korbhebersystem
 Module pour le relevage • Modulo levanta cestos automático

MAC90	150x900x900	4.229,00
--------------	-------------	-----------------

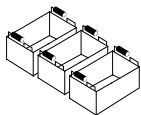

Kit 3 cestelli GNI/3 per MAC90 • Kit 3 baskets GNI/3 for MAC90 • Kit 3 Körbe GNI/3 für MAC90 •
 Kit 3 paniers GNI/3 pour MAC90 • Kit 3 cestos GNI/3 para MAC90

2024551K	290x160x170	512,00
-----------------	-------------	---------------

I prezzi dei cuocipasta **NON COMPRENDONO I CESTELLI** • The **BASKETS ARE NOT INCLUDED** in the price of pasta cookers •
 Die Preise der Nudelkochern **ENTHALTEN KEINE KÖRBE** • Les prix des cuiseurs à pâtes **NE COMPRENNENT PAS LES PANIERS** •
 Los precios de los cuecepastas **NO INCLUYEN LOS CESTOS**.

ACCESSORI PER CUOCIPASTA

unika900

ACCESSORIES FOR PASTA BOILERS • NUDELKOCHERZUBEHÖR
ACCESSOIRES POUR CUISEUR À PÂTES • ACCESORIOS PARA CUECE-PASTAS

CODICE	PREZZO
Code	Price
Kode	Preis
Code	Prix
Código	Precio
	€

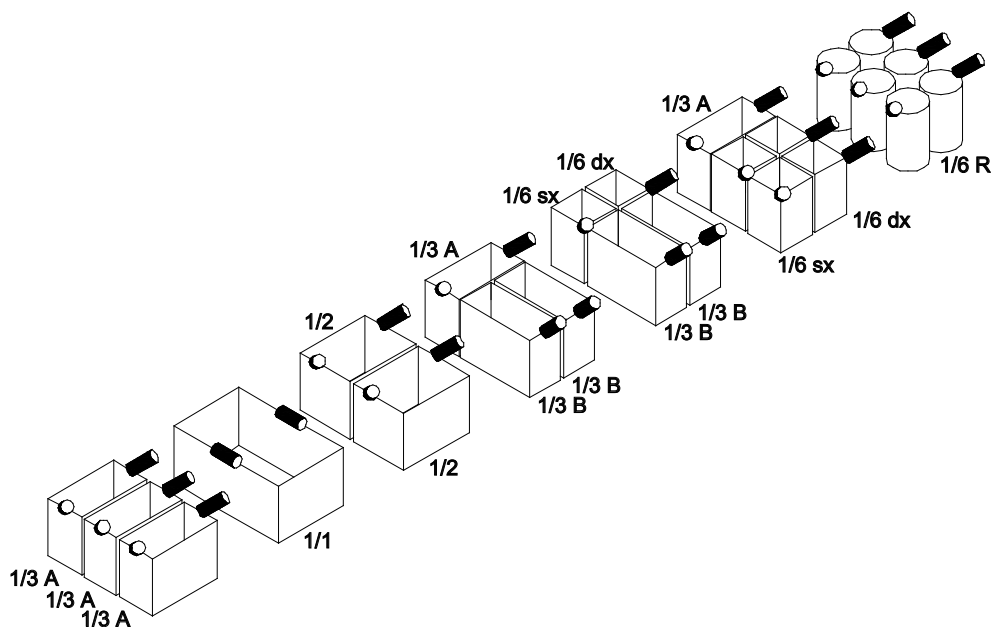

Cestelli • Baskets • Körbe • Paniers • Cestos

2101603	1/1 GN	mm 300x486x215H	260,00
2003074	1/2 GN	mm 295x242x215H	168,00
2003075	2/3 GN	mm 298x334x215H	168,00
2003046	1/3 GN (A)	mm 290x160x215H	132,00
2003077	1/3 GN (B)	mm 296x143x215H	137,00
2003045	1/6 GN (dx)	mm 163x143x215H	106,00
2003047	1/6 GN (sx)	mm 163x143x215H	106,00
2003080	1/6 GN (R)	Ø mm 152x215H	100,00
2003050	1/3 GN (C)	mm 165x295x215H	152,00

Coperchi per cuocipasta • Lids for pasta cooker • Deckel für Nudelkocher
Couvercle pour cuiseurs à pâtes • Tapa para cuece-pastas





2004152	1 x GN 1/1		66,00
----------------	------------	--	--------------

unika900

unika900 FRIGGITRICI GAS

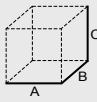
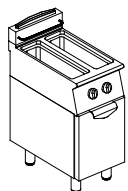
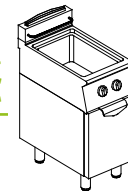
GAS DEEP FAT FRYERS • GAS FRITEUSEN
FRITEUSES GAZ • FREIDORAS A GAS

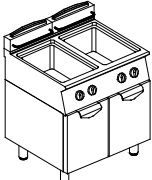
CODICE Code Kode Code Codigo		VOL./PESO Vol./Weight Vol./Gewicht Vol./Poids Vol./Pesos	GAS	VAC 230-1N 50/60 Hz	CAPACITÀ Capacity Inhalt Capacité Capacidad	PREZZO Price Preis Prix Precio
 FG9207T	400x900x900	0,8/88	12	0,2	8 + 8	4.311,00
FG9207MT	400x900x900	0,8/88	12	0,2	8 + 8	5.202,00
 FG9113T	400x900x900	0,8/70	11,5	0,1	13	3.182,00
 FG9117T	400x900x900	0,8/78	16,5	0,1	17	3.191,00
FG9113MT	400x900x900	0,8/70	11,5	0,1	13	3.635,00
FG9117MT	400x900x900	0,8/78	16,5	0,1	17	3.888,00
 FG9213T	800x900x900	1,6/140	23	0,2	13 + 13	5.239,00
FG9217T	800x900x900	1,6/145	33	0,2	17 + 17	5.749,00
FG9213MT	800x900x900	1,6/140	23	0,2	13 + 13	6.118,00
FG9217MT	800x900x900	1,6/145	33	0,2	17 + 17	6.844,00



...M

ELECTRONIC
MELTING CONTROL

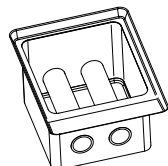











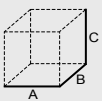
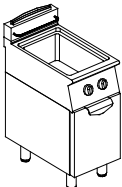

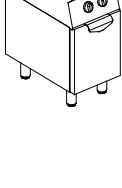



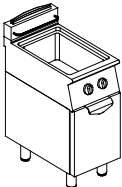

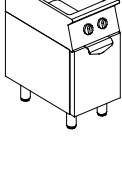

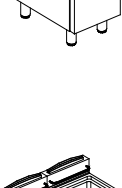
Scambiatori di calore INTERNI alla vasca
INTERNAL heat exchangers
Warmetauschern INNERHALB der Becken
Échangeurs de chaleur INTERNES à la cuve
Intercambiadores de calor ENTRE de la cuba

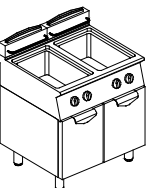
I prezzi sono **INCLUSIVI DEI CESTI** e di una vasca raccogli olio con filtro • Prices **INCLUDE BASKETS** and one oil draining tank with filter • Preise **ENTHALTEN KÖRBE** und eine Ölsammelwanne mit Filter • Les prix **COMPRENNENT LES PANIERS** et un bac recueil huile • Los precios **INCLUYEN LOS CESTOS** y una cuba recoge aceite con filtro.

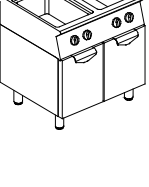
FRIGGITRICI GAS

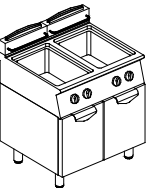
unika900

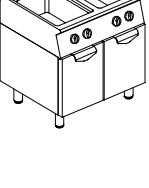
GAS DEEP FAT FRYERS • GAS FRITEUSEN
FRITEUSES GAZ • FREIDORAS A GAS

CODICE Code Kode Code Codigo		VOL./PESO Vol./Weight Vol./Gewicht Vol./Poids Vol./Pesos	GAS	VAC 230-1N 50/60 Hz	CAPACITÀ Capacity Inhalt Capacité Capacidad	PREZZO Price Preis Prix Precio
  FG9413P	400x900x900	0,8/70	12	0,1	13	3.247,00
  FG9417P	400x900x900	0,8/78	16	0,1	17	3.456,00
  FG9421P	400x900x900	0,8/78	20	0,1	21	3.558,00
  FG9413MP	400x900x900	0,8/70	12	0,2	13	3.842,00
  FG9417MP	400x900x900	0,8/78	16	0,2	17	4.034,00
  FG9421MP	400x900x900	0,8/78	20	0,2	21	4.099,00
  FG9817P	800x900x900	1,6/145	33	0,2	17 + 17	6.106,00
  FG9821P	800x900x900	1,6/145	38	0,2	21 + 21	6.607,00
  FG9817MP	800x900x900	1,6/145	33	0,2	17 + 17	7.061,00
  FG9821MP	800x900x900	1,6/145	38	0,2	21 + 21	7.574,00

unika900



...M

ELECTRONIC
MELTING CONTROL

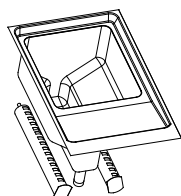

Scambiatori di calore ESTERNI alla vasca
EXTERNAL heat exchangers
Wärmetauschern AUßERHALB der Becken
Échangeurs de chaleur EXTERNES à la cuve
Intercambiadores de calor EXTERIORES a la cuba

I prezzi sono **INCLUSIVI DEI CESTI** e di una vasca raccogli olio con filtro • Prices **INCLUDE BASKETS** and one oil draining tank with filter • Preise **ENTHALTEN KÖRBE** und eine Ölsammelwanne mit Filter • Les prix **COMPRENENT LES PANIERS** et un bac recueil huile • Los precios **INCLUYEN LOS CESTOS** y una cuba recoge aceite con filtro.

CE IMQ

KOREA GAS SAFETY CORPORATION

CERTIgaz

GIORIK 95
INNOVATIVE COOKING EQUIPMENT SINCE 1963

unika900 FRIGGITRICI ELETTRICHE

ELECTRIC DEEP FAT FRYERS • ELEKTRO FRITEUSEN
FRITEUSES ÉLECTRIQUES • FREIDORAS ELÉCTRICAS

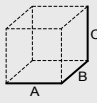
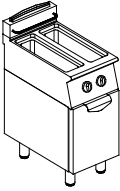
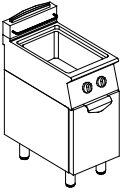
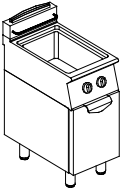
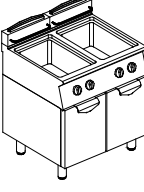
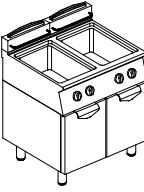
CODICE Code Kode Code Codigo		VOL./PESO Vol./Weight Vol./Gewicht Vol./Poids Vol./Pesos	VAC		CAPACITÀ Capacity Inhalt Capacité Capacidad	PREZZO Price Preis Prix Precio	
			230-1N 50/60 Hz	400-3N 50/60 Hz			m ³ /kg
	(A x B x C) mm				Lt.	€	
	⚡ FE9207	400x900x900	0,8/88		14	8 + 8	3.696,00
	⚡ FE9207M	400x900x900	0,8/88		14	8 + 8	4.341,00
	⚡ FE9113	400x900x900	0,8/78		12	13	2.537,00
	⚡ FE9117	400x900x900	0,8/78		16,5	17	2.794,00
	⚡ FE9121	400x900x900	0,8/78		19,5	21	2.986,00
	⚡ FE9113M	400x900x900	0,8/78		12	13	3.415,00
	⚡ FE9117M	400x900x900	0,8/78		16,5	17	3.715,00
	⚡ FE9121M	400x900x900	0,8/88		19,5	21	4.006,00
	⚡ FE9217	800x900x900	1,6/140		33	17 + 17	4.850,00
	⚡ FE9221	800x900x900	1,6/150		39	21 + 21	5.454,00
	⚡ FE9217M	800x900x900	1,6/140		33	17 + 17	5.474,00
	⚡ FE9221M	800x900x900	1,6/150		39	21 + 21	6.242,00



...M

ELECTRONIC
MELTING CONTROL

I prezzi sono **INCLUSIVI DEI CESTI** e di una vasca raccogli olio con filtro • Prices **INCLUDE BASKETS** and one oil draining tank with filter • Preise **ENTHALTEN KÖRBE** und eine Ölsammelwanne mit Filter • Les prix **COMPRENENT LES PANIERS** et un bac recueil huile • Los precios **INCLUYEN LOS CESTOS** y una cuba recoge aceite con filtro.

ACCESSORI PER FRIGGITRICI

unika900

ACCESSORIES FOR FRYERS • ZUBEHÖR FÜR FRITZEUSEN
ACCESSOIRES POUR FRITEUSES • ACCESORIOS PARA FREIDORAS

CODICE Code Kode Code Codigo	 (A x B x C) mm	PREZZO Price Preis Prix Precio €
--	---	---



FRIGGITRICI A GAS CON SCAMBIATORI DI CALORE INTERNI GAS FRYER WITH INTERNAL HEAT EXCHANGERS



FRIGGITRICI ELETTRICHE ELECTRIC FRYERS

FRIGGITRICI A GAS CON SCAMBIATORI DI CALORE ESTERNI GAS FRYER WITH EXTERNAL HEAT EXCHANGERS

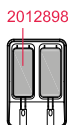
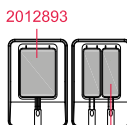
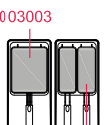
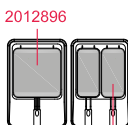

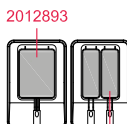
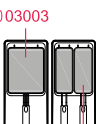
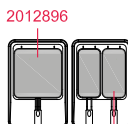
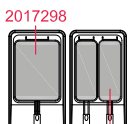
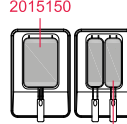
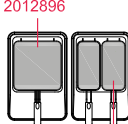
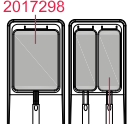
8 + 8 Lt	13 Lt 13 + 13 Lt	FG7215T - FG7215MT 13 + 13 Lt	15 Lt 15 + 15Lt	17 Lt 17 + 17 Lt	21 Lt 21 + 21 Lt
 2012898	 2012893 NO FG7215T \ FG7215MT	 2003003 FG7215T \ FG7215MT		 2012896	
 2012898	 2012893 2012892		 2003003 2003002	 2012896 2012895	 2017298 2017307
	 2015150			 2012896 2012895	 2017298 2017307

Cestelli per friggitorici • Baskets for fryers • Körbe für Friteusen • Paniers pour friteuses • Cestos para freidoras

2015154	mm 105x310x120	58,00
2015150	mm 215x310x120	70,00
2012895	mm 146x310x120	66,00
2012896	mm 300x310x120	77,00
2017307	mm 146x400x120	72,00
2017298	mm 300x400x120	100,00
2012892	mm 113x310x120	58,00
2012893	mm 230x310x120	70,00
2012898	mm 130x310x120	58,00



Vasche raccogli olio con filtro • Oil tanks with filter • Delsamhelwanne mit filter Bacs de récupération huile avec filtre • Cubas recoge aceite con filtro

2015470	Per friggitorici gas • For gas deep fat fryers • Für Gas Friteusen Pour friteuses gaz • Para freidoras a gas	151,00
2013248	Per friggitorici elettriche • For electric deep fat fryers • Für Elektro Friteusen • Pour friteuses électriques • Para freidoras eléctricas	151,00

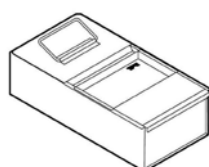

BRASIERE ROVESCIBILI





TILTING BRATT PANS • KIPPBRATPFANNEN

SAUTEUSES BASCULANTES • SARTENES BASCULANTES

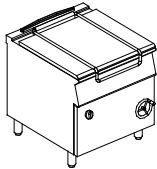
CODICE Code Kode Code Codigo		VOL./PESO Vol./Weight Vol./Gewicht Vol./Poids Vol./Pesos	GAS	VAC 230-1N 50/60 Hz	VAC 400-3N 50/60 Hz	PREZZO Price Preis Prix Precio
	(A x B x C) mm	m ³ /kg	kW	kW	kW	€





Brasiera sollevamento manuale • Manual tilting • Manuelles Heben • Levage manual
Levantiamento manual

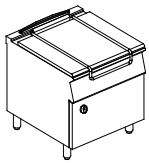

	BG94FM	800x900x900 80 Lt.	1,2/170	20		5.933,00
<small>Non disponibile per la Comunità Europea • Not available for UE market</small>						
	BG94XM	800x900x900 80 Lt.	1,2/170	20		7.251,00
	BE94FM	800x900x900 80 Lt.	1,2/170		15	6.151,00
<small>Non disponibile per la Comunità Europea • Not available for UE market</small>						
	BE94XM	800x900x900 80 Lt.	1,2/170		15	7.462,00





Brasiera sollevamento automatico • Automatic tilting • Automatisches Heben
Levage Automatic • Levantiamento automatico

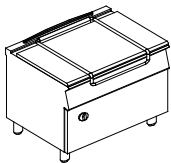

	BG94FA	800x900x900 80 Lt.	1,2/170	20	0,1	7.112,00
<small>Non disponibile per la Comunità Europea • Not available for UE market</small>						
	BG94XA	800x900x900 80 Lt.	1,2/170	20	0,1	8.231,00
	BE94FA	800x900x900 80 Lt.	1,2/170		15,1	7.307,00
<small>Non disponibile per la Comunità Europea • Not available for UE market</small>						
	BE94XA	800x900x900 80 Lt.	1,2/170		15,1	8.793,00

Brasiera sollevamento automatico • Automatic tilting • Automatisches Heben
Levage Automatic • Levantiamento automatico



	BG96FA	1200x900x900 120 Lt.	2,1/200	24	0,1	8.599,00
<small>Non disponibile per la Comunità Europea • Not available for UE market</small>						
	BG96XA	1200x900x900 120 Lt.	2,1/200	24	0,1	10.742,00
	BE96FA	1200x900x900 120 Lt.	2,1/200		19,1	8.857,00
<small>Non disponibile per la Comunità Europea • Not available for UE market</small>						
	BE96XA	1200x900x900 120 Lt.	2,1/200		19,1	10.954,00

F Vasca in ferro • Mild iron tank • Becken aus Eisen • Cuve en fer •
Cuba de hierro

Non disponibile per la comunità Europea • Not available for
UE market • Nicht erhältlich für die Europäische Gemeinschaft
• Non disponible pour la Communauté européenne • No
disponible para la Comunidad europea

X Vasca in acciaio inossidabile Duplex 2304 • Duplex 2304
stainless steel tank • Becken aus rostfreiem Stahl Duplex
2304 • Cuve en acier inoxydable Duplex 2304 • Cuba de
acero inoxidable Duplex 2304

PENTOLE



unika900

BOILING PANS • KOCHKESSEL • MARMITES • MARMITAS

CODICE Code Kode Code Codigo	 (A x B x C) mm	VOL./PESO Vol./Weight Vol./Gewicht Vol./Poids Vol./Pesos m³/kg	GAS kW	VAC 230-1N 50/60 Hz kW	VAC 400-3N 50/60 Hz kW	PREZZO Price Preis Prix Precio €
--	---	---	-----------	---------------------------------	---------------------------------	---

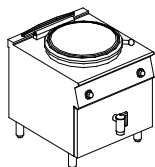

Pentole a gas diretto • Gas direct heating boiling pans • Gas-Kochkessel direkt beheizt
Marmites à gaz chauffage direct • Marmitas a gas con calentamiento directo



 PGD910	800x900x900 100 Lt.	1,2/140	21			6.050,00
 PGD915	800x900x900H 150 Lt.	1,2/150	24			6.460,00

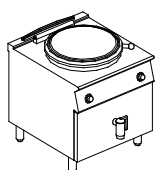

Pentole a gas indiretto • Gas indirect heating boiling pans • Gas-Kochkessel indirekt beheizt
Marmites gaz chauffage indirect • Marmitas a gas con calentamiento indirecto

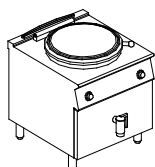

 PGI910	800x900x900 100 Lt.	1,2/180	21			8.396,00
 PGI915	800x900x900H 150 Lt.	1,2/200	24			8.571,00

Pentole indirette elettriche • Electric indirect heating boiling pans • Elektro-Kochkessel indirekt beheizt
Marmites électriques chauffage indirect • Marmitas eléctricas con calentamiento indirecto



 PEI910	800x900x900 100 Lt.	1,2/180		21		8.257,00
 PEI915	800x900x900H 150 Lt.	1,2/200		21		8.748,00

ACCESSORI PER PENTOLE

ACCESSORIES FOR BOILING PANS • KOCHKESSELZUBEHÖR • ACCESSOIRES POUR MARMITES
ACCESORIOS PARA MARMITAS



Coperchio autoclave • Pressure lid • Druckdeckel • Couvercle autoclave • Tapa autoclave

2022498						1.606,00
----------------	--	--	--	--	--	-----------------

Cestelli • Baskets • Körbe • Paniers • Cestos

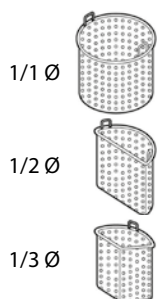

5920101	100 l.		1/1 Ø mm	560x370H		705,00
5920151	150 l.		1/1 Ø mm	560x440H		737,00
5920102	100 l.		1/2 Ø mm	560x370H		508,00
5920152	150 l.		1/2 Ø mm	560x440H		536,00
5920103	100 l.		1/3 Ø mm	560x370H		373,00
5920153	150 l.		1/3 Ø mm	560x440H		403,00

Griglietta di scarico • Plug hole filter • Ablaufgitter • Grille pour bonde • Rejilla de desagüe



2019860						39,00
----------------	--	--	--	--	--	--------------

NEUTRAL UNITS • ARBEITSELEMENTE
ÉLÉMENTS NEUTRES • MUEBLES NEUTROS

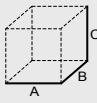
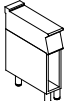
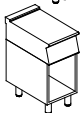
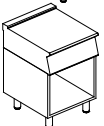
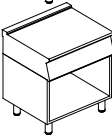
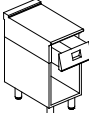
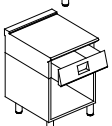
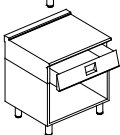
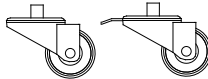
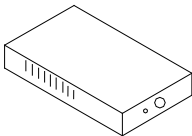
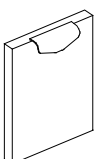
CODICE Code Kode Code Codigo	 (A x B x C) mm	VOL./PESO Vol./Weight Vol./Gewicht Vol./Poids Vol./Pesos m³/kg	VAC 230-1N 50/60 Hz kW	PREZZO Price Preis Prix Precio €
 EN910G	200x900x900	0,5/50		725,00
 EN920G	400x900x900	0,6/60		985,00
 EN930G	600x900x900	0,9/65		1.082,00
 EN940G	800x900x900	1,1/80		1.284,00
Con cassetto • With drawer • Mit Schublade • Avec tiroir • Con cajón				
 EN92CG	400x900x900	0,6/70		1.245,00
 EN93CG	600x900x900	0,6/75		1.491,00
 EN94CG	800x900x900	1,1/90		1.575,00
ACCESSORI				
ACCESSORIES • ZUBEHÖR • ACCESSOIRES • ACCESORIOS				
Kit ruote • Kit castor • Rädersatz • Kit roulettes • Kit ruedas				
 KIT348	4 ruote (2 autobloccanti) • 4 wheels (2 self-locking) • 4 Räder (2 selbstsichernd) • 4 roues (2 autobloquantes) • 4 ruedas (2 autobloqueantes)			195,00
Elemento riscaldante ventilato per armadi • Ventilated cupboard base warmer • Umluft-Heizblock für Schrank • Corps de chauffe ventilé pour armoire • Elemento calentador ventilado para armarios				
 6000020	310x250x90		2	518,00
Porte • Doors • Flügeltüren • Portes • Puertas				
 2016437				156,00

ACCESSORI

unika900

ACCESSORIES • ZUBEHÖR • ACCESSOIRES • ACCESORIOS

CODICE Code Kode Code Codigo	PREZZO Price Preis Prix Precio
--	--

€



Colonnina acqua • Water tap • Wasserhahn • Robinet de l'eau • Poste agua

7060077 510x725h

325,00

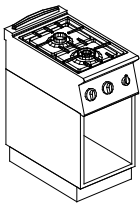

Zoccolatura • Plinth • Sockelblende • Socle • Zócalo

130,00 x ml

Kit supporto a ponte • Kit for bridge cooking suites • Satz für Brückenkochblöcke
Kit pour bloc de cuisson à pont • Kit soporte tipo puente

2020469 L = 400 mm

132,00

2020470 L = 600 mm

137,00

2020471 L = 800 mm

145,00

2020472 L = 1000 mm

150,00

2020473 L = 1200 mm

156,00

2020474 L = 1400 mm

168,00

2020475 L = 1600 mm

198,00

2020476 L = 1800 mm

243,00

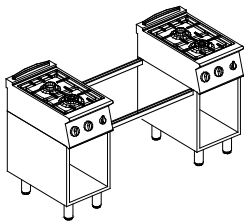

Corrimano • Trayslide • Tabletrutsche • Rampe à plateaux • Barra

168,00 x ml

2020477 L = 400 mm

68,00

2020478 L = 800 mm

135,00

2020479 L = 1200 mm

203,00

2020480 L = 1600 mm

270,00

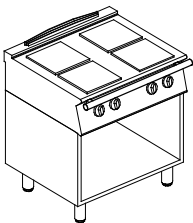

Corrimano portapiatti • Trayslide • Tabletrutsche • Rampe à plateaux • Barra para platos

194,00 x ml

2020481 L = 400 mm

78,00

2020482 L = 800 mm

156,00

2020483 L = 1200 mm

233,00

2020484 L = 1600 mm

312,00

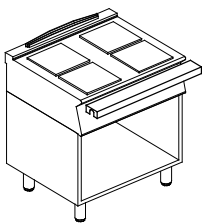

Struttura porta teglie • Tray holder structure • Backblechablage • Structure porte-plaque • Estructura para bandejas

2022727 L = 800 mm

2022728 L = 1200 mm

2022729 L = 1600 mm

2022730 L = 2000 mm

2022731 L = 2400 mm

2022732 L = 2800 mm

Su richiesta
On request
Auf Anfrage
Sur demande
Previa solicitud

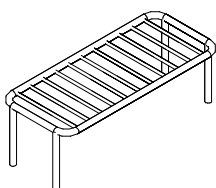

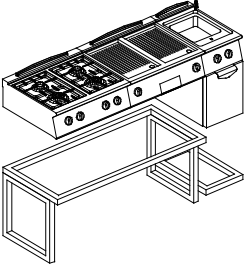
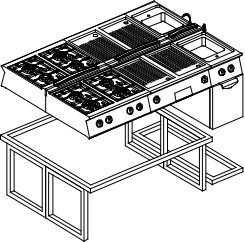
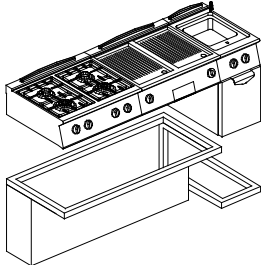
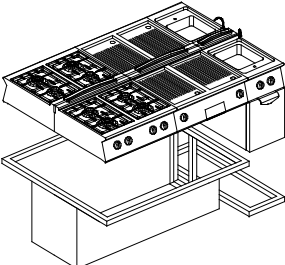
CODICE		PREZZO
Code		Price
Kode		Preis
Code		Prix
Codigo		Precio
		€
	<p>STL9</p> <p>Struttura portante a telaio - 1 lato • Support frame - 1 sided Untergestell - einseitig • Structure portante avec bâti - 1 côté Estructura portante tipo bastidor - 1 lado</p>	1.625,00 x ml
	<p>STLD9</p> <p>Struttura portante a telaio - 2 lati • Support frame - 2 sided Untergestell - zweiseitig • Structure portante avec bâti - 2 côtés Estructura portante tipo bastidor - 2 lados</p>	2.278,00 x ml
	<p>STL9P</p> <p>Struttura portante a telaio con pannelli di tamponatura - 1 lato Support frame with kick panels - 1 sided • Untergestell mit Abschlusspaneelen - einseitig • Structure portante avec bâti et panneaux de parement - 1 côté • Estructura portante tipo bastidor con paneles de cierre - 1 lado</p>	2.148,00 x ml
	<p>STLD9P</p> <p>Struttura portante a telaio con pannelli di tamponatura - 2 lati Support frame with kick panels - 2 sided • Untergestell mit Abschlusspaneelen - zweiseitig • Structure portante avec bâti et panneaux de parement - 2 côtés • Estructura portante tipo bastidor con paneles de cierre - 2 lados</p>	3.059,00 x ml

unika900 TOP

unika900

GIORIK
INNOVATIVE COOKING EQUIPMENT SINCE 1963

LineaBase TOP 900 CUCINE A GAS

GAS RANGES • GASHERDE • FORNEAUX GAZ • COCINAS A GAS

CODICE Code Kode Code Codigo	 (A x B x C) mm	VOL./PESO Vol./Weight Vol./Gewicht Vol./Poids Vol./Pesos m ³ /kg	GAS kW	VAC 230-1N 50/60 Hz kW	VAC 400-3N 50/60 Hz kW	PREZZO Price Preis Prix Precio €
--	---	--	-----------	---------------------------------	---------------------------------	---

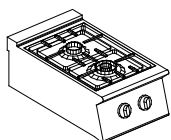

ECG920T

400x900x307

0,3/40

9,5

1.311,00

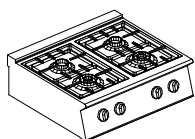

ECG940T

800x900x307

0,45/80

19

2.068,00

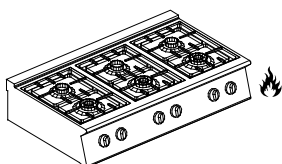

ECG960T

1200x900x307

0,8/1000

28,5

2.960,00

unika900 TOP CUCINE A GAS

GAS RANGES • GASHERDE • FORNEAUX GAZ • COCINAS A GAS

Griglie standard
Standard grids
Standardgitter
Grilles standard
Parrillas estándar

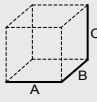
CODICE Code Kode Code Codigo	 (A x B x C) mm	VOL./PESO Vol./Weight Vol./Gewicht Vol./Poids Vol./Pesos m ³ /kg	GAS kW	VAC 230-1N 50/60 Hz kW	VAC 400-3N 50/60 Hz kW	PREZZO Price Preis Prix Precio €
--	---	--	-----------	---------------------------------	---------------------------------	---

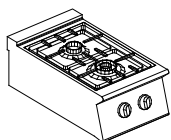

CG920T

400x900x307

0,3/40

16

1.662,00

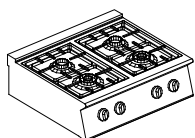

CG940T

800x900x307

0,45/80

32

2.679,00

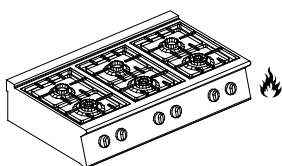

CG960T

1200x900x307

0,8/100

48

3.705,00

CUCINE A GAS





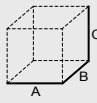

unika900
TOP

GAS RANGES • GASHERDE • FORNEAUX GAZ • COCINAS A GAS

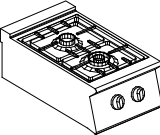
CODICE		VOL./PESO	GAS	VAC	VAC	PREZZO
Code Kode Code Codigo		Vol./Weight Vol./Gewicht Vol./Poids Vol./Pesos		230-1N 50/60 Hz	400-3N 50/60 Hz	Price Preis Prix Precio
	(A x B x C) mm	m ³ /kg	kW	kW	kW	€

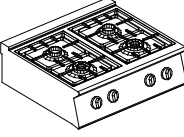

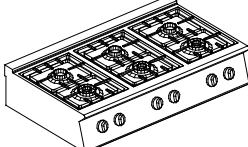
Griglie a filo piano
Grids flush with top
Flächenbündige Gitter
Grilles à fleur du plan
Parrillas a ras de cocina

		CG92FT	400x900x307	0,3/40	16	2.060,00
		CG94FT	800x900x307	0,45/80	32	3.331,00
		CG96FT	1200x900x307	0,8/100	48	4.810,00

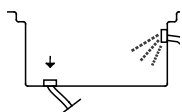

Sistema carico acqua con scarico troppo pieno. Modifica da richiedere al momento dell'ordine • Water filling system with overflow pipe. Any change should be requested upon order • Wasserzulaufsystem mit Überlaufschutz. Jede Änderung muss bei der Bestellung angefordert werden • Système de remplissage eau avec trop plein d'évacuation. Modification à demander au moment de la commande • Sistema de entrada de agua con desagüe de desbordamiento. Solicitar modificación al efectuar el pedido

2020048	Per 2 fuochi • For 2 burners • Für 2 Brenner • Pour 2 feux • Para 2 quemadores	405,00
2020049	Per 4 fuochi • For 4 burners • Für 4 Brenner • Pour 4 feux • Para 4 quemadores	509,00
2020050	Per 6 fuochi • For 6 burners • Für 6 Brenner • Pour 6 feux • Para 6 quemadores	747,00

Sistema carico acqua disponibile solo per griglie a filo piano • Water filling system available only for grids flush with top • Wasserzulaufsystem verfügbar nur für Flächenbündige Gitter • Système de remplissage disponible seulement pour grilles à fleur du plan • Sistema de entrada de agua disponible solamente para parrillas a ras de cocina

CONFIGURAZIONE BRUCIATORI

CONFIGURATION BURNERS • KONFIGURATION BRENNER
CONFIGURATION BRÛLEURS • CONFIGURACION DE QUEMADORES

STANDARD

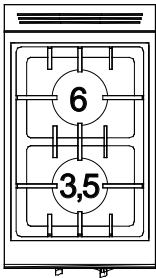

9,5 kW

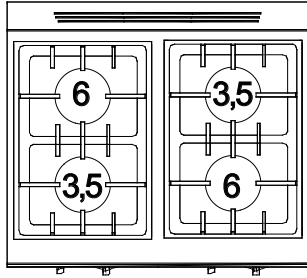

19 kW

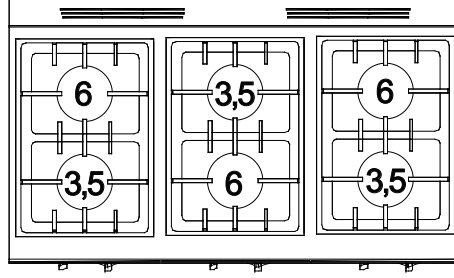

28,5 kW

CONFIGURAZIONE BRUCIATORI

CONFIGURATION BURNERS • KONFIGURATION BRENNER
CONFIGURATION BRÛLEURS • CONFIGURACION DE QUEMADORES

STANDARD

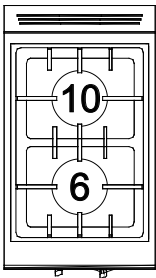

16 kW

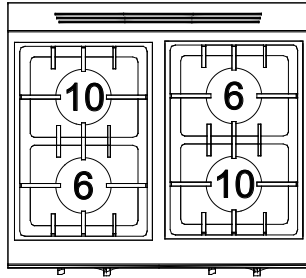

32 kW

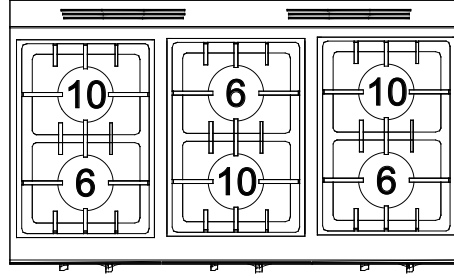

4,008 kW

Extra prezzo per configurazioni speciali
Extra price for special configurations • Extra Preis für Sonderkonfigurationen
Extra prix pour configurations spéciales • Extra precio para configuraciones especiales

20 kW

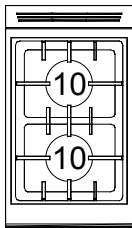

+116,00 €

36 kW

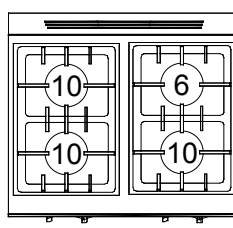

+116,00 €

40 kW

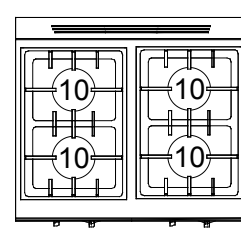

+233,00 €

52 kW

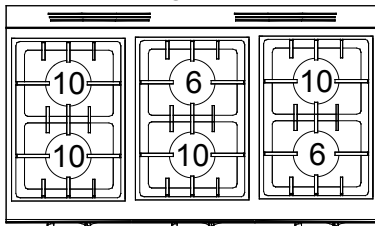

+116,00 €

60 kW

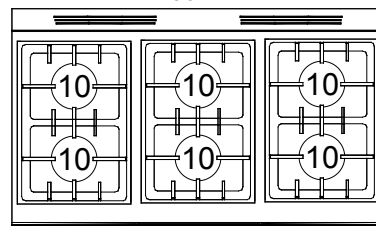

+349,00 €

CUCINE TUTTAPIASTRA

unika900
TOP

SOLID TOPS • GLÜHPLATTENHERDE
CUCINIÈRES COUP DE FEU • PLACAS RADIANTES

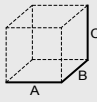
CODICE Code Kode Code Codigo		VOL./PESO Vol./Weight Vol./Gewicht Vol./Poids Vol./Pesos	GAS	VAC		PREZZO Price Preis Prix Precio
				230-1N 50/60 Hz	400-3N 50/60 Hz	
	(A x B x C) mm	m ³ /kg	kW	kW	kW	€

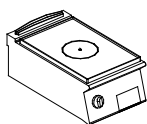

TG920T

400x900x307

0,3/60

7,5

2.332,00

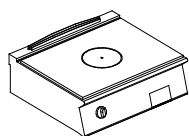

TG940T

800x900x307

0,45/90

15

2.828,00

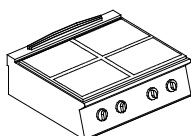

TE940T

800x900x307

0,45/105

12

5.343,00

ACCESSORI

ACCESSORIES • ZUBEHÖR • ACCESSOIRES • ACCESORIOS

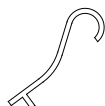

Leverino • Lever • Eisen • Petit levier • Palanca

2019661

66,00

unika900

CUCINE ELETTRICHE

ELECTRIC RANGE • ELEKTROHERDE
FORNEAUX ÉLECTRIQUES • COCINAS ELÉCTRICAS

CODICE Code Kode Code Codigo		VOL./PESO Vol./Weight Vol./Gewicht Vol./Poids Vol./Pesos	GAS	VAC 230-1N 50/60 Hz	VAC 400-3N 50/60 Hz	PREZZO Price Preis Prix Precio
	(A x B x C) mm	m ³ /kg	kW	kW	kW	€

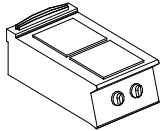

CE92QT

400x900x307
2x(300x300)

0,6/45

8

2.211,00

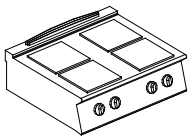

CE94QT

800x900x307
4x(300x300)

1,1/75

16

3.862,00

CUCINE ELETTRICHE VETROCERAMICA

ELECTRIC RANGES CERAMIC GLASS • ELEKTROHERDE GLASKERAMIK
PLAQUES DE CUISSON EN VITROCÉRAMIQUE • COCINAS ELECTRICAS VETROCERAMICA

CODICE Code Kode Code Codigo		VOL./PESO Vol./Weight Vol./Gewicht Vol./Poids Vol./Pesos	GAS	VAC 230-1N 50/60 Hz	VAC 400-3N 50/60 Hz	PREZZO Price Preis Prix Precio
	(A x B x C) mm	m ³ /kg	kW	kW	kW	€

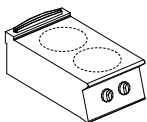

CV920T

400x900x307
2x ø270

0,3/45

5,5

2.563,00

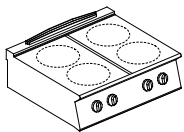

CV940T

800x900x307
4x ø270

0,45/75

11

4.129,00

CUCINE A INDUZIONE

unika900
TOP

INDUCTION RANGES • INDUKTIONSHERDE • PLAQUES DE CUISSON À INDUCTION
COCINAS ELECTRICAS A INDUCCIÓN

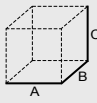
CODICE Code Kode Code Codigo		VOL./PESO Vol./Weight Vol./Gewicht Vol./Poids Vol./Pesos	GAS	VAC 230-1N 50/60 Hz	VAC 400-3N 50/60 Hz	PREZZO Price Preis Prix Precio
	(A x B x C) mm	m ³ /kg	kW	kW	kW	€

Piastre induzione • Induction rings • Induktionsplatten • Foyers à induction • Placas de induccion

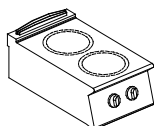

	CI920T	400x900x307 2x ø270	0,3/45		10	9.247,00
---	---------------	------------------------	--------	--	----	-----------------

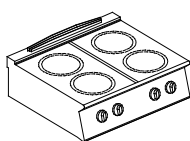

	CI940T	800x900x307 4x ø270	0,45/75		20	16.418,00
---	---------------	------------------------	---------	--	----	------------------

Wok induzione • Induction wok • Induktion-Wok • Wok à induction • Placas de induccion Wok

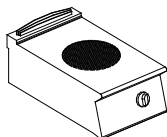

	CW920T	400x900x307 1x ø300	0,3/45		5	7.188,00
---	---------------	------------------------	--------	--	---	-----------------

Piastre induzione tutto piano • Even heating induction plates • Durchgehende
Induktionskochfläche • Plans à induction sur tout le plan • Cocinas de inducción entera

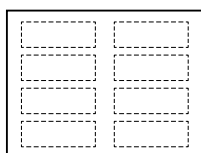

CI92TT	400x900x307	0,6/75		14	12.410,00
---------------	-------------	--------	--	----	------------------

CI94TT	800x900x307	1,1/115		28	21.711,00
---------------	-------------	---------	--	----	------------------

ACCESSORI

ACCESSORIES • ZUBEHÖR • ACCESSOIRES • ACCESORIOS









Pentola per wok • Pan for wok • Topf für Wok • Casserolle pour wok • Olla para wok

5920010	Dim. ø360x102H mm	403,00
----------------	-------------------	---------------

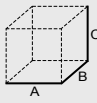
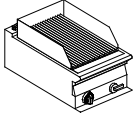
unika900

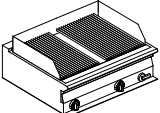

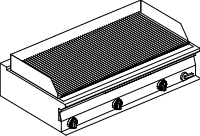

AQUA-GRILL A GAS

GAS STEAMGRILL • DAMPF GRILL, GASAUFSÜHRUNG • GRILLE VAPEUR À GAZ
 VAPOR BARBACOA DE GAS

CODICE Code Kode Code Codigo		VOL./PESO Vol./Weight Vol./Gewicht Vol./Poids Vol./Pesos	GAS	VAC		PREZZO Price Preis Prix Precio
				230-1N 50/60 Hz	400-3N 50/60 Hz	
	(A x B x C) mm	m ³ /kg	kW	kW	kW	€
  GL92TV	400x900x307	0,3/45	11			2.754,00
  GL94TV	800x900x307	0,45/75	22			4.143,00
  GL96TV	1200x900x307	0,8/100	33			5.484,00

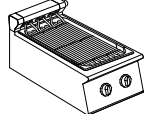
AQUA-GRILL ELETTRICI

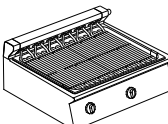
ELECTRIC STEAMGRILL • DAMPF GRILL, ELEKTROAUFSÜHRUNG • GRILLE VAPEUR ÉLECTRIQUE
 VAPOR BARBACOA ELÉCTRICO



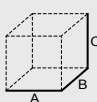

  GL92TE	400x900x307	0,3/40			5,4	3.098,00
  GL94TE	800x900x307	0,45/70			10,8	4.605,00

GRIGLIE A PIETRA LAVICA

LAVA ROCK GRILLS • LAVASTEINGRILLS
 GRILLES À PIERRE VOLCANIQUE • BARBACOA DE PIEDRA LÁVICA

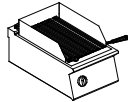
CODICE Code Kode Code Codigo		VOL./PESO Vol./Weight Vol./Gewicht Vol./Poids Vol./Pesos	GAS	VAC		PREZZO Price Preis Prix Precio
				230-1N 50/60 Hz	400-3N 50/60 Hz	
	(A x B x C) mm	m ³ /kg	kW	kW	kW	€

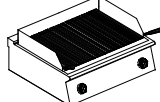
Griglia per carne • Grill for meat • Fleischrost • Grille pour viande • Rejilla para carne

  GL92TGC	400x900x307	0,3/50	15			2.420,00
  GL94TGC	800x900x307	0,45/60	30			3.635,00

FRY TOP A GAS

unika900
TOP

GAS GRIDDLE PLATES • GAS-GRILLPLATTEN
GRILLADES GAZ • FRY-TOP A GAS

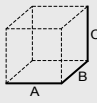
CODICE Code Kode Code Codigo	 (A x B x C) mm	VOL./PESO Vol./Weight Vol./Gewicht Vol./Poids Vol./Pesos m ³ /kg	GAS kW	VAC 230-1N 50/60 Hz kW	VAC 400-3N 50/60 Hz kW	PREZZO Price Preis Prix Precio €
--	---	--	-----------	---------------------------------	---------------------------------	---

Liscio • Smooth • Glatt • Lisse • Liso

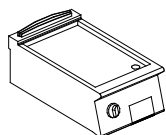

 FLG92TF	400x900x307	0,3/70	9			1.945,00
Non disponibile per la Comunità Europea • Not available for UE market						

 FLG92CRX	400x900x307	0,3/70	9			2.367,00
Termostato • Thermostated • Thermostate • Thermostatisiert • Termostatizado						

Rigato • Ribbed • Gerillt • Nervuré • Acanalado

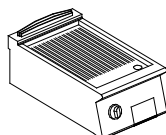

 FRG92TF	400x900x307	0,3/70	9			2.097,00
Non disponibile per la Comunità Europea • Not available for UE market						

 FRG92CRX	400x900x307	0,3/70	9			2.597,00
Termostato • Thermostated • Thermostate • Thermostatisiert • Termostatizado						

Liscio • Smooth • Glatt • Lisse • Liso

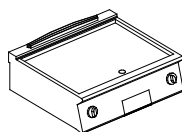



 FLG941TF	800x900x307	0,45/140	18			2.969,00
Non disponibile per la Comunità Europea • Not available for UE market						

 FLG941CRX	800x900x307	0,45/140	18			3.518,00
Termostato • Thermostated • Thermostate • Thermostatisiert • Termostatizado						

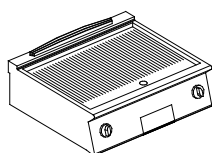
Rigato • Ribbed • Gerillt • Nervuré • Acanalado





 FRG941TF	800x900x307	0,45/140	18			3.380,00
Non disponibile per la Comunità Europea • Not available for UE market						

 FRG941CRX	800x900x307	0,45/140	18			4.127,00
Termostato • Thermostated • Thermostate • Thermostatisiert • Termostatizado						

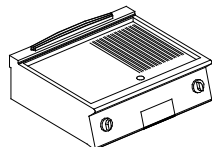
Liscio-Rigato • Smooth-Ribbed • Glatt-Gerillt • Lisse-Nervuré • Liso-Acanalado



 FMG941TF	800x900x307	0,45/140	18			3.224,00
Non disponibile per la Comunità Europea • Not available for UE market						

 FMG941CRX	800x900x307	0,45/140	18			3.858,00
Termostato • Thermostated • Thermostate • Thermostatisiert • Termostatizado						

F Piastra in ferro • Mild iron plate • Platte aus Eisen • Plaque en fer • Placa de hierro
Non disponibile per la comunità Europea • Not available for UE market • Nicht erhältlich für die Europäische Gemeinschaft • Non disponible pour la Communauté européenne • No disponible para la Comunidad europea

CRX Piastra in acciaio spessore 15 mm con finitura cromata satinata
Conforme al regolamento CE 1935/2004 riguardante materiali e oggetti a contatto con gli alimenti. Il materiale è antiaderente e garantisce resistenza alla corrosione e ai graffi. • Steel Chrome-plated satin finish, 15 mm thickness. In compliance with UE Regulation 1935/2004 on materials and articles in contact with food. The material is non-stick and guarantees resistance to corrosion and scratches. • Stahl Verchromt satiniert, 15 mm dick. • Acier chromé satiné, épaisseur 15 mm. • Acero Cromado satinado, 15 mm de espesor.



FRY TOP ELETTRICI

ELECTRIC GRIDDLE PLATES • ELEKTRO-GRILLPLATTEN
GRILLADES ÉLECTRIQUES • FRY-TOP ELÉCTRICOS

CODICE Code Kode Code Codigo	 (A x B x C) mm	VOL./PESO Vol./Weight Vol./Gewicht Vol./Poids Vol./Pesos m ³ /kg	GAS kW	VAC 230-1N 50/60 Hz kW	VAC 400-3N 50/60 Hz kW	PREZZO Price Preis Prix Precio €
--	---	--	-----------	---------------------------------	---------------------------------	---

Liscio • Smooth • Glatt • Lisse • Liso

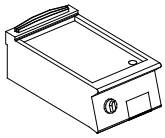

FLE92TF	400x900x307	0,3/70			8	2.147,00
<i>Non disponibile per la Comunità Europea • Not available for UE market</i>						

FLE92TCRX	400x900x307	0,3/70			8	2.417,00
------------------	-------------	--------	--	--	---	-----------------

Rigato • Ribbed • Gerillt • Nervuré • Acanalado

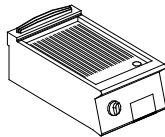

FRE92TF	400x900x307	0,3/70			8	2.272,00
<i>Non disponibile per la Comunità Europea • Not available for UE market</i>						

FRE92TCRX	400x900x307	0,3/70			8	2.632,00
------------------	-------------	--------	--	--	---	-----------------

Liscio • Smooth • Glatt • Lisse • Liso

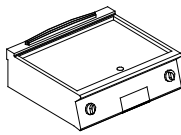

FLE941TF	800x900x307	0,45/140			16	3.277,00
<i>Non disponibile per la Comunità Europea • Not available for UE market</i>						

FLE941TCRX	800x900x307	0,45/140			16	3.767,00
-------------------	-------------	----------	--	--	----	-----------------

Rigato • Ribbed • Gerillt • Nervuré • Acanalado

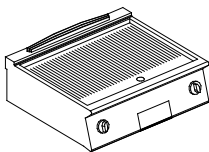

FRE941TF	800x900x307	0,45/140			16	3.652,00
<i>Non disponibile per la Comunità Europea • Not available for UE market</i>						

FRE941TCRX	800x900x307	0,45/140			16	4.131,00
-------------------	-------------	----------	--	--	----	-----------------

Liscio-Rigato • Smooth-Ribbed • Glatt-Gerillt • Lisse-Nervuré • Liso-Acanalado

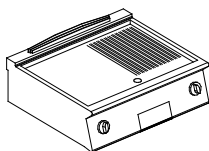

FME941TF	800x900x307	0,45/140			16	3.499,00
<i>Non disponibile per la Comunità Europea • Not available for UE market</i>						

FME941TCRX	800x900x307	0,45/140			16	3.939,00
-------------------	-------------	----------	--	--	----	-----------------

F Piastra in ferro • Mild iron plate • Platte aus Eisen • Plaque en fer • Placa de hierro
Non disponibile per la comunità Europea • Not available for UE market
• Nicht erhältlich für die Europäische Gemeinschaft • Non disponible pour la Communauté européenne • No disponible para la Comunidad europea

CRX Piastra in acciaio spessore 15 mm con finitura cromata satinata
Conforme al regolamento CE 1935/2004 riguardante materiali e oggetti a contatto con gli alimenti. Il materiale è antiaderente e garantisce resistenza alla corrosione e ai graffi. • Steel Chrome-plated satin finish, 15 mm thickness. In compliance with UE Regulation 1935/2004 on materials and articles in contact with food. The material is non-stick and guarantees resistance to corrosion and scratches. • Stahl Verchromt satiniert, 15 mm dick. • Acier chromé satiné, épaisseur 15 mm. • Acero Cromado satinado, 15 mm de espesor.

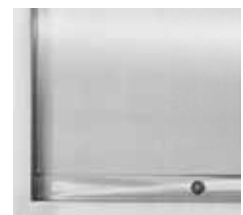



BAGNO MARIA

unika900
TOP

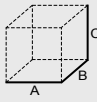
BAIN MARIES • BAIN-MARIES • BAIN-MARIE • BAÑO MARÍA

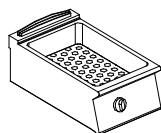
CODICE Code Kode Code Codigo	 (A x B x C) mm	VOL./PESO Vol./Weight Vol./Gewicht Vol./Poids Vol./Pesos m³/kg	GAS kW	VAC 230-1N 50/60 Hz kW	VAC 400-3N 50/60 Hz kW	PREZZO Price Preis Prix Precio €
--	---	---	-----------	---------------------------------	---------------------------------	---



 BM920T GN 1/1 + 1/3	400x900x307	0,3/40		1,65		1.727,00
---	-------------	--------	--	------	--	-----------------

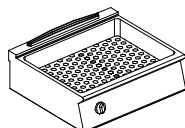

 BM940T GN 2/1 + 2GN 1/3	800x900x307	0,45/55		3,3		2.576,00
---	-------------	---------	--	-----	--	-----------------

I prezzi dei bagnomaria **NON COMPREDONO I CESTELLI** • The **BASKETS ARE NOT INCLUDED** in the price of bain maries • Die Preise der Bain Maries **ENTHALTEN KEINE KÖRBE** • Les prix des bain marie **NE COMPRENENT PAS LES PANIERS** • Los precios de los baño maría **NO INCLUYEN LOS CESTOS**.

ACCESSORI

ACCESSORI • ACCESSORIES • ZUBEHÖR • ACCESSOIRES

Bacinelle • Basins • Behälter • Bacs • Recipientes

2103135	GN 1/4 H150	55,00
2103080	GN 1/2 H150	72,00
2103107	GN 2/3 H150	89,00
2103134	GN 1/1 H150	108,00
2103144	GN 2/1 H150	184,00



Coperchi • Lids • Deckel • Couvercles • Tapas

2103202	Per • For • Für • Pour • Para: GN 1/4	23,00
2103077	Per • For • Für • Pour • Para: GN 1/2	21,00
2103201	Per • For • Für • Pour • Para: GN 2/3	39,00
2103106	Per • For • Für • Pour • Para: GN 1/1	62,00
2103145	Per • For • Für • Pour • Para: GN 2/1*	55,00



Traversino per bagno maria • Support for bain marie • Querstrebe für Bain-Marie • Traverse pour bain-marie
Larguero para baño maría

2014924	327x25	10,00
2014925	708x25	11,00



unika900

ELEMENTI NEUTRI

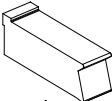
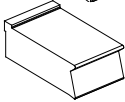
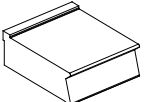
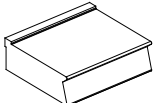
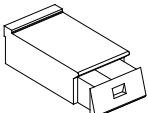
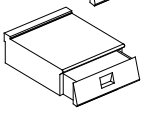
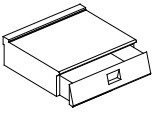
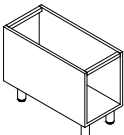
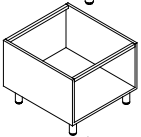
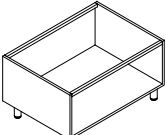
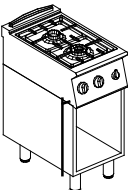
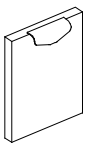

NEUTRAL UNITS • ARBEITSELEMENTE
ÉLÉMENTS NEUTRES • MUEBLES NEUTROS

CODICE Code Kode Code Codigo	 (A x B x C) mm	VOL./PESO Vol./Weight Vol./Gewicht Vol./Poids Vol./Pesos m ³ /kg	PREZZO
			Price Preis Prix Precio €
 EN910T	200x900x307	0,15/32	536,00
 EN920T	400x900x307	0,2/35	710,00
 EN930T	600x900x307	0,3/40	797,00
 EN940T	800x900x307	0,35/45	985,00
Con cassetto • With drawer • Mit Schublade • Avec tiroir • Con cajón			
 EN92CT	400x900x307	0,2/40	971,00
 EN93CT	600x900x307	0,2/45	1.223,00
 EN94CT	800x900x307	0,35/50	1.284,00
Base neutra • Base unit • Basiseinheit • Base neutre • Base neutra			
 BV920G	400x835x650	0,46/25	502,00
 BV940G	800x835x650	0,9/30	595,00
 BV960G	1200x835x650	0,9/35	690,00
ACCESSORI PER ELEMENTI NEUTRI			
ACCESSORIES FOR NEUTRAL UNITS • ZUBEHÖR FÜR ARBEITSELEMENTE ACCESSOIRES POUR ÉLÉMENTS NEUTRES • ACCESORIOS PARA MUEBLES NEUTROS			
Rampa gas • Gas burner ramp • Gasrampe • Rampe gaz • Rampa gas			
 2026093			79,00
Porte • Doors • Flügeltüren • Portes • Puertas			
 2016437			156,00

ACCESSORI PER CUCINE

unika900
TOP

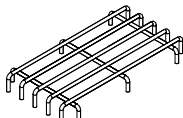
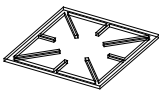
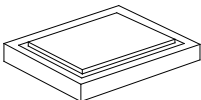
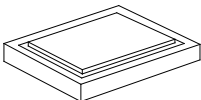
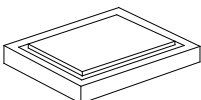
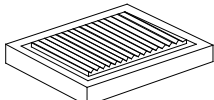
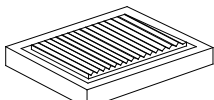

ACCESSORIES FOR RANGES • ZUBEHÖR FÜR HERDE
ACCESSOIRES POUR FORNEAUX • ACCESORIOS PARA COCINA

CODICE		PREZZO
Code		Price
Kode		Preis
Code		Prix
Codigo		Precio
		€
	2016194 394x371	<p>Griglia in ghisa vetrificata monofuoco • Single-burner vitrified cast iron pan rest • Einflammen-Topfträger aus verglastem Gusseisen • Grille en fonte vitrifiée monofeu • Rejilla de hierro fundido vitrificada para quemador único</p> <p>Non ordinabile per Linea Base • Not available for Linea Base • Nicht verfügar für Linea Base • Non disponibile pour Linea Base • No disponible para Linea Base</p> <p>145,00</p>
	2022577 360x360	<p>Griglia in ghisa monofuoco per Linea Base • Single-burner cast iron pan rest for Base Line • Einflammen-Topfträger für Basis-Linie • Grille en fonte monofeu pour la Ligne Base • Rejilla de hierro fundido con quemador único para la Línea Base</p> <p>72,00</p>
	2019841	<p>Griglia in tondino • Rounded metal grill • Rundeisengitter • Grille en fil rond • Parrilla de varillas</p> <p>Non ordinabile per Linea Base • Not available for Linea Base • Nicht verfügar für Linea Base • Non disponibile pour Linea Base • No disponible para Linea Base</p> <p>273,00</p>
	2020491 INOX	<p>Griglie a filo piano (non ordinabile per linea base) • Grids flush with top • Flächenbündige Gitter • Grilles à fleur du plan • Parrillas a ras de cocina</p> <p>689,00</p>
	2019054 GHISA • Cast iron • Gusseisen • Fonte • Hierro fundido	68,00
	2020748 390x360	<p>Piastra liscia in Fe510 • Smooth Fe510 plate • Fe510 Platte glatt Plaque lisse en Fe510 • Planchar de Fe510</p> <p>Non disponibile per la Comunità Europea • Not available for UE market</p> <p>189,00</p>
	2020748X 390x280	<p>Piastra rigata in acciaio inossidabile Duplex 2304 •</p> <p>282,00</p>
	2020749 390x360	<p>Piastra rigata in Fe510 • Ribbed Fe510 plate • Fe510 Gusseisenplatte gerillt • Plaque rajée en Fe510 • Planchar panuradas de Fe510</p> <p>Non disponibile per la Comunità Europea • Not available for UE market</p> <p>202,00</p>
	2020749X 390x280	<p>Piastra rigata in acciaio inossidabile Duplex 2304 •</p> <p>296,00</p>

unika900

ACCESSORI PER FRY TOP

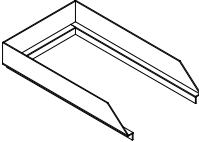
ACCESSORIES FOR FRY TOP • ZUBEHÖR FÜR GAS-GRILLPLATTEN
ACCESSOIRES POUR GRILLADES GAZ • ACCESORIOS PARA FRY-TOP A GAS

CODICE Code Kode Code Codigo		PREZZO Price Preis Prix Precio
		€
Paraspruzzi • Splashguard • Spritzenschutz • Anti-éclaboussures • Antisalpaduras		
	2026876 Per piastra unica 1/2 • For single plate 1/2 • Für Großfeldkochplatte 1/2 • Pour plaque unique 1/2 • Para placa única 1/2	197,00
	2026077 Per piastra unica 1/1 • For single plate 1/1 • Für Großfeldkochplatte 1/1 • Pour plaque unique 1/1 • Para placa única 1/1	220,00
Raschietti per fry top • Scrapers for fry top • Kratzer für Grillplatten Grattoir four grills • Raspador para fry top		
	7080100 Per piastra liscia • For smooth plate • Für glatte Platte Pour plaque lisse • Para plancha lisa	58,00
	7080101 Per piastra rigata • For ribbed plate • Für gerillte Platte Pour plaque nervurée • Para plancha acanalada	79,00

ACCESSORI

ACCESSORIES • ZUBEHÖR • ACCESSOIRES • ACCESORIOS

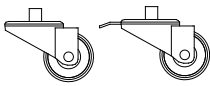

Kit ruote • Kit castor • Rädersatz • Kit roulettes • Kit ruedas		
KITT348	4 ruote (2 autobloccanti) • 4 wheels (2 self-locking) • 4 Räder (2 selbstsichernd) 4 roues (2 autobloquantes) • 4 ruedas (2 autobloqueantes)	195,00

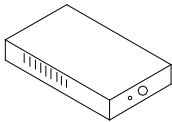

Elemento riscaldante ventilato per armadi • Ventilated cupboard base warmer • Umluft-Heizblock für Schrank • Corps de chauffe ventilé pour armoire • Elemento calentador ventilado para armarios		
6000020	310x250x90 • 2 kW 230-1N	518,00

ACCESSORI

ACCESSORIES • ZUBEHÖR • ACCESSOIRES • ACCESORIOS

unika900
TOP

CODICE	PREZZO
Code	Price
Kode	Preis
Code	Prix
Codigo	Precio
	€



Colonnina acqua • Water tap • Wasserhahn • Robinet de l'eau • Poste agua

7060077 510x725h

325,00

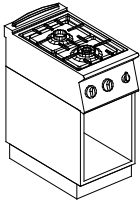

Zoccolatura • Plinth • Sockelblende • Socle • Zócalo

130,00 x ml

Kit supporto a ponte • Kit for bridge cooking suites • Satz für Brückenkochblöcke
Kit pour bloc de cuisson à pont • Kit soporte tipo puente

2020469 L = 400 mm

132,00

2020470 L = 600 mm

137,00

2020471 L = 800 mm

145,00

2020472 L = 1000 mm

150,00

2020473 L = 1200 mm

156,00

2020474 L = 1400 mm

168,00

2020475 L = 1600 mm

198,00

2020476 L = 1800 mm

243,00

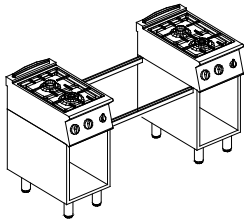

Corrimano • Trayslide • Tabletrutsche • Rampe à plateaux • Barra

168,00 x ml

2020477 L = 400 mm

68,00

2020478 L = 800 mm

135,00

2020479 L = 1200 mm

203,00

2020480 L = 1600 mm

270,00

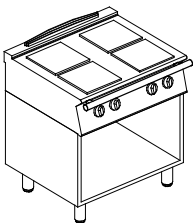

Corrimano portapiatti • Trayslide • Tabletrutsche • Rampe à plateaux • Barra para platos

194,00 x ml

2020481 L = 400 mm

78,00

2020482 L = 800 mm

156,00

2020483 L = 1200 mm

233,00

2020484 L = 1600 mm

312,00

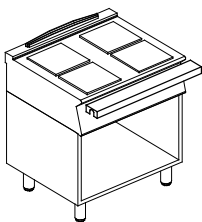

Struttura porta teglie • Tray holder structure • Backblechablage • Structure porte-plaque • Estructura para bandejas

2022727 L = 800 mm

2022728 L = 1200 mm

2022729 L = 1600 mm

2022730 L = 2000 mm

2022731 L = 2400 mm

2022732 L = 2800 mm

Su richiesta
On request
Auf Anfrage
Sur demande
Previa solicitud

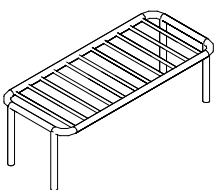

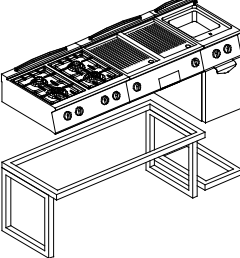
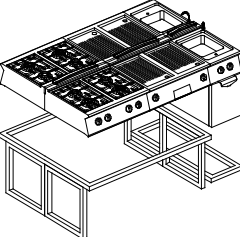
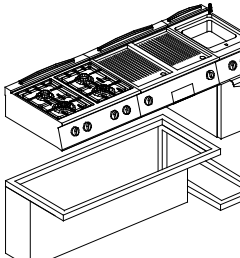
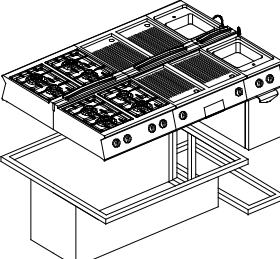
CODICE		PREZZO
Code		Price
Kode		Preis
Code		Prix
Codigo		Precio
		€
	<p>STL9</p> <p>Struttura portante a telaio - 1 lato • Support frame - 1 sided Untergestell - einseitig • Structure portante avec bâti - 1 côté Estructura portante tipo bastidor - 1 lado</p>	<p>1.625,00 x ml</p>
	<p>STLD9</p> <p>Struttura portante a telaio - 2 lati • Support frame - 2 sided Untergestell - zweiseitig • Structure portante avec bâti - 2 côtés Estructura portante tipo bastidor - 2 lados</p>	<p>2.278,00 x ml</p>
	<p>STL9P</p> <p>Struttura portante a telaio con pannelli di tamponatura - 1 lato Support frame with kick panels - 1 sided • Untergestell mit Abschlusspaneelen - einseitig • Structure portante avec bâti et panneaux de parement - 1 côté Estructura portante tipo bastidor con paneles de cierre - 1 lado</p>	<p>2.148,00 x ml</p>
	<p>STLD9P</p> <p>Struttura portante a telaio con pannelli di tamponatura - 2 lati Support frame with kick panels - 2 sided • Untergestell mit Abschlusspaneelen - zweiseitig • Structure portante avec bâti et panneaux de parement - 2 côtés Estructura portante tipo bastidor con paneles de cierre - 2 lados</p>	<p>3.059,00 x ml</p>



ESEMPIO DI PIANO COTTURA IGIENICO PASSANTE

EXAMPLE OF HYGIENIC PASS THROUGH CENTRAL COOKING BLOCK

Piani di cottura igienici e/o passanti,
disponibili su richiesta • Hygienic cooking
top and/or pass through central cooking
blocks are available on request • Kochfelder
für hohe Hygieneansprüche und/oder
beidseitig benutzbar auf Anfrage erhältlich
• Plans de cuisson hygiéniques et/ou
traversants, disponibles sur demande •
Placas de cocción higiénicas y/o pasantes,
disponibles por encargo

Pasticceria

Pastry line | Linie für Konditorei | Gamma pâtisserie | Línea pastelería

PPC ■ PRODOTTI PRONTA CONSEGNA

I prodotti contrassegnati con **PPC** sono disponibili alla spedizione in meno di 24h. • Products marked with **PPC** are available for shipment in less than 24 hours. • Mit **PPC** gekennzeichnete Produkte sind in weniger als 24 Stunden versandbereit. • Les produits marqués avec **PPC** sont disponibles pour l'expédition en moins de 24 heures. • Los productos marcados con **PPC** están disponibles para su envío en menos de 24 horas.



PFE1813

FRIGGITRICI DA TAVOLO
COUNTER FRYERS
TISCHFRITEUSEN
FRITEUSES POSABLES
FREIDORAS DE MESA

PFE1814

FRIGGITRICI DA TAVOLO
COUNTER FRYERS
TISCHFRITEUSEN
FRITEUSES POSABLES
FREIDORAS DE MESA

MFG1800

FRIGGITRICI A GAS DA TAVOLO
COUNTER GAS FRYERS
TISCHGASFRITEUSEN
FRITEUSES À GAZ POSABLES
FREIDORAS A GAS DE MESA

GIORIK
INNOVATIVE COOKING EQUIPMENT SINCE 1963

I dati del presente documento sono da ritenersi non vincolanti. Modifiche ai prodotti possono essere apportate senza preavviso dal costruttore • The manufacturer reserves the right to modify any product without prior notice • Die Daten dieser Beschreibung sind nicht als bindend anzusehen. Der Hersteller Kann ohne Vorankündigung Änderungen an den Produkten vornehmen • Des modifications aux produits peuvent être apportées sans préavis du constructeur • La casa se reserva el derecho de aportar a los aparatos las modificaciones que creera oportuno.

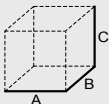

APPARECCHIATURE PER PASTICCERIA

PASTRY EQUIPMENT • GERÄTE FÜR BÄCKEREI
ÉQUIPEMENTS POUR PÂTISSERIE • APARATOS PARA PASTELERÍA

CODICE		VOL./PESO	GAS	VAC	VAC	CAPACITA'	PREZZO
Code Kode Code Codigo		Vol./Weight Vol./Gewicht Vol./Poids Vol./Pesos		230-1N 50/60 Hz	400-3N 50/60 Hz	Capacity Inhalt Capacité Capacidad	Price Preis Prix Precio
	(A x B x C) mm	m ³ /kg	kW	kW	kW	Lt.	€

Friggitrici su mobile • Cabinet fryers • Standfriteusen • Friteuses sur meuble • Freidoras sobre mueble





 FG73PT	800x700x900	0,8/102	17,5			44	3.606,00
 FG73PMT	800x700x900	0,8/102	17,5	0,1		44	4.226,00

Friggitrici da tavolo • Counter fryers • Tischfriteusen • Friteuses posables • Freidoras de mesa

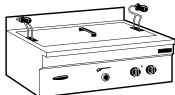
PPC



 PFE1813	700x580x250	0,23/31			6,8	21	1.992,00
 PFE1814	700x580x250	0,23/31			9	21	2.059,00
 PFE2713	1050x580x250	0,32/40			10	35	2.742,00

Friggitrici da tavolo • Counter fryers • Tischfriteusen • Friteuses posables • Freidoras de mesa

PPC

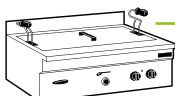

 MFG1800	700x580x250	0,24/48	12			18	2.605,00
--	-------------	---------	----	--	--	----	-----------------

I prezzi comprendono un cestello e una retina • Prices include a basket and a grille • Ein Korb und ein Gitter sind im Preis inbegriffen • Les prix comprennent un panier et une grille • Los precios incluyen un cesto y una rejilla



ELECTRONIC
MELTING CONTROL

ACCESSORI APPARECCHIATURE PER PASTICCERIA

ACCESSORIES FOR PASTRY EQUIPMENTS • ZUBEHÖR FÜR BÄCKEREIGERÄTEN
ACCESSOIRES POUR MATÉRIEL DE PÂTISSERIE • ACCESORIOS PARA APARATOS DE PASTELERÍA

CODICE Code Kode Code Codigo	VOL./PESO Vol./Weight Vol./Gewicht Vol./Poids Vol./Pesos	COMPATIBILITÀ Compatibility Kompatibilität Compatibilité Compatibilidad	PREZZO Price Preis Prix Precio
m ³ /kg			€
Supporti ed armadi neutri • Stands and neutral cupboards • Untergestellen und neutrale Schränke Supports et armoires neutres • Soportes y armarios neutros			
 SUF0620	mm 700x540x600H	0,33/12	PCG0200 - MFG1800 PFE1813 - PFE1814
SUF0630	mm 1050x540x600H	0,47/18	PCG0300 - PFE2713
 SUP0720	mm 700x540x600H	0,33/20	PCG0200 - MFG1800 PFE1813 - PFE1814
Cestelli • Baskets • Körbe • Paniers • Cestos			
2103013	mm 630x365x70		FG73PT - FG73PMT PFE1813 - PFE1814
 2104577	mm 580x320x70		MFG1800
2006871	mm 310x365x70		FG73PT - FG73PMT PFE1813 - PFE1814
2106619	mm 970x365x70		PFE2713
Sgocciolatoi • Draining boards • Korbablage • Égouttoirs • Escurrideros			
2001852	mm 765x390		FG73PT - FG73PMT
 2001882	mm 645x350		MFG1800
2001853	mm 767x392		PFE1813 - PFE1814
2001900	mm 1127x390		PFE2713
Retine anti-galleggio • No-floating nets • Hälterungsnetz • Grilles de retenue Redecillas recogida trozos flotantes			
 2106842	mm 940x330x47		PFE2713
2106843	mm 550x290x47		MFG1800
2106841	mm 603x330x47		FG73PT - FG73PMT PFE1813 - PFE1814
Vasche raccogli olio con filtro • Oil tanks with filter • Ölsammelwanne mit Filter Bacs de récupération huile avec filtre • Cubas recoge aceite con filtro			
 2010908			FG73PT - FG73PMT

Salamandre

Salamanders | Salamander | Salamandres | Salamandras

GIORIK
INNOVATIVE COOKING EQUIPMENT SINCE 1963







SALAMANDRE

SALAMANDRE RAPIDE

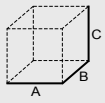

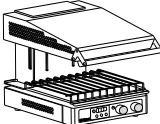
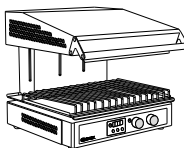
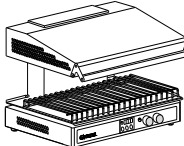
FAST SALAMANDERS • SCHNELLE SALAMANDER • SALAMANDRES RAPIDES
SALAMANDRAS RÀPIDAS

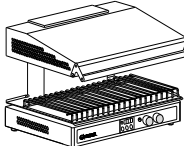

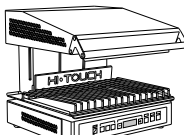
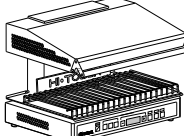
	CODICE Code Kode Code Codigo	 (A x B x C) mm	VOL./PESO Vol./Weight Vol./Gewicht Vol./Poids Vol./Pesos m³/kg	GAS kW	VAC 230-1N 50/60 Hz kW	VAC 400-3N 50/60 Hz kW	PREZZO Price Preis Prix Precio €
 Elettromeccanica • Electromechanical • Elektromechanischer • Électromécanique Electromecánica							
	SH20	400x545x515 390x300	0,19 / 43		3		1.914,00
	SH30	570x580x520 540x365	0,27 / 65			4,5	3.246,00
	SH40	735x580x520 700x365	0,38 / 80,5			5,3	3.898,00
 Elettromeccanica - Presenza piatto • Electromechanica - Plate detection system Elektromechanischer - Tellererkennung • Électromécanique - Présence plat Electromecánica - Detección de plato							
	SHP30	570x580x520 540x365	0,27 / 65			4,5	3.650,00
	SHP40	735x580x520 700x365	0,38 / 80,5			6	4.321,00
 Touch screen - Presenza piatto • Touch screen - Plate detection system • Touch screen - Tellererkennung • Touch screen - Présence plat • Touch screen - Detección de plato							
	ST30	570x580x520 540x365	0,27 / 65			4,5	3.870,00
	ST40	735x580x520 700x365	0,38 / 80,5			6	4.568,00

In dotazione mensola per fissaggio a muro • Wall brackets included • Wand Befestigung in der Ausstattung
Support mural en dotation • En dotación estante para fijación a pared

SALAMANDRE

SALAMANDERS • SALAMANDER • SALAMANDRES • SALAMANDRAS

CODICE		VOL./PESO	GAS	VAC	VAC	PREZZO
Code Kode Code Codigo		Vol./Weight Vol./Gewicht Vol./Poids Vol./Pesos		230-1N 50/60 Hz	400-3N 50/60 Hz	Price Preis Prix Precio
	(A x B x C) mm	m ³ /kg	kW	kW	kW	€

Salamandre • Salamanders • Salamander • Salamandres • Salamandras

 **SRE1410** 450x450x470 0,18 / 38 2,2 **1.496,00**

 **SRE1210** 650x480x570 0,33 / 64 3,9 **1.812,00**

 **SRE1231** 650x480x570 0,33 / 64 3,9 **1.812,00**

Salamandre • Salamanders • Salamander • Salamandres • Salamandras

 **SFG0800** 755x425x500 0,37 / 48 6 **1.800,00**

 **SRG2000** 630x380x580 0,25/40 5 **2.240,00**

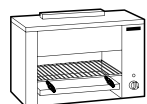
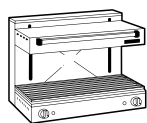

ACCESSORI PER SALAMANDRE

ACCESSORIES FOR SALAMANDERS • ZUBEHÖR FÜR SALAMANDER
ACCESSOIRES POUR SALAMANDRES • ACCESORIOS PARA SALAMANDRAS

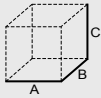
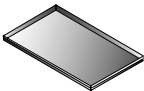
CODICE Code Kode Code Codigo		COMPATIBILITÀ Compatibility Kompatibilität Compatibilité Compatibilidad	PREZZO Price Preis Prix Precio	
(A x B x C) mm			€	
Mensole per fissaggio a muro • Wall brackets • Wand Befestigungen Supports mural • Estantes para fijación a pared				
2001928		SRE1410	15,00	
2001927		SRE1210-SRE1231	23,00	
2011679		SFG0800	100,00	
2005526		SRG2000	237,00	
2008038		SH30 - SHP30 SH40 - SHP40 ST30 - ST40	32,00	
2013890		SH20	16,00	
Bacinella raccogli gocce • Drip tray • Tropfwanne Bac d'égouttage • Bandeja colectora				
	2024287	630X405	SH30	49,00
	2024288	795x405	SH40	57,00
	2024289	460x348	SH20	39,00

DropIn

cottura modulare da incasso

Drop-in modular cooking range | Einbau-Modulkochlinie
Cuisson modulaire encastrable | Cocción modular empotrable

GIORIK
INNOVATIVE COOKING EQUIPMENT SINCE 1963

SISTEMA DI APPARECCHIATURE DA INCASSO,
per soddisfare ogni esigenza in cucina, sfruttando al massimo lo spazio e dando origine ad un incredibile numero di soluzioni.

A DROP-IN SYSTEM,
which satisfies every need in the kitchen exploiting in the best way the room and giving the possibility of a large number of solutions.

SYSTEM VON EINBAUGERÄTEN,
das erlaubt, jeder Anforderung beim Backen nachzukommen, wobei der Raum vollkommen ausgenützt wird, und welches vielfache Lösungen anbietet.

SYSTÈME D'APPAREILS DROP-IN,
qui permet de satisfaire chaque exigence de cuisson, utilisant au maximum l'espace et qui offre plusieurs solutions.

SISTEMA DE EQUIPOS EMPOTRABLES,
para satisfacer cualquier exigencia en la cocina, aprovechando al máximo el espacio y dando origen a un increíble número de soluciones.

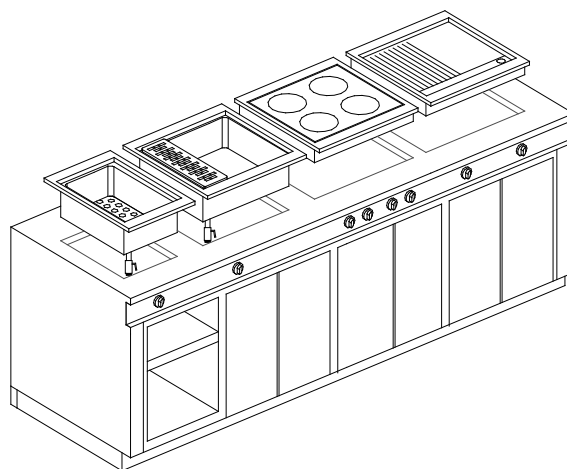

APPLICAZIONI
APPLICATION EXAMPLE
EINBAUBEISPIEL
EXEMPLE DE MONTAGE
APLICACIONES

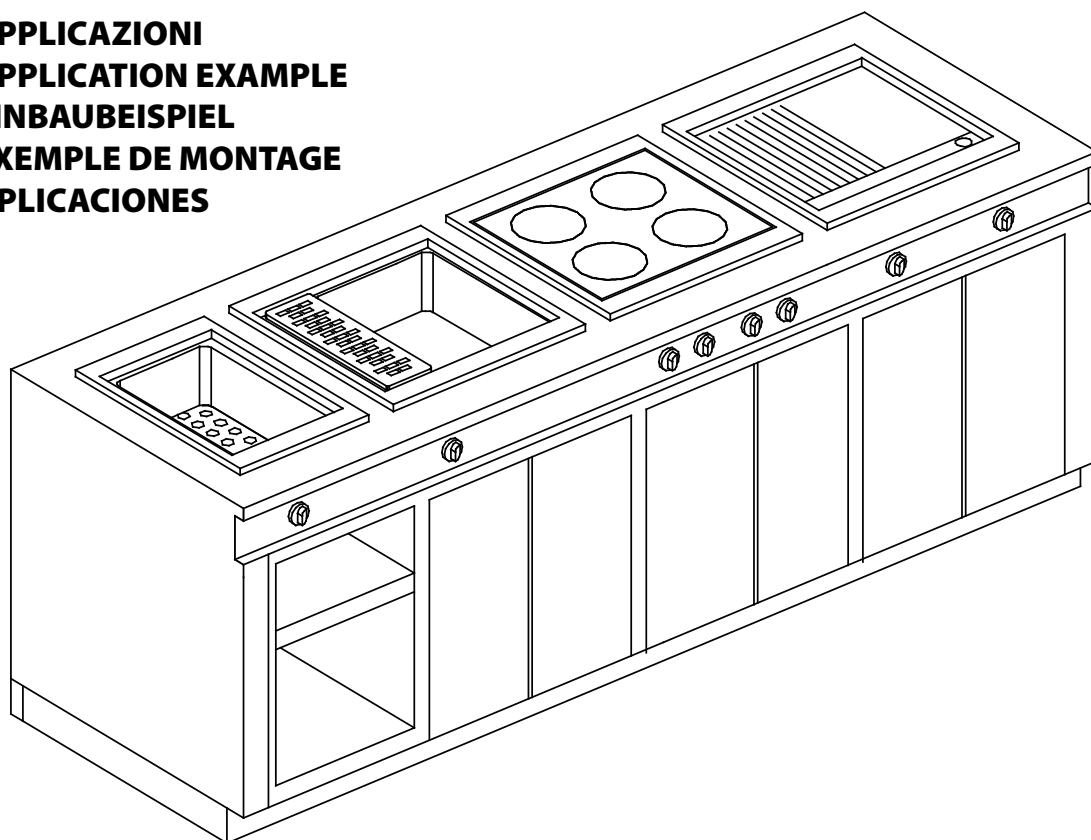

CUCINE A GAS

GAS RANGES • GASHERDE
FORNEAUX GAZ • COCINAS A GAS

CODICE Code Kode Code Codigo	 (A x B x C) mm	VOL./PESO Vol./Weight Vol./Gewicht Vol./Poids Vol./Pesos	GAS	VAC 230-1N 50/60 Hz	VAC 400-3N 50/60 Hz	PREZZO Price Preis Prix Precio
		m ³ /kg	kW	kW	kW	€

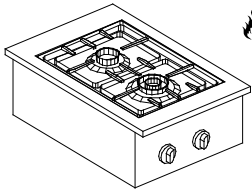

LPG4820D

400x557

0,18/20

9,5
1 x 3,5
1 x 6

1.045,00

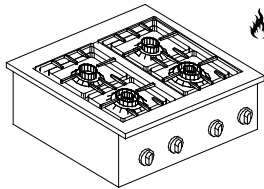

LPG6840D

600x557



0,25/30

19
2 x 3,5
2 x 6

1.599,00

CUCINE VETROCERAMICA

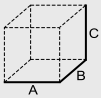
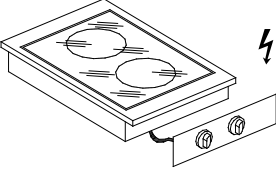
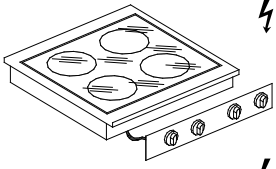
RANGES CERAMIC GLASS • HERDE GLASKERAMIK
PLAQUES DE CUISSON EN VITROCÉRAMIQUE • COCINAS VETROCERAMICA

CODICE Code Kode Code Codigo	 (A x B x C) mm	VOL./PESO Vol./Weight Vol./Gewicht Vol./Poids Vol./Pesos m ³ /kg	GAS kW	VAC 230-1N 50/60 Hz kW	VAC 400-3N 50/60 Hz kW	PREZZO Price Preis Prix Precio €
 LPV6421D	400x557 1 x Ø180 1 x Ø230	0,18/13		4,3 1 x 1,8kW 1 x 2,5kW		1.439,00
 LPV6841D	600x557 1 x Ø180 2 x Ø230 1 x Ø145	0,20/20		8 1 x 1,8kW 2 x 2,5kW 1 x 1,2kW		2.156,00
 LPV6861D	600x557 1 x Ø180 2 x Ø230 1 x Ø145	0,20/20		8 1 x 1,8kW 2 x 2,5kW 1 x 1,2kW		2.156,00

CUCINE ELETTRICHE CON PIASTRE ROTONDE

ELECTRIC RANGE WITH ROUND PLATES • ELEKTROHERDE MIT RUNDEN PLATTEN • FORNEAUX
ÉLECTRIQUES AVEC PLAQUES ARRONDIES • COCINAS ELÉCTRICAS CON PLANCHAS REDONDAS

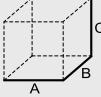
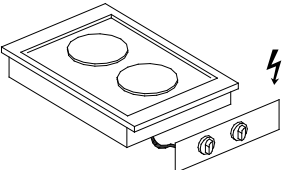
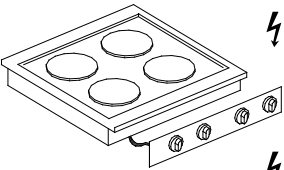
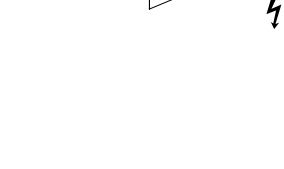
CODICE Code Kode Code Codigo	 (A x B x C) mm	VOL./PESO Vol./Weight Vol./Gewicht Vol./Poids Vol./Pesos m ³ /kg	GAS kW	VAC 230-1N 50/60 Hz kW	VAC 400-3N 50/60 Hz kW	PREZZO Price Preis Prix Precio €
 LPE6421D	400x557 2 x Ø180	0,18/20		4 2 x 2kW		658,00
 LPE6841D	600x557 4 x Ø180	0,20/15		8 4 x 2kW		881,00
 LPE6843D	600x557 4 x Ø180	0,20/15		8 4 x 2kW		881,00

FRY TOP ELETTRICI

ELECTRIC GRIDDLE PLATES • ELEKTRO-GRILLPLATTEN
GRILLADES ÉLECTRIQUES • FRY-TOP ELÉCTRICOS

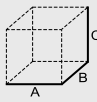
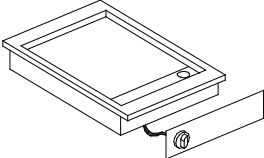
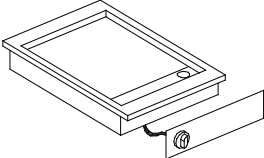
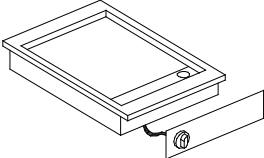
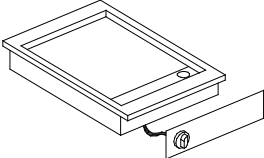
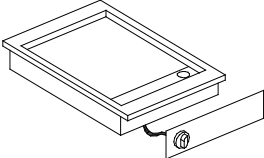
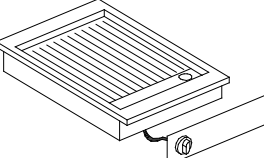
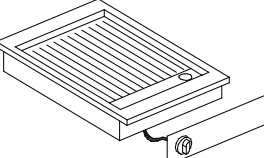
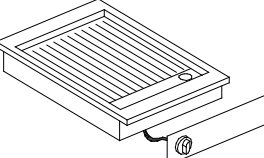
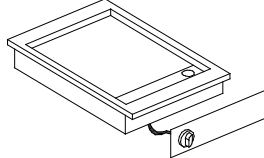
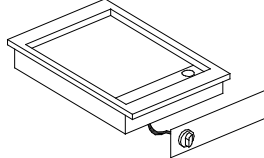
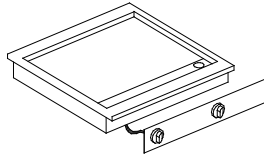
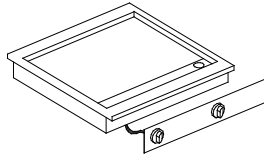
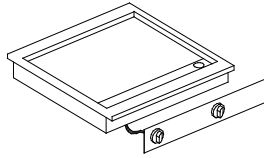
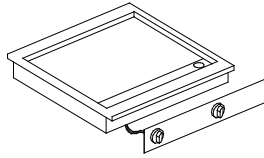
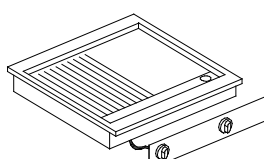
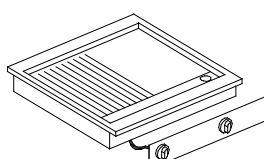
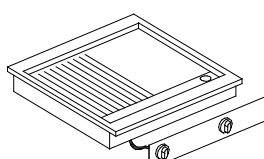
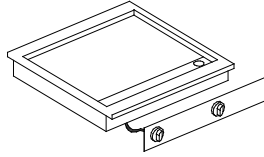
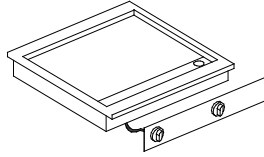
CODICE Code Kode Code Codigo		VOL./PESO Vol./Weight Vol./Gewicht Vol./Poids Vol./Pesos	GAS	VAC		PREZZO Price Preis Prix Precio
				230-1N 50/60 Hz	400-3N 50/60 Hz	
	(A x B x C) mm	m ³ /kg	kW	kW	kW	€
 LGE4801D	388x516	0,18/35		3,6		1.056,00
Non disponibile per la Comunità Europea • Not available for UE market						
 LGE4803D	388x516	0,18/35			3,6	1.056,00
Non disponibile per la Comunità Europea • Not available for UE market						
 LGE4801DX	388x516	0,18/35		3,6		1.259,00
 LGE4803DX	388x516	0,18/35			3,6	1.259,00
 LGE4811D	388x516	0,18/35		3,6		1.117,00
Non disponibile per la Comunità Europea • Not available for UE market						
 LGE4813D	388x516	0,18/35			3,6	1.117,00
Non disponibile per la Comunità Europea • Not available for UE market						
 LGE4811DX	388x516	0,18/35		3,6		1.293,00
 LGE4813DX	388x516	0,18/35			3,6	1.293,00
 LGE4831D*	388x516	0,18/35		3,6		1.438,00
 LGE4833D*	388x516	0,18/35			3,6	1.438,00
 LGE6801D	588x516	0,25/40		7,2		1.538,00
Non disponibile per la Comunità Europea • Not available for UE market						
 LGE6803D	588x516	0,25/40			7,2	1.538,00
Non disponibile per la Comunità Europea • Not available for UE market						
 LGE6801DX	588x516	0,25/40		7,2		1.804,00
 LGE6803DX	588x516	0,25/40			7,2	1.804,00
 LGE6821D	588x516	0,25/40		7,2		1.706,00
Non disponibile per la Comunità Europea • Not available for UE market						
 LGE6823D	588x516	0,25/40			7,2	1.706,00
Non disponibile per la Comunità Europea • Not available for UE market						
 LGE6821DX	588x516	0,25/40		7,2		1.908,00
 LGE6823DX	588x516	0,25/40			7,2	1.908,00
 LGE6831D*	588x516	0,25/40		7,2		2.112,00
 LGE6833D*	588x516	0,25/40			7,2	2.112,00

Non disponibile per la comunità Europea • Not available for UE market • Nicht erhältlich für die Europäische Gemeinschaft • Non disponible pour la Communauté européenne • No disponible para la Comunidad europea

X Piastra in acciaio inossidabile Duplex 2304 • Duplex 2304 stainless steel plate • Platte aus rostfreiem Stahl Duplex 2304 • Plaque en acier inoxydable Duplex 2304 • Placa de acero inoxidable Duplex 2304

* Versione con piastra cromata • Chrome-plated surface • Ausführung mit Chromplatte • Version avec plaque chromée • Versión con placha cromada



BAGNO MARIA

BAIN MARIES • BAIN-MARIES • BAIN-MARIE • BAÑO MARÍA

CODICE Code Kode Code Codigo	VOL./PESO Vol./Weight Vol./Gewicht Vol./Poids Vol./Pesos	GAS	VAC 230-1N 50/60 Hz	VAC 400-3N 50/60 Hz	PREZZO Price Preis Prix Precio
(A x B x C) mm	m ³ /kg	kW	kW	kW	€

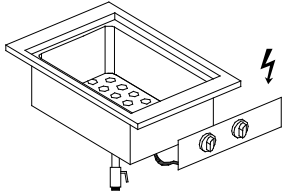

LBE4811D	400x557 GN 1/2 + GN 1/4	0,18/17		1,4	887,00
-----------------	----------------------------	---------	--	-----	---------------

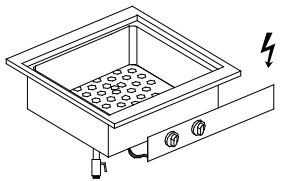

LBE6811D	600x557 GN 1/1 + 2 x GN 1/4	0,20/30		2,8	1.052,00
-----------------	--------------------------------	---------	--	-----	-----------------

CUOCIPASTA ELETTRICI

ELECTRIC PASTA COOKER • ELEKTRO NUDELKOCHER
CUISEIERS À PÂTE ÉLECTRIQUES • CUECE-PASTAS ELÉCTRICOS

CODICE Code Kode Code Codigo	VOL./PESO Vol./Weight Vol./Gewicht Vol./Poids Vol./Pesos	GAS	VAC 400-3N 50/60 Hz	CAPACITA' Capacity Inhalt Capacité Capacidad	PREZZO Price Preis Prix Precio
(A x B x C) mm	m ³ /kg	kW	kW	Lt.	€

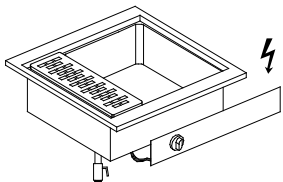
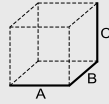

LCP6813D	600x557	0,50/35		5,5	26	2.031,00
-----------------	---------	---------	--	-----	----	-----------------

SCALDAPATATE

CHIPS SCUTTLES • POMMES FRITES-WÄRMER
BACS DE SALAGE • CALIENTA PATATAS

CODICE Code Kode Code Codigo	VOL./PESO Vol./Weight Vol./Gewicht Vol./Poids Vol./Pesos	VAC 230-1N 50/60 Hz	VAC 400-3N 50/60 Hz	CAPACITA' Capacity Inhalt Capacité Capacidad	PREZZO Price Preis Prix Precio
(A x B x C) mm	m ³ /kg	kW	kW		€

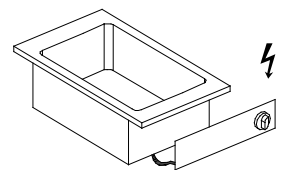
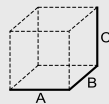

LSE4811D	400x557	0,18/15	1,4	Gn 2/3	816,00
-----------------	---------	---------	-----	--------	---------------

FRIGGITRICI ELETTRICHE

DropIn
600

ELECTRIC DEEP FAT FRYERS • ELEKTRO FRITEUSEN
FRITEUSES ÉLECTRIQUES • FREIDORAS ELÉCTRICAS

CODICE Code Kode Code Codigo	 (A x B x C) mm	VOL./PESO Vol./Weight Vol./Gewicht Vol./Poids Vol./Pesos	VAC 230-1N 50/60 Hz	VAC 400-3N 50/60 Hz	CAPACITA' Capacity Inhalt Capacité Capacidad	PREZZO Price Preis Prix Precio
		m³/kg	kW	kW	Lt.	€

Friggitrici con resistenze fisse • Fryers with fixed heating elements • Friteusen mit festen Widerständen
Friteuses avec résistances fixes • Freidoras con resistencias fijas

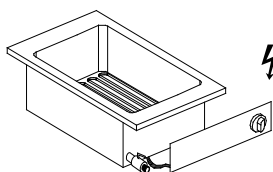

LFE4850D

400x557

0,18/18

3,3

6

1.058,00

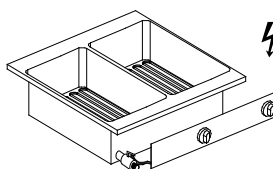

LFE6850D

600x557

0,22/25

6,6

6 + 6

1.859,00

Friggitrici con gruppo resistenze sollevabili • Fryers with liftable heating elements • Friteusen mit drehbaren Schaltkasten • Friteuses avec groupe résistances basculant • Freidoras con grupo de resistencias extraíbles

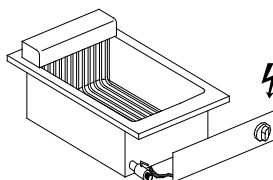

LFE4883D

400x557

0,18/20

6,3

8

1.369,00

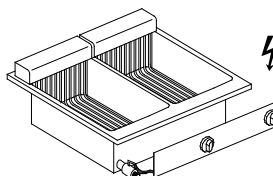

LFE6883D

600x557

0,22/25

12,6

8 + 8

2.444,00

CUCINE A GAS

GAS RANGES • GASHERDE
FORNEAUX GAZ • COCINAS A GAS

CODICE Code Kode Code Codigo		VOL./PESO Vol./Weight Vol./Gewicht Vol./Poids Vol./Pesos	GAS	VAC		PREZZO Price Preis Prix Precio
				230-1N 50/60 Hz	400-3N 50/60 Hz	
	(A x B x C) mm	m ³ /kg	kW	kW	kW	€

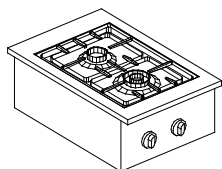

CG720D

400x600

0,2/15

12

1.340,00

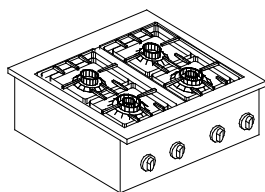

CG740D

800x600

0,4/30

24

2.367,00

CUCINE TUTTAPIASTRA

SOLID TOPS • GLÜHPLATTENHERDE
CUISINIÈRES COUP DE FEU • PLACAS RADIANTES

CODICE Code Kode Code Codigo		VOL./PESO Vol./Weight Vol./Gewicht Vol./Poids Vol./Pesos	GAS	VAC		PREZZO Price Preis Prix Precio
				230-1N 50/60 Hz	400-3N 50/60 Hz	
	(A x B x C) mm	m ³ /kg	kW	kW	kW	€

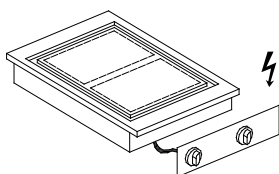

TE720D

400x600

0,35/25

4

1.879,00

CUCINE VETROCERAMICA

RANGES CERAMIC GLASS • HERDE GLASKERAMIK
PLAQUES DE CUISSON EN VITROCÉRAMIQUE • COCINAS VETROCERAMICA

CODICE Code Kode Code Codigo	 (A x B x C) mm	VOL./PESO Vol./Weight Vol./Gewicht Vol./Poids Vol./Pesos m ³ /kg	GAS kW	VAC 230-1N 50/60 Hz kW	VAC 400-3N 50/60 Hz kW	PREZZO Price Preis Prix Precio €
--	---	--	-----------	---------------------------------	---------------------------------	---

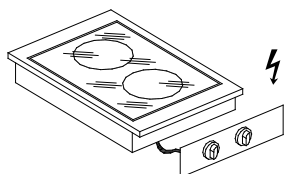

CV720D	400x600 2 x Ø230	0,2/15			4,2	1.664,00
---------------	---------------------	--------	--	--	-----	-----------------

CUCINA A INDUZIONE

INDUCTION RANGES • INDUKTIONSHERDE • PLAQUES DE CUISSON À INDUCTION
COCINAS ELECTRICAS A INDUCCION

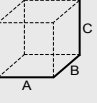
CODICE Code Kode Code Codigo	 (A x B x C) mm	VOL./PESO Vol./Weight Vol./Gewicht Vol./Poids Vol./Pesos m ³ /kg	GAS kW	VAC 230-1N 50/60 Hz kW	VAC 400-3N 50/60 Hz kW	PREZZO Price Preis Prix Precio €
--	--	--	-----------	---------------------------------	---------------------------------	---

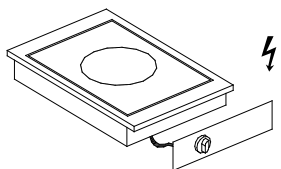

CI710D	400x600 1 x Ø230	0,2/15			5	5.395,00
---------------	---------------------	--------	--	--	---	-----------------

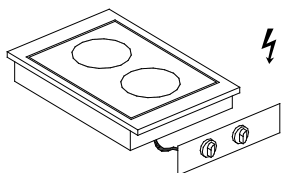

CI720D	400x600 2 x Ø230	0,2/30			7	7.925,00
---------------	---------------------	--------	--	--	---	-----------------

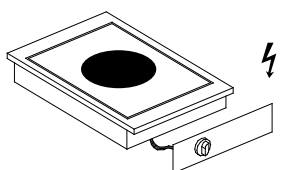

CW720D	400x600 1 x Ø300	0,2/25			5	6.561,00
---------------	---------------------	--------	--	--	---	-----------------

CUCINA ELETTRICA PIASTRE QUADRE

ELECTRIC RANGE WITH SQUARE PLATES • ELEKTROHERDE MIT VIERECKIGEN GUSSPLATTEN
FORNEAUX ÉLECTRIQUES AVEC PLAQUES CARRÉES • COCINAS ELÉCTRICAS CON PLANCHAS CUADRADAS

CODICE		VOL./PESO	GAS	VAC	VAC	PREZZO
Code		Vol./Weight		230-1N	400-3N	Price
Kode		Vol./Gewicht		50/60 Hz	50/60 Hz	Preis
Code		Vol./Poids				Prix
Codigo		Vol./Pesos				Precio
	(A x B x C) mm	m ³ /kg	kW	kW	kW	€

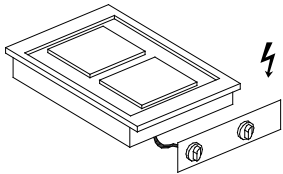

CE72QD	400x600	0,2/18			5,2	1.723,00
---------------	---------	--------	--	--	-----	-----------------

CUCINE ELETTRICHE CON PIASTRE ROTONDE

ELECTRIC RANGE WITH ROUND PLATES • ELEKTROHERDE MIT RUNDEN PLATTEN
FORNEAUX ÉLECTRIQUES AVEC PLAQUES ARRONDIES • COCINAS ELÉCTRICAS CON PLANCHAS REDONDAS

CODICE		VOL./PESO	GAS	VAC	VAC	PREZZO
Code		Vol./Weight		230-1N	400-3N	Price
Kode		Vol./Gewicht		50/60 Hz	50/60 Hz	Preis
Code		Vol./Poids				Prix
Codigo		Vol./Pesos				Precio
	(A x B x C) mm	m ³ /kg	kW	kW	kW	€

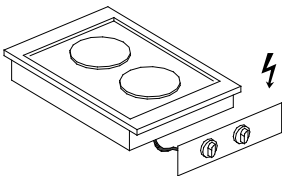

CE72TD	400x600	0,2/18			5,2	1.181,00
---------------	---------	--------	--	--	-----	-----------------

FRY TOP ELETTRICI

ELECTRIC GRIDDLE PLATES • ELEKTRO-GRILLPLATTEN
GRILLADES ÉLECTRIQUES • FRY-TOP ELÉCTRICOS

CODICE		VOL./PESO	GAS	VAC	CAPACITA'	PREZZO
Code		Vol./Weight		400-3N	Capacity	Price
Kode		Vol./Gewicht		50/60 Hz	Inhalt	Preis
Code		Vol./Poids			Capacité	Prix
Codigo		Vol./Pesos			Capacidad	Precio
	(A x B x C) mm	m ³ /kg	kW	kW	Lt.	€

Liscio • Smooth • Glatt • Lisse • Liso

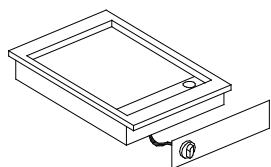

⚡	FLE72DF	400x600	0,4/25	6		1.764,00
	Non disponibile per la Comunità Europea • Not available for UE market					

⚡	FLE72DCRX	400x600	0,4/25	6		2.031,00
---	------------------	---------	--------	---	--	-----------------

Rigato • Ribbed • Gerillt • Nervuré • Acanalado

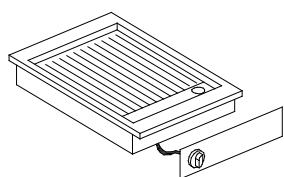

⚡	FRE72DF	400x600	0,4/25	6		1.816,00
	Non disponibile per la Comunità Europea • Not available for UE market					

⚡	FRE72DCRX	400x600	0,4/25	6		2.370,00
---	------------------	---------	--------	---	--	-----------------

F Piastra in ferro • Mild iron plate • Platte aus Eisen • Plaque en fer • Placa de hierro

Non disponibile per la comunità Europea • Not available for UE market • Nicht erhältlich für die Europäische Gemeinschaft • Non disponible pour la Communauté européenne • No disponible para la Comunidad europea

CRX Piastra in acciaio spessore 15 mm con finitura cromata satinata. Conforme al regolamento CE 1935/2004 riguardante materiali e oggetti a contatto con gli alimenti. Il materiale è antiaderente e garantisce resistenza alla corrosione e ai graffi. • Steel Chrome-plated satin finish, 15 mm thickness. In compliance with UE Regulation 1935/2004 on materials and articles in contact with food. The material is non-stick and guarantees resistance to corrosion and scratches. • Stahl Verchromt satiniert, 15 mm dick. • Acier chromé satiné, épaisseur 15 mm. • Acero Cromado satinado, 15 mm de espesor.



BRASIERE MULTIUSO

MULTI COOKING BRATT PANS • ELEKTRO MULTI-BRÄTER
MULTI-SAUTEUSE • SARTEN MULTIPLIO

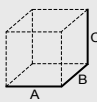
CODICE		VOL./PESO	GAS	VAC	CAPACITA'	PREZZO
Code		Vol./Weight		400-3N	Capacity	Price
Kode		Vol./Gewicht		50/60 Hz	Inhalt	Preis
Code		Vol./Poids			Capacité	Prix
Codigo		Vol./Pesos			Capacidad	Precio
	(A x B x C) mm	m ³ /kg	kW	kW	Lt.	€

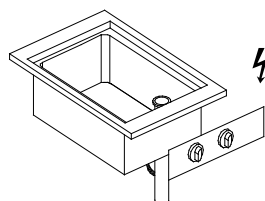

⚡	CM720D	400x600	0,4/25	5,1	12	3.211,00
---	---------------	---------	--------	-----	----	-----------------

BAGNO MARIA

BAIN MARIES • BAIN-MARIES • BAIN-MARIE • BAÑO MARÍA

CODICE		VOL./PESO	GAS	VAC	CAPACITA'	PREZZO
Code		Vol./Weight		230-1N	Capacity	Price
Kode		Vol./Gewicht		50/60 Hz	Inhalt	Preis
Code		Vol./Poids			Capacité	Prix
Codigo		Vol./Pesos			Capacidad	Precio
	(A x B x C) mm	m ³ /kg	kW	kW	Lt.	€

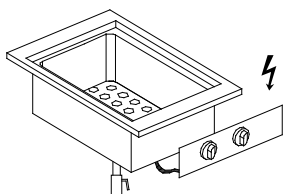

BM72ED
GN 1/1

400x600

0,4/13

1,1

1.640,00

CUOCIPASTA ELETTRICI

ELECTRIC PASTA COOKER • ELEKTRO NUDELKOCHER
CUISEIERS À PÂTE ÉLECTRIQUES • CUECE-PASTAS ELÉCTRICOS

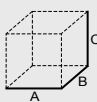
CODICE		VOL./PESO	GAS	VAC	CAPACITA'	PREZZO
Code		Vol./Weight		400-3N	Capacity	Price
Kode		Vol./Gewicht		50/60 Hz	Inhalt	Preis
Code		Vol./Poids			Capacité	Prix
Codigo		Vol./Pesos			Capacidad	Precio
	(A x B x C) mm	m ³ /kg	kW	kW	Lt.	€

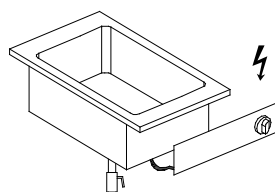

CPE726D

400x600

0,4/20

6,1

26

2.462,00

FRIGGITRICI ELETTRICHE

DropIn
700

ELECTRIC DEEP FAT FRYERS • ELEKTRO FRITEUSEN
FRITEUSES ÉLECTRIQUES • FREIDORAS ELÉCTRICAS

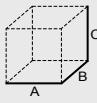
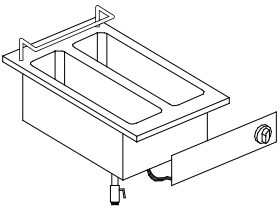
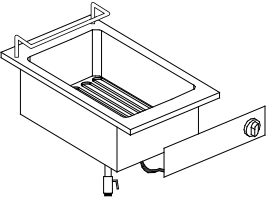
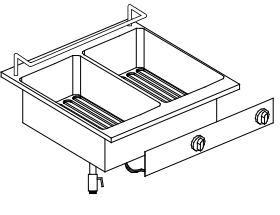
CODICE Code Kode Code Codigo	 (A x B x C) mm	VOL./PESO Vol./Weight Vol./Gewicht Vol./Poids Vol./Pesos	GAS	VAC 400-3N 50/60 Hz	CAPACITA' Capacity Inhalt Capacité Capacidad	PREZZO Price Preis Prix Precio
		m ³ /kg	kW	kW	Lt.	€
 ⚡ FE7207D	400x600	0,4/25		14	8 + 8	3.486,00
 ⚡ FE7113D	400x600	0,4/20		12	13	2.187,00
 ⚡ FE7213D	800x600	0,7/35		24	13 + 13	3.964,00

CONDIZIONI GENERALI DI VENDITA

PREZZI E MODALITÀ DI PAGAMENTO

I prezzi esposti in questo listino non comprendono:

- costi di trasporto
- installazione, montaggio, allacciamento
- I.V.A. (imposta sul valore aggiunto).

Le modalità di versamento del prezzo dei beni venduti sono le seguenti:

- 1) Pagamento con Rimessa Bancaria;
- 2) Pagamento Rateale;
- 3) Pagamento con lettera di credito per i clienti esteri.

In caso di mancato pagamento di anche una sola rata del prezzo - qualora sia concordata tra le parti una rateizzazione - l'acquirente decade dal beneficio del termine ed è pertanto tenuto all'immediata corresponsione dell'intero importo.

L'importo minimo fatturabile è pari a € 80,00 (netto, I.V.A. esclusa). Gli ordini che non raggiungono l'importo di € 150,00 (netto, comprensivo di trasporto ed I.V.A. esclusa) verranno evasi tassativamente con pagamento in contrassegno a mezzo corriere, porto franco c/addebito.

CONSEGNA

Il termine di consegna si intende normalmente in 4 settimane, salvo diversa indicazione della casa.

In ogni caso, eventuali ritardi nella consegna dovuti a fattori contingenti di produzione non potranno dare luogo a ritardi da parte dell'acquirente nel pagamento della merce fornita, se non espressamente pattuiti per iscritto tra le parti, né daranno diritto a sconti o comunque alla diminuzione del prezzo di listino.

DIRITTO DI RECESSO DALL'ACQUISTO

La normativa italiana che regola i contratti di vendita tra attività commerciali, nella fattispecie quella della venditrice e quella del rivenditore/distributore, non prevede la possibilità di recedere dal contratto di compravendita una volta che la merce sia stata consegnata.

Preghiamo pertanto i gentili clienti di:

- A) **verificare attentamente caratteristiche tecniche, dimensioni, peso e prezzo dell'articolo** scelto sul presente listino prima dell'ordine;
- B) **leggere attentamente la conferma d'ordine spedita via fax dalla venditrice**, confrontando i dati espressi sulla stessa e quelli del proprio ordine, affinché corrispondano esattamente a quello che si vuole acquistare;
- C) comunicare tempestivamente alla venditrice le discrepanze ed eventualmente le modifiche da apporre all'ordine.

Una volta consegnata la merce, il rapporto contrattuale viene considerato concluso, pertanto **la venditrice, da quel momento, non accetterà alcuna richiesta di reso, dovuta ad errato acquisto.**

RESA

La resa è da intendersi Franco stabilimento di Sedico caricato (**ex-works loaded**).

INTERESSI

Gli interessi, in caso di ritardato pagamento del prezzo, saranno automaticamente calcolati sulla base dell'Euribor 3 mesi più 5 punti percentuali, con decorrenza dal giorno della scadenza stabilita nelle condizioni di pagamento.

GARANZIA

La garanzia è di 24 mesi dalla data di fatturazione e copre i difetti che possono essere attribuiti ai materiali o alla fabbricazione che dovessero insorgere nel normale utilizzo dell'apparecchiatura. Durante il periodo di garanzia l'utente deve rivolgersi al rivenditore per qualsiasi segnalazione o reclamo. L'eventuale sostituzione di un pezzo nel periodo di garanzia non prolunga la durata della garanzia stessa oltre il limite iniziale. I pezzi in garanzia vengono spediti a carico e a rischio dell'acquirente.

La garanzia non viene riconosciuta in caso di installazione errata, nel caso di utilizzo di acqua sporca o aggressiva, in caso di presenza di calcare e di utilizzo di acqua non addolcita, nel caso in cui tensioni e frequenze di alimentazione siano diverse da quanto specificato in targhetta tecnica, nel caso, per le unità a gas, di utilizzo di gas inquinato o fuori specifica.

La garanzia non viene riconosciuta se il danno ha origini esterne all'apparecchio quali, ad esempio, sovratensioni di origine atmosferica. La garanzia non copre eventuali danni da trasporto.

La garanzia non viene riconosciuta in caso di cattivo utilizzo dell'apparecchiatura.

La garanzia sui materiali non viene riconosciuta nel caso di utilizzo di un detergente diverso da quello espressamente raccomandato.

Sono escluse dalla garanzia le parti di normale usura quali: le guarnizioni, le lampadine, i vetri interni delle porte.

La garanzia decade qualora la manutenzione venga fatta da personale non autorizzato o nel caso in cui vengano utilizzati ricambi non originali. La garanzia è valida solo nei confronti dell'acquirente originario.

ASSICURAZIONE CONTRO I RISCHI

In base all'art. 1 del D.P.R. 21/5/1988 n. 224.

In ottemperanza a quanto detto il nostro prodotto è assicurato contro i difetti di fabbricazione, errori di concezione o progettazione, difettoso imballo o confezionamento, errori di istruzione per l'uso a partire dal 01.01.1989.

STRALCIO DELLA POLIZZA DERIVANTE DAGLI OBBLIGHI DI LEGGE

L'assicurazione copre il costruttore contro: difetti di fabbricazione, errori di concezione o progettazione.

Il risarcimento deve essere per danni (capitale, interessi e spese) involontariamente cagionati a terzi dal prodotto difettoso dopo la consegna. La garanzia è prestata per i prodotti fabbricati, confezionati o importati in Italia, consegnati in qualsiasi Paese e per i sinistri ovunque verificatisi, con esclusione di U.S.A. e Canada.

DANNI SUL PRODOTTO DOVUTI AL TRASPORTO

Come comportarsi in caso di danni da trasporto:

- A) **DANNI EVIDENTI AGLI IMBALLI E ALLA MERCE CONTENUTA**
Il destinatario deve respingere al momento della consegna la merce, indicando sulla BOLLA DI SPEDIZIONE del trasportatore la dicitura **"merce danneggiata"**.
- B) **DANNI ALL'IMBALLO**
Procedere alla verifica e seguire la procedura sopra descritta (punto a). Nel caso la verifica non sia possibile in contemporanea alla consegna, apporre sulle bolle (di trasporto e di consegna) la dicitura **"riserva di controllo"**. Il controllo dello stato della merce deve avvenire **entro tre giorni** dalla consegna. Questo è un diritto previsto dalla legge. In caso di avaria, parziale o totale, deve esserne data comunicazione con **lettera raccomandata "A.R." (o fax)** al trasportatore ed, in fotocopia, via fax alla venditrice, indicando se il danno è totale o parziale.
- C) **AVARIA NON RICONOSCIBILE: DANNI OCCULTI**
In questo caso, la Legge 450/85, Art. 1698, prevede l'ammissione al rimborso purchè il danno venga denunciato appena conosciuto con lettera raccomandata "A.R." (o fax) al trasportatore, in copia alla venditrice e comunque **entro e non oltre otto giorni** dal ricevimento.

Quando non respinta al momento della consegna, la merce riconosciuta danneggiata deve essere rispedita, previo accordo con la venditrice, al nostro stabilimento di Sedico con LA CAUSALE "reso per danni da trasporto" e con MODALITÀ di CONSEGNA "trasporto in conto servizio", completa di ogni accessorio, nessuno escluso e con lo stesso trasportatore della consegna. In mancanza di quanto sopra indicato, non saranno accettati reclami tardivi od incompleti. La merce sarà considerata regolarmente consegnata ed accettata senza riserve, liberando il trasportatore dai suoi obblighi, ciò in conformità agli obblighi del ricevente.

Le merci a noi segnalate via fax inserite nelle procedure descritte nei casi a + b + c, verranno **rispedite** ai clienti che ne faranno richiesta **sempre e solo in vendita.**

La venditrice procederà alla emissione della **"nota di accredito"** a compensazione, parziale o totale, delle merci danneggiate solo dopo aver verificato il rispetto delle procedure pretese dalla Legge 450/85 e dopo aver ricevuto al proprio magazzino di Sedico la merce in causa ed aver verificato con il perito del trasportatore la veridicità della denuncia contenuta nella raccomandata "A.R." (o fax) inviata dal cliente.

GENERAL SALES CONDITION

PRICES AND PAYMENT TERMS

The prices shown in this list are ex works and do not include:

- carriage
- installation charges
- V.A.T.

The standard payment terms for the foreign markets are: confirmed and irrevocable documentary credit (L/C) and/or payment in advance. The minimum order value acceptable is € 150,00 (net, V.A.T. excluded). All orders that do not reach the amount of € 200,00 (net, transport included, V.A.T. excluded) will only be shipped with payment against document (C.O.D.) or anticipated wire transfer, shipping charges on invoice.

DELIVERY TERMS

The delivery time is normally 4 weeks from order confirmation or from letter of credit notification date.

Giorik reserves the right to alter these terms according to production requirements.

Should any delivery schedule be postponed, due to production events, neither any posticipation in payment by the client, unless previously agreed with a written notice between the two parties, nor any special discount nor price list decrease will be accepted.

Delivery is meant **incoterm 2000 ex-works loaded** c/o Giorik factory Sedico - BL (Italy).

RIGHT OF PURCHASE WITHDRAWAL

The Italian Code ruling sale contracts between business companies, i.e. the seller and the agent/distributor, does not provide for a right of withdrawal from a sale contract after the merchandise has been delivered.

Therefore, we kindly ask our customers to:

- attentively check technical features, dimensions, weight and price of items** on the current price list prior to ordering;
- attentively read the order confirmation faxed back by the seller**, comparing the details on the latter with those on the order, so that they meet customer requirements;
- immediately report any discrepancies or order changes to the seller.

Contract relations are considered as finished once the merchandise has been delivered. **From then on, the seller will accept no return claim due to a wrong purchase.**

INTEREST

Interests, in case of delayed payment of the goods, will be automatically charged on customer's account, based on Euribor 3 months value + 5%, and they are chargeable from the day after the due date.

GUARANTEE

The guarantee is for 24 months from the invoice date and it covers any defects that are attributable to the materials or manufacture of the equipment and that are revealed during normal use. While the guarantee is in force, users must address any comments or complaints to the retailer. If any parts have to be replaced under guarantee, this will not prolong the guarantee period beyond the original limit. Parts under guarantee are sent at the purchaser's risk and expense.

The guarantee does not apply in the event of faulty installation, use of dirty or hard water, if it contains lime scale or has not been softened, if the voltage and power frequency are other than as specified on the technical specification plate, and, for gas appliances, if the gas used is contaminated or does not meet the specification.

The guarantee does not apply if the damage is due to external circumstances, for example if it is caused by power surges of an atmospheric origin.

The guarantee does not apply to any damage caused during transport.

The guarantee does not apply if the equipment has been used improperly.

The guarantee covering materials does not apply if detergents are used other than those expressly recommended.

The guarantee does not cover parts subject to normal wear and tear: seals, light bulbs, glass panels inside doors.

The guarantee is invalidated if maintenance is performed by non-approved personnel or if non-original parts have been used.

The guarantee only extends to the original purchaser.

PUBLIC LIABILITY INSURANCE

Based on the article 1 of the D.P.R. 21/5/1988 no. 224 (Italy).

Starting from 01.01.1989 and in compliance with the above-mentioned, our product is insured against defects in manufacture, errors design, faulty packing or errors in directions for installation and use.

EXTRACT OF THE INSURANCE CONTRACT DERIVING FROM LEGAL OBLIGATIONS

The insurance covers the manufacturer for: manufacturing defects, designing errors, faulty packing or errors in directions for installation and use.

The indemnity for damages (capital, interests and costs) involuntarily caused to a third party after delivery by a faulty product.

The guarantee is given for products which are manufactured, assembled in Italy or imported into Italy, shipped in any country and for accidents wherever they may occur, U.S.A. and Canada not included.

FREIGHT DAMAGE POLICY

Procedure to be carried out in case of freight damage:

- VISUAL DAMAGE TO PACKAGING AND GOODS CONTAINED**
The receiver must return the goods to the carrier on delivery and note **"damaged items"** on the carrier's delivery receipt.
- DAMAGE TO PACKAGING**
Inspect the package and proceed as in paragraph "A" above. If it is not possible to inspect the package in the presence of the carrier, write "subject to inspection" on both the shipping bill and the delivery receipt. The items so delivered **must be checked within three days of delivery**. This is a term established by law. In case of damage, be it partial or total, the claim must be made with the carrier by **registered mail with return notice (or fax)**, and sent cc to the seller, indicating whether the damage is total or partial.
- UNDETECTED DAMAGE: HIDDEN DAMAGE**
In this case, the Italian Law 450/85, Art. 1698, provides for refund if the damage is claimed as soon as detected, by registered mail with return notice (or fax), and a copy of the claim is sent to the seller, **within eight days of delivery**.

When not returned to the carrier on delivery, the items acknowledged as damaged must be sent (with prior agreement with the seller only) to our Sedico factory by the same carrier, indicating as re.: "returned due to freight damage" and as delivery terms: "sent for servicing purposes". All accessories must be attached, none excluded. Failure to comply with the requirements above **will determine rejection of late or incomplete claims**. In this case the items will be considered as duly delivered and unconditionally accepted, and this will relieve the carrier from any further obligation.

When claims are reported to us by fax following the procedure in cases A + B + C above, the items will be returned to the customers upon their request, **on sales terms only**.

The seller will then issue a **"credit note"** as partial or total compensation for the damaged items, only after ensuring that the procedure established by the Italian Law 450/85 has been complied with and after the carrier's surveyor has assessed that the claim sent by registered mail with return notice (or by fax) is true and faithful.

ALLGEMEINE VERKAUFSBEDINGUNGEN

PREISE UND ZAHLUNGSMODALITÄTEN

Die in dieser Liste aufgestellten Preise sind berechnet ohne:

- Transportkosten
- Installation, Montage, Anschlüsse
- MWSt. (Mehrwertsteuer).

Die Überweisung des Betrages für die verkauften Güter sind folgend:

- 1) Zahlung durch Banküberweisung;
- 2) Ratenzahlung;
- 3) Zahlung mit Kreditbrief für Auslandskunden.

Bei nicht erfolgter Zahlung von nur einer Rate verfällt - sofern eine Rateneinteilung zwischen den Parteien vereinbart wurde - für den Käufer der Vorteil der Bedingung, und er ist daher zur sofortigen Zahlung des gesamten Betrages verpflichtet.

Der Mindestberechnungs Betrag entspricht € 150,00 (Netto, ohne MWSt.). Die Aufträge, die nicht den Betrag von € 200,00 (Netto, einschließlich Transport und ausschließlich MWSt.) erreichen, werden ausdrücklich per Nachnahme durch einen Eilboten, frei Haus mit transportkosten berechnet.

LIEFERUNG

Der Liefertermin beträgt normalerweise 4 Wochen, falls keine andere Angabe des Betriebs vorliegt.

Auf jeden Fall dürfen eventuelle Lieferverzögerungen aufgrund zwingender Produktionsfaktoren nicht zu Zahlungsverzögerungen der gelieferten Ware seitens des Käufers führen, falls sie nicht ausdrücklich schriftlich zwischen den Parteien vereinbart wurden; sie geben auch kein Recht auf Skonto oder auf eine Reduzierung des Listenpreises.

VERKAUFSRÜCKTRITTSRECHT

Das italienische Gesetz, das die Verkaufsverträge zwischen Handelsbetrieben regelt, sieht für den vorliegenden Fall des Verkäufers und Wiederverkäufers/Verteilers nicht die Möglichkeit vor, vom Kaufvertrag zurückzutreten, wenn die Ware einmal ausgeliefert wurde.

Daher bitten wir die Kunden:

- A) **die technischen Merkmale, Abmessungen, Gewicht und Preis** des in der vorliegenden Liste gewählten Artikels vor dem Kauf **aufmerksam zu überprüfen**;
- B) **die über Fax an den Verkäufer gesendete Auftragsbestätigung aufmerksam durchzulesen** und die hier ausgedrückten Daten mit den entsprechenden Auftragsdaten zu vergleichen, damit sie genau dem entsprechen, was Sie kaufen wollen;
- C) dem Verkäufer umgehend die Unterschiede und die eventuell am Auftrag auszuführenden Änderungen mitzuteilen.

Nach Auslieferung der Ware wird das Vertragsverhältnis als abgeschlossen betrachtet, daher akzeptiert **der Verkäufer von dem Moment an keine Anforderung für Rückerstattung, die auf einen irrtümlichen Kauf zurückzuführen ist.**

RÜCKERSTATTUNG

Die Rückerstattung versteht sich frei Werk Sedico, geladen (**ex-works loaded**).

VERZUGSZINSEN

Bei verzögerter Zahlung des Betrages werden die Verzugszinsen automatisch auf der Grundlage des Euribor 3 Monate plus 5 Prozentpunkte ab dem in den Zahlungsbedingungen festgelegten Verfalltag berechnet.

GARANTIE

Die Gewährleistung gilt für 24 Monate ab dem Datum der Rechnungsstellung und deckt Mängel, die dem Material oder der Verarbeitung zugeschrieben werden können und während des normalen Gebrauchs des Geräts entstehen. Während der Gewährleistung muss sich der Anwender für jegliche Meldungen oder Beanstandungen an den Händler wenden. Der etwaige Ersatz eines Bauteils während der Gewährleistung führt nicht zur Verlängerung der Gewährleistung über die ursprüngliche Frist hinaus. Für den Versand der Bauteile unter Gewährleistung trägt der Kunde die Kosten und das Risiko.

Die Gewährleistung entfällt infolge unsachgemäßer Installation, der Verwendung von schmutzigem oder aggressivem Wasser, bei Kalkvorkommen und der Nutzung von nicht enthartetem Wasser, wenn die gegebenen Stromversorgungsspannungen und -frequenzen von den Angaben auf dem Datenschild abweichen sowie im Falle von Gaseinheiten, infolge der Verwendung von verunreinigtem oder nicht entsprechendem Gas.

Die Gewährleistung gilt nicht, wenn der Schaden auf geräteexterne Ursachen, zum Beispiel auf Überspannung atmosphärischen Ursprungs zurückzuführen ist.

Die Gewährleistung deckt keine etwaigen Transportschäden.

Die Gewährleistung gilt nicht im Falle einer fehlerhaften Benutzung des Geräts.

Die Gewährleistung auf das Material gilt nicht, wenn ein anderes Reinigungsmittel als das ausdrücklich empfohlene benutzt wird.

Von der Gewährleistung ausgeschlossen sind Teile, die einem normalen Verschleiß unterliegen: Dichtungen, Leuchtmittel, Türinnenscheiben.

Die Gewährleistung verfällt, wenn die Wartung durch nicht autorisiertes Personal erfolgt oder im Falle der Benutzung von nicht originalen Ersatzteilen. Die Gewährleistung gilt nur gegenüber dem ursprünglichen Käufer.

GEFAHRENSICHERUNG

Aufgrund des Art. 1 des Erlasses des Bundespräsidenten (D.P.R.) 21.5.1988 Nr. 224.

Infolge der oben genannten Erklärung ist unser Produkt ab 01.01.1989 gegen Herstellungsfehler, Konzeptions- oder Planungsfehler, defekte Verpackung oder Verpackungsmaterial, Gebrauchsanleitungsfehler versichert.

AUSZUG DER VERSICHERUNGSVERTRAGES AUFGRUND DER GESETZLICHEN VERPFLICHTUNGEN

Die Versicherung deckt den Hersteller gegen: Herstellungsfehler, Konzeptions- oder Planungsfehler.

Der Schadensersatz erfolgt für Schäden (Kapital, Zinsen und Ausgaben), die Dritten versehentlich nach der Auslieferung durch das defekte Produkt entstanden sind.

Die Garantie wird für in Italien hergestellte, verpackte oder importierte Produkte, die in ein beliebiges Land ausgeliefert wurden und für an jedem beliebigen Ort erfolgte Unfälle geleistet, mit Ausschluss von USA und Canada

DURCH DEN TRANSPORT AM PRODUKT VERURSACHTE SCHÄDEN

Verhaltensweise im Falle von Transportschäden:

- A) **OFFENSICHTLICHE SCHÄDEN AN DER VERPACKUNG UND DEN DARIN ENTHALTENEN WAREN**
Der Empfänger muss bei Auslieferung die Ware zurückweisen und auf dem LIEFERSCHEIN des Lieferanten die Aufschrift **"Ware beschädigt"** angeben.
- B) **SCHÄDEN AN DER VERPACKUNG**
Überprüfen und den oben beschriebenen Vorgang befolgen (Punkt A). Sollte die Prüfung zur Lieferzeit nicht möglich sein, muss auf dem Lieferschein (Transport und Auslieferung) die Aufschrift **"Kontrolle vorbehalten"** angebracht werden. Die Kontrolle des Warenzustandes muss innerhalb von drei Tagen nach Auslieferung erfolgen. Das ist ein vom Gesetz vorgesehenes Recht. Im Falle eines teilweisen oder vollständigen Defekts muss dieser per Einschreibebrief **"mit Rückschein" (oder Fax)** an den Lieferanten und per Kopie über Fax an den Verkäufer mitgeteilt werden, wobei anzugeben ist, ob es sich um einen vollständigen oder teilweisen Schaden handelt.
- C) **NICHT ERKENNBARE DEFEKTE: VERSTECKTE SCHÄDEN**
In diesem Fall sieht das Gesetz 450/85 1698 die Zulassung der Rückzahlung vor, sofern der Schaden dem Lieferanten sofort nach Erkennung per Einschreibebrief „mit Rückschein“ (oder Fax) und dem Verkäufer per Kopie auf jeden Fall innerhalb von **acht Tagen** nach Erhalt mitgeteilt wird.

Wenn die Ware, die als beschädigt herausgestellt wird, nicht bei Auslieferung zurückgewiesen wird, muss sie nach vorheriger Vereinbarung mit dem Verkäufer unserem Werk in Sedico mit DEM VERMERK "Rückerstattung wegen Transportschäden" und mit der a "Transport in Betriebskonto" mit allem Zubehör ohne Ausschluss mit demselben Lieferanten der Auslieferung zurückgesendet werden. Fehlen die oben erwähnten Angaben, werden verspätete oder unvollständige Reklamationen nicht akzeptiert. Die Ware wird als ordnungsgemäß ausgeliefert und ohne Vorbehalt akzeptiert angesehen, wobei der Lieferant entsprechend den Verpflichtungen des Empfängers von seinen Verpflichtungen befreit wird.

Die Waren, die uns über Fax angezeigt werden und in die in den Fällen A + B + C beschriebenen Verfahren eingesetzt werden, werden den Kunden, die diese jeweils **nur beim Verkauf anfragen, wieder zurückgesendet.** Der Verkäufer stellt die **"Gutschrift"** zum teilweisen oder vollständigen Ausgleich der beschädigten Waren nur aus, nachdem er die Beachtung der vom Gesetz 450/85 vorgeschriebenen Verfahren überprüft und in seinem Lager in Sedico die betroffene Ware erhalten sowie mit dem Sachverständigen des Lieferanten die Wahrheit der Anzeige des Einschreibebriefs „mit Rückschein“ (oder Fax), der vom Kunden gesendet wurde, überprüft hat.

CONDITIONS GÉNÉRALES DE VENTE

PRIX ET MODALITÉS DE PAIEMENT

Les prix indiqués dans ce tarif ne comprennent pas :

- coûts de transport
- installation, montage, branchement
- TVA (taxe sur la valeur ajoutée).

Les modalités de versement du montant des biens vendus sont les suivantes :

- 1) Paiement par virement bancaire ;
- 2) Paiement à tempérament ;
- 3) Paiement par lettre de crédit pour les clients étrangers.

En cas de non-paiement même d'un seul versement du montant - si un échelonnement de paiement est déterminé entre les parties - l'acheteur déchoit du bénéfice du délai et il est donc tenu au paiement immédiat du montant total.

Le montant minimum de facturation est de € 150,00 (net, hors TAXE). Les commandes qui n'atteignent pas le montant de € 200,00 (net, transport compris et hors TAXE) seront formellement réglées par paiement contre-remboursement (à la livraison) par l'intermédiaire d'un transporteur, franco de port.

LIVRAISON

Le délai de livraison est normalement de 4 semaines, sauf indication différente de la maison.

Dans tous les cas, les éventuels retards de livraison dus à des facteurs contingents survenus lors de la production ne pourront pas donner lieu à des retards de paiement de la marchandise fournie, de la part de l'acheteur, sauf en cas d'accord expressément établi par écrit entre les parties, et ils ne donneront pas droit à des réductions ou à la diminution du prix catalogue.

DROIT DE RENONCIATION À L'ACHAT

La réglementation italienne qui règle les contrats de vente entre activités commerciales, dans le cas d'espèce, celui du vendeur et celui du revendeur/distributeur, ne prévoit pas la possibilité de renoncer au contrat d'achat et vente lorsque la marchandise a été livrée.

Nous prions donc notre aimable clientèle de :

- A) **vérifier attentivement les caractéristiques techniques, les dimensions, le poids et le prix de l'article** choisi sur le présent tarif avant la commande ;
- B) **lire attentivement la confirmation de commande envoyée par fax par le vendeur**, en comparant les données indiquées sur ce dernier et celles de sa propre commande, pour qu'elles correspondent exactement à ce que l'on souhaite acheter ;
- C) communiquer rapidement les différences au vendeur et les éventuelles modifications à apporter à la commande.

Une fois la marchandise livrée, le rapport contractuel est considéré comme achevé, à partir de ce moment, **le vendeur n'acceptera donc aucune demande de restitution, due à une erreur d'achat.**

INCOTERMS

La livraison s'entend départ usine de Sedico chargé (**ex-works loaded**).

INTÉRÊTS

Les intérêts, en cas de retard de paiement, seront automatiquement calculés sur la base de l'Euribor 3 mois plus 5%, à partir du jour de la date limite de paiement établi dans les conditions de paiement.

GARANTIE

La garantie a une durée de 24 mois à compter de la date de facturation et couvre les défauts attribuables aux matériaux ou à la fabrication qui pourraient surgir durant l'utilisation normale de l'appareil. Pendant la période de garantie, l'utilisateur devra s'adresser au revendeur pour toute communication ou réclamation. Le remplacement éventuel d'une pièce durant la période de garantie ne prolonge pas la durée de cette dernière au-delà de la limite initiale. Les pièces sous garantie sont expédiées aux risques et frais de l'acquéreur.

La garantie n'est pas reconnue en cas d'installation erronée, en cas d'utilisation d'eau sale ou agressive, en cas de présence de calcaire et d'utilisation d'eau non adoucie, dans le cas où les tensions et fréquences d'alimentation diffèrent des spécifications sur la plaquette technique, et pour les unités à gaz, en cas d'utilisation de gaz pollué ou non conforme.

La garantie n'est pas reconnue si le dommage a des origines externes à l'appareil, telles que, par exemple, des surtensions d'origine atmosphérique.

La garantie ne couvre pas d'éventuels dommages causés par le transport. La garantie n'est pas reconnue en cas d'utilisation inappropriée de l'appareil.

La garantie sur les matériaux n'est pas reconnue en cas d'utilisation d'un détergent autre que celui expressément recommandé.

Les parties sujettes à une usure normale, telles que les garnitures, les ampoules, les vitres internes des portes, sont exclues de la garantie.

La garantie déchoit si l'entretien est effectué par du personnel non autorisé ou en cas d'utilisation de pièces de rechange non d'origine.

La garantie n'est valide qu'à l'égard de l'acquéreur d'origine.

ASSURANCE CONTRE LES RISQUES

Conformément à l'art. 1 du D.P.R. 21/5/1988 n° 224.

Conformément à cet article, notre produit est assuré contre les défauts de fabrication, les erreurs de conception ou de projet, d'emballage ou de conditionnement défectueux, les erreurs de mode d'emploi à partir du 01.01.1989.

EXTRAIT DE LA POLICE DÉRIVANT DES OBLIGATIONS LÉGALES

L'assurance couvre le constructeur contre : les défauts de fabrication, les erreurs de conception ou de projet.

Les dommages et intérêts doivent correspondre à des dommages (capital, intérêts et frais) involontairement causés à des tiers par le produit défectueux, après la livraison.

La garantie est prévue pour les produits fabriqués, emballés ou importés en Italie, livrés dans n'importe quel Pays et pour des sinistres s'étant vérifiés n'importe où, avec exclusion de USA et Canada.

DOMMAGES SUR LE PRODUIT DUS AU TRANSPORT

Comment se comporter en cas de dommages provoqués par le transport :

- A) **DOMMAGES ÉVIDENTS SUR LES EMBALLAGES ET SUR LA MARCHANDISE EMBALLÉE**
Le destinataire doit refuser la marchandise au moment de la livraison, en indiquant sur le BORDEREAU DE LIVRAISON du transporteur la mention "**marchandise endommagée**".
- B) **DOMMAGES SUR L'EMBALLAGE**
Procéder à la vérification et suivre la procédure indiquée ci-dessus (point A). S'il est impossible de vérifier pendant la livraison, apposer la mention "**sous réserve de contrôle**" sur les bordereaux (de transport et de livraison). Le contrôle de l'état de la marchandise doit se faire **sous trois jours** à compter de la date de livraison. Ceci est un droit prévu par la loi. Toute avarie, partielle ou totale, doit être communiquée **par lettre recommandée avec accusé de réception (ou fax)** au transporteur et, par photocopie, par fax au vendeur, en indiquant si le dommage est total ou partiel.
- C) **AVARIE NON DISCERNABLE : VICES CACHÉS**
Dans ce cas, la Loi 450/85, Art. 1698, prévoit l'admission au remboursement pourvu que le dommage soit déclaré dès qu'il est repéré par lettre recommandée avec accusé de réception (ou fax) au transporteur, avec copie au vendeur et dans tous les cas **sous huit jours** à compter de la date de réception de la marchandise.

Lorsqu'elle n'est pas refusée lors de la livraison, la marchandise reconnue comme endommagée doit être réexpédiée, après accord avec le vendeur, à notre usine de Sedico avec LE MOTIF "rendu pour dommages transport" et avec le MODE de LIVRAISON "transport en compte service", avec tous les accessoires, sans en omettre aucun, et avec le même transporteur que pour la livraison. En l'absence des modalités indiquées ci-dessus, les réclamations tardives ou incomplètes ne seront pas acceptées. La marchandise sera considérée comme régulièrement livrée et acceptée sans réserve, en libérant le transporteur de ses obligations, c'est-à-dire conformément aux obligations du receveur.

Les marchandises nous ayant été signalées par fax comme dans les procédures décrites aux points A + B + C, **seront réexpédiées** aux clients qui en feront la demande **toujours et exclusivement en vente.**

Le vendeur émettra "la note de crédit" en compensation, partielle ou totale, des marchandises endommagées uniquement après avoir vérifié le respect des procédures fixées par la Loi 450/85 et après avoir reçu la marchandise en cause, dans son entrepôt de Sedico, et avoir vérifié avec un expert du transporteur la véracité de la déclaration contenue dans la lettre recommandée avec accusé de réception (ou fax) envoyée par le client.

CONDICIONES GENERALES DE VENTA

PRECIOS Y MODALIDAD DE PAGO

Los precios contenidos en esta lista no incluyen:

- los gastos de transporte
- la instalación, el montaje y la conexión
- el I.V.A. (impuesto sobre el valor añadido).

Las modalidades de pago del precio de los bienes vendidos pueden ser las siguientes:

- 1) Pago con Remesa Bancaria;
- 2) Pago a plazos;
- 3) Pago con carta de crédito para los clientes extranjeros.

En caso de que no se lleve a cabo el pago aunque sea sólo de una letra del importe - en el caso de que se haya acordado entre las partes el pago a plazos - se extinguirá el beneficio del plazo del comprador, debiendo éste proceder al pago inmediatamente del importe total.

El importe mínimo facturable equivale a 150,00 € (netos, I.V.A. excluido). Los pedidos que no alcancen el importe de 200,00 € (netos, incluido el transporte y excluido el I.V.A.) serán despachados taxativamente mediante pago contra reembolso mediante servicio de correo urgente, con consignación puerto franco, por cuenta y riesgo del remitente con cargo a su cuenta.

ENTREGA

El plazo de entrega se considera normalmente de 4 semanas, salvo indicación diversa de la empresa.

En todo caso, las posibles demoras en la entrega debidas a factores contingentes de producción no podrán dar lugar a demoras por parte del comprador en el pago de la mercancía suministrada, a no ser que hayan sido acordadas expresamente por escrito entre las partes, ni darán derecho a descuentos o a la disminución del precio de la lista.

DERECHO DE DESISTIMIENTO DE LA COMPRA

La normativa italiana que regula los contratos de venta entre actividades comerciales, en este caso, la de la vendedora y la del revendedor/distribuidor, no prevé la posibilidad de desistimiento del contrato de compraventa una vez que la mercancía haya sido entregada.

Rogamos, por tanto, a los clientes que:

- A) **comprueben atentamente las características técnicas, medidas, peso y precio del artículo** elegido de esta lista antes de efectuar el pedido;
- B) **lean atentamente la confirmación de pedido enviada por fax por la vendedora**, comparando los datos indicados en la misma con los del propio pedido, para que correspondan exactamente a lo que se desea comprar;
- C) comuniquen inmediatamente a la vendedora las diferencias detectadas y las posibles modificaciones que deben realizarse al pedido.

Una vez entregada la mercancía, la relación contractual se considerará concluida, por tanto, la **vendedora, a partir de este momento, no aceptará ninguna solicitud de devolución que derive de una compra errónea.**

DEVOLUCIÓN

La devolución se realizará Franco fábrica de Sedico cargado (**ex-works loaded**).

INTERESES

Los intereses, en caso de demora en el pago del precio, se calcularán automáticamente en base al Euribor 3 meses más 5 puntos porcentuales, devengados a partir de la fecha de vencimiento establecida en las condiciones de pago.

GARANTÍA

La garantía es de 24 meses desde la fecha de facturación y cubre los defectos que se pueden atribuir a los materiales o a la fabricación que se manifiesten durante el uso normal del equipo. Durante el periodo de garantía el usuario tiene que ponerse en contacto con el distribuidor para las señalizaciones o reclamaciones. La eventual sustitución de una pieza durante el periodo de garantía no prolonga la duración de la garantía más allá del límite inicial. Las piezas en garantía se envían por cuenta y riesgo del comprador.

La garantía no se reconoce en caso de instalación errónea, si se utiliza agua sucia o agresiva, en caso de presencia de cal y de utilización de agua dura, si la tensión y las frecuencias de alimentación son distintas de las que se especifican en la placa de características técnica, si se utiliza un gas contaminado o fuera de especificación en las unidades de gas. La garantía no se reconoce si el daño se produce fuera del aparato como, por ejemplo, sobretensiones de origen atmosférica.

La garantía no cubre eventuales daños de transporte.

La garantía no se reconoce en caso de mala utilización del equipo.

La garantía sobre los materiales no se reconoce si se utiliza un detergente distinto del que se recomienda de forma explícita.

Quedan excluidas de la garantía las partes de desgaste normal como: las juntas de estanqueidad, las bombillas y los cristales internos de las puertas. La garantía queda anulada si el mantenimiento lo realiza personal no autorizado o si se utilizan recambios no originales.

La garantía sólo es válida respecto al comprador original.

SEGURO CONTRA RIESGOS

Con arreglo al art. 1 del "D.P.R." (Decreto del Presidente de la República Italiana) 21/5/1988 n° 224.

En cumplimiento con lo establecido anteriormente, nuestro producto está asegurado contra los defectos de fabricación, errores de concepción o realización del proyecto, embalaje defectuoso o empaquetado y errores de instrucción para el uso a partir del 01.01.1989.

BORRADOR DE LA PÓLIZA EN CUMPLIMIENTO DE LAS OBLIGACIONES ESTABLECIDAS EN LA LEY

El seguro cubre al fabricante contra: defectos de fabricación, errores de concepción o realización del proyecto.

La indemnización deberá ser por daños (capital, intereses y gastos) ocasionados de manera involuntaria a terceros por el producto defectuoso tras la entrega del mismo.

La garantía se presta para los productos fabricados, confeccionados o importados en Italia, entregados en cualquier país y para los siniestros, cualquiera que sea el lugar en el que se produzcan, EE. UU. y Canadá excluidos.

DAÑOS AL PRODUCTO COMO CONSECUENCIA DEL TRANSPORTE

Cómo comportarse en caso de daños derivados del transporte:

- A) **DAÑOS EVIDENTES A LOS EMBALAJES Y A LA MERCANCÍA CONTENIDA EN LOS MISMOS**

El destinatario deberá rechazar la mercancía, en el momento de la entrega de la misma, indicando en el ALBARÁN DE ENVÍO del transportista la frase "**mercancía dañada**".

- B) **DAÑOS AL EMBALAJE**

Proceder a la comprobación y seguir el procedimiento descrito anteriormente (punto A). En el caso de que no se pueda realizar la oportuna comprobación en el momento de la entrega, deberá escribirse en los albaranes (de transporte y de entrega) la frase "**reserva de control**". El control del estado de la mercancía deberá realizarse en el plazo de tres días a partir de la entrega. Este es un derecho previsto en la ley. En caso de avería, parcial o total, deberá comunicarse mediante **carta certificada "A/R." (o fax)** al transportista y, en fotocopia, mediante fax a la vendedora, indicando si el daño es total o parcial.

- C) **AVERÍA NO RECONOCIBLE: DAÑOS OCULTOS**

En este caso, la ley italiana 450/85, art. 1698, prevé la admisión al reembolso siempre que el daño se denuncie nada más se tenga conocimiento del mismo mediante carta certificada "A/R." (o fax) al transportista, enviando una copia a la vendedora y, en todo caso, **dentro del plazo de ocho días a partir de la recepción.**

Si no se rechaza la mercancía en el momento de la entrega, la mercancía considerada dañada deberá enviarse, previo acuerdo con la vendedora, a nuestra fábrica de Sedico con EL MOTIVO "devolución por daños como consecuencia del transporte" y con MODALIDAD de ENTREGA "transporte en cuenta servicio", con todos los accesorios, sin excluir ninguno y con el mismo transportista de la entrega. A falta de lo indicado anteriormente, no se aceptarán reclamaciones efectuadas con retraso o incompletas. La mercancía se considerará entregada regularmente y aceptada sin reservas, liberando al transportista de sus obligaciones, en conformidad con las obligaciones del receptor.

Las mercancías que se nos señale mediante fax introducidas en los procedimientos descritos en los casos A + B + C, **se volverán a enviar a los clientes que así lo soliciten siempre y sólo en venta.**

La vendedora procederá a la emisión de la "**nota de crédito**" como compensación, parcial o total, de las mercancías dañadas sólo después de haber comprobado que se han respetado los procedimientos establecidos en la ley italiana 450/85 y después de haber recibido, en el propio almacén de Sedico, la mercancía objeto de la reclamación y haber comprobado, con el perito del transportista, la veracidad de la denuncia contenida en la carta certificada "A/R." (o fax) enviada por el cliente.



Giorik SpA
via Cavalieri di Vittorio Veneto, 14
32036 Sedico (BL) | ITALY

tel. +39.0437.807200 | fax +39.0437.807001
e-mail: info@giorik.com

www.giorik.com

Giorik US Corporation
400 Birnie Street, Suite D,
Greenville, SC 29611 | USA

tel. 1-833-446-7451
e-mail: info@gjorikus.com

www.gjorikus.com

